

Drywall Studs & Track

Industry standard nomenclature is used to identify MBA’s products. The Steel Framing Industry Association has established standard designation codes for drywall studs and track. In each case, the identification starts with the measurement of the width of the member, followed by a letter (S = stud and T = track) followed by the flange dimension. A hyphen is used to separate all of this from the thickness of the metal.

Member Depth:

(Example: 3-5/8" = 3.625" = **362** x 1/100 inches)

All member depths are taken in 1/100 inches. For all "T" sections member depth is the inside to inside dimension.

Flange Width:

(Example: 1-1/4" = 1.25" = **125** x 1/100 inches)

All flange widths are taken in 1/100 inches.



Style:

(Example: Stud or Joist Section = S)

Relevant alpha characters utilized by the designation system are:

S = Stud or Joist Sections

T = Track Sections

Material Thickness:

(Example: 0.018 in. = **18** mils; 1 mil = 1/1000 in.)

Material thickness is the minimum base metal thickness in mils. Minimum base metal thickness represents 95% of the design thickness.

Steel Thickness

Mils	Gauge	Thickness (in)	
		Design	Minimum ¹
18	25	0.0188	0.0179
27	22	0.0283	0.0269
30	20	0.0312	0.0296
33	20	0.0346	0.0329

¹ Minimum Thickness represents 95% of the design thickness and is the minimum acceptable thickness delivered to the job site based on Section A3.4 of the 1996 AISI Specification.

Design Stiffening Lip Length

Section	Flange Width	Design Stiffening Lip Length (in)
S125	1-1/4"	0.188

Drywall Stud Punchouts

Drywall studs are manufactured with punchouts to enable plumbing and wiring installation. The lowest punchout is centered 12" from the bottom and 24" or 48" o.c thereafter, with the final opening 12" minimum from the top. Care should be taken during installation to orient all studs in the same top-to-bottom direction.

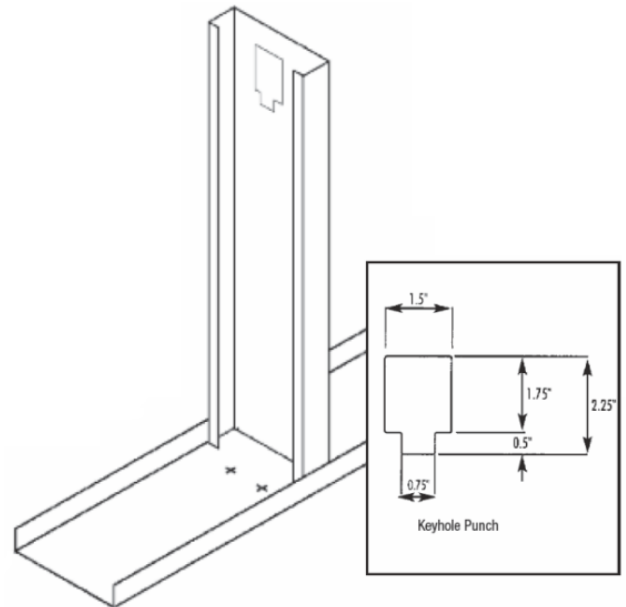

General Notes

1. Physical properties and load tables have been calculated in conformance with the 2001 NASPEC for the Design of Cold-Formed Steel Structural Members, including the 2004 Supplement, and the IBC 2006, unless noted otherwise.
2. Drywall framing members have a protective coating conforming to ASTM spec A 653/A 653M, G-40 min, or equivalent corrosion resistance.
3. Reference ASTM specification A 1003/A 1003 M table 1 for the universe of allowable coatings for light gauge steel framing.
4. Drywall framing members are marked with product information per the requirements of ASTM C 645 section 14.
5. All delivered material must be kept dry, preferably by being stored inside a building under a roof. If it is necessary to store material outside, it must be stacked off the ground, properly supported on a level platform, and fully protected from the weather. Reference ASTM C 754 section 8 and ASTM C 1007 section 4.
6. Drywall framing [nonstructural 25 gauge, 22 gauge and 20 gauge] is not permitted in load bearing (i.e. axial load greater than 200 lbs.) or exterior applications (i.e. transverse load greater than 10 PSF). Reference ASTM C 645 section 3.2.2.

LEED Green Building Credits

MR Credit 2: Construction Waste Management – MBA steel framing is 100% recyclable.

MR Credit 4: Recycled Content – MBA steel framing is formed from no less than 25.5% post-consumer and 6.8% pre-consumer recycled content.

MR Credit 5: Regional Materials – MBA has manufacturing facilities in multiple states.

Section Properties

Section Properties Table Notes

1. Web depth for track sections is equal to the nominal height plus 2 times design thickness plus the bend radius.
2. Hems on non-structural track sections are ignored.
3. Effective properties incorporate the strength increase from the cold work of forming as applicable per per NASPEC section A7.2.
4. Tabulated gross properties are based on the full, unreduced section away from punchouts.
5. Effective properties of all 'S' sections based on punched sections. Track sections are considered unpunched.
6. For deflection calculations, use the effective moment of inertia.

Non-Structural (S) Stud Section Properties

Section	Design Thickness (in)	Gross Properties						Effective Properties (33ksi)					Torsional						
		Area (in ²)	Weight (lb/ft)	I _x (in ⁴)	S _x (in ³)	R _x (in)	I _y (in ⁴)	R _y (in)	I _x (in ⁴)	S _x (in ³)	Ma (in-k)	V _{ag} (lb)	Vanet (lb)	J ^{x1000} (in ⁴)	C _w (in ⁶)	X _o (in)	m (in)	R _o (in)	β
162S125-18	0.0188	0.080	0.27	0.038	0.046	0.686	0.016	0.447	0.034	0.031	0.61	302	100	0.009	0.009	-1.029	0.594	1.315	0.388
162S125-27	0.0283	0.120	0.41	0.056	0.068	0.682	0.023	0.443	0.055	0.053	1.05	494	106	0.032	0.013	-1.017	0.587	1.302	0.390
162S125-30	0.0312	0.131	0.45	0.061	0.075	0.681	0.026	0.441	0.060	0.060	1.19	543	106	0.043	0.014	-1.014	0.585	1.298	0.390
162S125-33	0.0346	0.145	0.49	0.067	0.083	0.679	0.028	0.440	0.066	0.069	1.37	601	105	0.058	0.016	-1.010	0.583	1.294	0.391
250S125-18	0.0188	0.097	0.33	0.099	0.079	1.014	0.019	0.439	0.089	0.059	1.17	258	196	0.011	0.023	-0.904	0.543	1.427	0.599
250S125-27	0.0283	0.144	0.49	0.147	0.118	1.009	0.027	0.434	0.144	0.097	1.92	685	344	0.039	0.034	-0.893	0.536	1.416	0.602
250S125-30	0.0312	0.159	0.54	0.161	0.129	1.008	0.030	0.433	0.159	0.110	2.17	832	378	0.052	0.037	-0.889	0.534	1.412	0.603
250S125-33	0.0346	0.176	0.60	0.178	0.142	1.006	0.033	0.431	0.175	0.125	2.48	975	399	0.070	0.040	-0.885	0.532	1.408	0.605
350S125-18	0.0188	0.115	0.39	0.215	0.123	1.366	0.021	0.423	0.203	0.072	1.42	180	159	0.014	0.050	-0.797	0.495	1.637	0.763
350S125-27	0.0283	0.173	0.59	0.320	0.183	1.361	0.030	0.418	0.315	0.130	2.57	614	359	0.046	0.072	-0.787	0.489	1.627	0.766
350S125-30	0.0312	0.190	0.65	0.351	0.201	1.359	0.033	0.417	0.346	0.150	2.96	824	436	0.062	0.079	-0.784	0.487	1.624	0.767
350S125-33	0.0346	0.210	0.72	0.387	0.221	1.358	0.036	0.415	0.382	0.175	3.45	1024	487	0.084	0.087	-0.780	0.485	1.620	0.768
362S125-18	0.0188	0.118	0.40	0.234	0.129	1.409	0.021	0.421	0.221	0.075	1.48	173	163	0.014	0.054	-0.786	0.490	1.667	0.778
362S125-27	0.0283	0.176	0.60	0.347	0.192	1.404	0.031	0.416	0.342	0.135	2.67	592	370	0.047	0.079	-0.776	0.484	1.657	0.781
362S125-30	0.0312	0.194	0.66	0.381	0.210	1.402	0.033	0.415	0.376	0.156	3.08	794	449	0.063	0.086	-0.773	0.482	1.654	0.782
362S125-33	0.0346	0.215	0.73	0.421	0.232	1.400	0.037	0.413	0.415	0.182	3.59	1024	521	0.086	0.094	-0.769	0.480	1.650	0.783
400S125-18 ¹	0.0188	0.125	0.42	0.294	0.147	1.536	0.021	0.414	0.281	0.083	1.64	156	156	0.015	0.068	-0.754	0.475	1.760	0.816
400S125-27	0.0283	0.187	0.64	0.438	0.219	1.531	0.031	0.410	0.431	0.151	2.97	533	398	0.050	0.098	-0.744	0.469	1.751	0.819
400S125-30	0.0312	0.206	0.70	0.481	0.240	1.529	0.034	0.408	0.474	0.174	3.44	715	484	0.067	0.107	-0.741	0.467	1.748	0.820
400S125-33	0.0346	0.228	0.77	0.531	0.265	1.527	0.038	0.407	0.524	0.203	4.01	976	595	0.091	0.118	-0.738	0.465	1.744	0.821
550S125-18 ¹	0.0188	0.153	0.52	0.630	0.229	2.029	0.023	0.390	0.898	0.246	4.86	382	382	0.018	0.140	-0.651	0.423	2.166	0.910
550S125-27	0.0283	0.229	0.78	0.938	0.341	2.023	0.034	0.385	0.996	0.286	5.65	512	512	0.061	0.205	-0.641	0.417	2.157	0.912
550S125-30	0.0312	0.252	0.86	1.031	0.375	2.021	0.037	0.384	0.996	0.286	5.65	512	512	0.082	0.224	-0.639	0.415	2.154	0.912
550S125-33	0.0346	0.279	0.95	1.139	0.414	2.019	0.041	0.382	1.111	0.335	6.62	699	699	0.112	0.246	-0.635	0.413	2.151	0.913
600S125-18 ¹	0.0188	0.162	0.55	0.778	0.259	2.189	0.024	0.382	0.019	0.172	-0.623	0.408	2.308	0.019	0.172	-0.623	0.408	2.308	0.927
600S125-27 ¹	0.0283	0.243	0.83	1.160	0.387	2.183	0.035	0.377	1.097	0.271	5.35	349	349	0.065	0.251	-0.614	0.402	2.299	0.929
600S125-30	0.0312	0.268	0.91	1.275	0.425	2.181	0.038	0.376	1.218	0.315	6.22	468	468	0.087	0.274	-0.611	0.401	2.296	0.929
600S125-33	0.0346	0.297	1.01	1.409	0.470	2.179	0.042	0.374	1.361	0.369	7.30	638	638	0.118	0.300	-0.608	0.399	2.293	0.930

¹ Web-height to thickness ratio exceeds 200. Web Stiffeners are required at all support points and concentrated loads.

Section Properties

Section Properties Table Notes

1. Web depth for track sections is equal to the nominal height plus 2 times design thickness plus the bend radius.
2. Hems on non-structural track sections are ignored.
3. Effective properties incorporate the strength increase from the cold work of forming as applicable per per NASPEC section A7.2.
4. Tabulated gross properties are based on the full, unreduced section away from punchouts.
5. Effective properties of all 'S' sections based on punched sections. Track sections are considered unpunched.
6. For deflection calculations, use the effective moment of inertia.

Non-Structural (T) Track Section Properties

Section	Design Thickness (in)	Gross Properties							Effective Properties (33ksi)				Torsional					
		Area (in ²)	Weight (lb/ft)	I _x (in ⁴)	S _x (in ³)	R _x (in)	I _y (in ⁴)	R _y (in)	I _x (in ⁴)	S _x (in ³)	I _{Ma} (in-k)	V _{ag} (lb)	J ^{x1000} (in ⁴)	C _w (in ⁶)	X _o (in)	m (in)	R _o (in)	β
162T125-18	0.0188	0.077	0.26	0.041	0.047	0.733	0.013	0.411	0.030	0.025	0.50	302	0.009	0.007	-0.878	0.503	1.215	0.478
162T125-27	0.0283	0.117	0.40	0.063	0.072	0.735	0.020	0.410	0.050	0.044	0.87	541	0.031	0.010	-0.872	0.501	1.211	0.482
162T125-30	0.0312	0.129	0.44	0.070	0.079	0.735	0.022	0.409	0.057	0.050	1.00	597	0.042	0.012	-0.870	0.500	1.210	0.483
162T125-33	0.0346	0.143	0.49	0.077	0.087	0.736	0.024	0.408	0.066	0.058	1.15	663	0.057	0.013	-0.868	0.499	1.209	0.484
250T125-18	0.0188	0.094	0.32	0.103	0.079	1.051	0.015	0.400	0.078	0.045	0.90	249	0.011	0.018	-0.769	0.460	1.362	0.681
250T125-27	0.0283	0.141	0.48	0.157	0.119	1.053	0.022	0.398	0.129	0.079	1.56	685	0.038	0.027	-0.763	0.457	1.360	0.685
250T125-30	0.0312	0.156	0.53	0.173	0.131	1.053	0.025	0.397	0.145	0.090	1.77	832	0.051	0.030	-0.762	0.456	1.359	0.686
250T125-33	0.0346	0.173	0.59	0.192	0.145	1.054	0.027	0.397	0.166	0.103	2.03	1024	0.069	0.033	-0.760	0.456	1.358	0.687
250T200-33	0.0346	0.225	0.76	0.280	0.212	1.117	0.097	0.658	0.203	0.112	2.22	1024	0.090	0.118	-1.418	0.813	1.921	0.455
350T125-18	0.0188	0.113	0.38	0.219	0.121	1.394	0.016	0.383	0.174	0.063	1.25	175	0.013	0.038	-0.675	0.418	1.595	0.821
350T125-27	0.0283	0.170	0.58	0.331	0.182	1.396	0.025	0.381	0.277	0.128	2.53	590	0.045	0.057	-0.670	0.416	1.595	0.823
350T125-30	0.0312	0.187	0.64	0.365	0.200	1.396	0.027	0.380	0.312	0.145	2.86	790	0.061	0.063	-0.669	0.415	1.594	0.824
350T125-33	0.0346	0.207	0.71	0.405	0.222	1.397	0.030	0.379	0.354	0.165	3.27	1024	0.083	0.070	-0.668	0.414	1.594	0.824
350T200-33	0.0346	0.259	0.88	0.574	0.315	1.487	0.108	0.647	0.428	0.181	3.57	1024	0.103	0.249	-1.285	0.761	2.069	0.614
362T125-18	0.0188	0.115	0.39	0.237	0.126	1.435	0.017	0.380	0.189	0.065	1.29	169	0.014	0.042	-0.665	0.413	1.627	0.833
362T125-27	0.0283	0.173	0.59	0.358	0.191	1.438	0.025	0.378	0.301	0.135	2.66	569	0.046	0.062	-0.661	0.411	1.627	0.835
362T125-30	0.0312	0.191	0.65	0.395	0.210	1.438	0.027	0.378	0.339	0.152	3.01	762	0.062	0.068	-0.659	0.410	1.626	0.836
362T125-33	0.0346	0.212	0.72	0.438	0.232	1.438	0.030	0.377	0.384	0.174	3.44	1024	0.085	0.076	-0.658	0.409	1.626	0.836
362T200-33	0.0346	0.264	0.90	0.619	0.328	1.532	0.110	0.645	0.464	0.190	3.76	1024	0.105	0.269	-1.270	0.754	2.092	0.631
400T125-18 ¹	0.0188	0.122	0.41	0.297	0.144	1.560	0.017	0.374	0.241	0.072	1.42	153	0.014	0.052	-0.637	0.400	1.726	0.864
400T125-27	0.0283	0.184	0.63	0.449	0.217	1.562	0.025	0.372	0.380	0.156	3.08	515	0.049	0.078	-0.633	0.398	1.726	0.866
400T125-30	0.0312	0.203	0.69	0.495	0.239	1.562	0.028	0.371	0.427	0.176	3.49	689	0.066	0.085	-0.632	0.397	1.726	0.866
400T125-33	0.0346	0.225	0.76	0.549	0.265	1.563	0.031	0.371	0.484	0.201	3.97	940	0.090	0.095	-0.630	0.396	1.725	0.867
400T200-33	0.0346	0.277	0.94	0.768	0.371	1.666	0.113	0.639	0.581	0.220	4.34	940	0.110	0.336	-1.229	0.737	2.166	0.678
550T125-27	0.0283	0.226	0.77	0.948	0.336	2.046	0.027	0.348	0.786	0.192	3.79	372	0.060	0.160	-0.543	0.352	2.145	0.936
550T125-30	0.0312	0.250	0.85	1.045	0.370	2.046	0.030	0.347	0.897	0.226	4.47	499	0.081	0.176	-0.542	0.351	2.145	0.936
550T125-33	0.0346	0.277	0.94	1.159	0.410	2.046	0.033	0.346	1.029	0.270	5.33	680	0.110	0.195	-0.541	0.350	2.145	0.936
550T200-33	0.0346	0.329	1.12	1.567	0.555	2.184	0.123	0.613	1.246	0.307	6.06	680	0.131	0.694	-1.088	0.674	2.516	0.813
600T125-27 ¹	0.0283	0.241	0.82	1.168	0.381	2.204	0.028	0.340	0.958	0.210	4.16	341	0.064	0.196	-0.519	0.339	2.290	0.949
600T125-30	0.0312	0.265	0.90	1.288	0.419	2.204	0.031	0.340	1.095	0.249	4.92	456	0.086	0.215	-0.518	0.338	2.289	0.949
600T125-33	0.0346	0.294	1.00	1.428	0.465	2.204	0.034	0.339	1.258	0.297	5.87	622	0.117	0.238	-0.516	0.337	2.289	0.949
600T200-33	0.0346	0.346	1.18	1.913	0.622	2.352	0.126	0.604	1.542	0.333	6.59	622	0.138	0.847	-1.048	0.655	2.645	0.843

¹ Web-height to thickness ratio exceeds 200. Web Stiffeners are required at all support points and concentrated loads.

Limiting Wall Heights

Interior Non-Structural Composite Table Notes

1. Based on tests conducted with single layer ½ in. gypsum board attached with screws spaced 12 in. o.c. to framing members.
2. Maximum stud heights are also applicable to walls sheathed with greater than ½ in. thick and multiple layers of gypsum board.
3. Runner flanges need not be fastened to studs except as required by ASTM C 754 paragraph 5.3.2.1.
4. 362S125 member is based on 350S125 test data. For both 362S125 and 350S125 members use values listed for 362S125.

Interior Non-Structural Composite

Section	Spacing (in) o.c.	5 psf			7.5 psf			10 psf		
		L/120	L/240	L/360	L/120	L/240	L/360	L/120	L/240	L/360
162S125-18	12	11' 2"	8' 10"		9' 9"			8' 10"		
162S125-18	16	10' 7"	8' 4"		8' 10"			8' 4"		
162S125-18	24	9' 9"	7' 11"		8' 0"					
162S125-30	12	12' 5"	9' 11"		10' 10"			9' 11"		
162S125-30	16	11' 6"	9' 2"		10' 1"			9' 2"		
162S125-30	24	10' 5"	8' 3"		9' 2"			8' 3"		
162S125-33	12	13' 0"	10' 4"	9' 0"	11' 4"	9' 0"		10' 4"		
162S125-33	16	12' 1"	9' 8"	8' 5"	10' 7"	8' 5"		9' 8"		
162S125-33	24	11' 0"	8' 9"	7' 8"	9' 7"	7' 8"		8' 9"		
250S125-18	12	15' 1"	11' 11"	10' 5"	12' 4"	10' 5"	9' 1"	10' 9"	9' 6"	
250S125-18	16	13' 3"	11' 3"	9' 10"	10' 10"	9' 10"	8' 7"	9' 5"	8' 11"	
250S125-18	24	11' 10"	10' 7"	9' 3"	9' 8"	9' 3"	8' 1"	8' 5"	8' 5"	
250S125-30	12	16' 8"	13' 2"	11' 6"	14' 7"	11' 6"	10' 0"	13' 2"	10' 5"	9' 1"
250S125-30	16	15' 4"	12' 1"	10' 6"	13' 4"	10' 6"	9' 2"	12' 1"	9' 6"	8' 4"
250S125-30	24	13' 9"	10' 9"	9' 4"	11' 11"	9' 4"	8' 1"	10' 9"	8' 6"	7' 4"
250S125-33	12	17' 9"	13' 11"	12' 1"	15' 6"	12' 1"	10' 6"	13' 11"	10' 11"	9' 5"
250S125-33	16	16' 5"	12' 10"	11' 2"	14' 4"	11' 2"	9' 8"	12' 10"	10' 0"	8' 8"
250S125-33	24	14' 10"	11' 7"	10' 0"	13' 0"	10' 0"	8' 7"	11' 7"	8' 11"	7' 8"
362S125-18	12	17' 8"	15' 4"	13' 3"	14' 3"	13' 3"	11' 7"	12' 5"	12' 0"	10' 5"
362S125-18	16	15' 4"	14' 4"	12' 4"	12' 5"	12' 5"	10' 10"	10' 9"	10' 9"	9' 9"
362S125-18	24	13' 9"	13' 5"	11' 7"	11' 0"	11' 0"	10' 1"	9' 5"	9' 5"	9' 1"
362S125-30	12	21' 8"	17' 1"	14' 10"	18' 1"	14' 10"	12' 10"	17' 1"	13' 5"	11' 8"
362S125-30	16	19' 11"	15' 8"	13' 7"	17' 5"	13' 7"	11' 9"	15' 8"	12' 3"	10' 7"
362S125-30	24	17' 9"	14' 0"	12' 0"	15' 6"	12' 0"	10' 5"	14' 0"	10' 10"	9' 4"
362S125-33	12	22' 6"	17' 10"	15' 6"	19' 8"	15' 6"	13' 7"	17' 10"	14' 1"	12' 4"
362S125-33	16	20' 8"	16' 5"	14' 3"	18' 1"	14' 3"	12' 6"	16' 5"	12' 11"	11' 4"
362S125-33	24	18' 6"	14' 9"	12' 9"	16' 2"	12' 9"	11' 2"	14' 9"	11' 7"	10' 1"
400S125-18	12	19' 6"	16' 5"	14' 4"	15' 9"	14' 4"	12' 6"	13' 8"	13' 0"	11' 4"
400S125-18	16	17' 2"	15' 4"	13' 4"	13' 10"	13' 4"	11' 8"	11' 11"	11' 11"	10' 6"
400S125-18	24	15' 1"	14' 2"	12' 4"	12' 1"	12' 1"	10' 9"	10' 5"	10' 5"	9' 9"
400S125-30	12	24' 0"	19' 0"	16' 6"	20' 11"	16' 6"	14' 4"	19' 0"	14' 11"	12' 11"
400S125-30	16	22' 0"	17' 6"	15' 2"	19' 3"	15' 2"	13' 1"	17' 6"	13' 8"	11' 10"
400S125-30	24	19' 8"	15' 7"	13' 5"	17' 1"	13' 5"	11' 7"	14' 9"	12' 1"	10' 5"
400S125-33	12	25' 1"	19' 11"	17' 4"	21' 11"	17' 4"	15' 0"	19' 11"	15' 8"	13' 7"
400S125-33	16	23' 1"	18' 4"	15' 11"	20' 2"	15' 11"	13' 9"	18' 4"	14' 5"	12' 6"
400S125-33	24	20' 9"	16' 5"	14' 3"	18' 1"	14' 3"	12' 4"	16' 5"	12' 10"	11' 2"
600S125-18	12	22' 10"	22' 1"	19' 4"	18' 7"	18' 7"	16' 9"	16' 2"	16' 2"	15' 0"
600S125-18	16	19' 9"	19' 9"	17' 11"	16' 2"	16' 2"	15' 7"	14' 0"	14' 0"	13' 10"
600S125-18	24	16' 9"	16' 9"	16' 9"	13' 5"	13' 5"	13' 5"	11' 5"	11' 5"	11' 5"
600S125-30	12	32' 1"	25' 6"	22' 3"	28' 0"	22' 3"	19' 5"	24' 7"	20' 3"	17' 6"
600S125-30	16	29' 2"	23' 2"	20' 3"	24' 9"	20' 3"	17' 8"	21' 5"	18' 4"	15' 10"
600S125-30	24	25' 1"	20' 3"	17' 8"	20' 6"	17' 8"	15' 5"	17' 9"	16' 0"	13' 8"
600S125-33	12	33' 9"	26' 9"	23' 5"	29' 6"	23' 5"	20' 6"	26' 9"	21' 3"	18' 7"
600S125-33	16	30' 10"	24' 6"	21' 4"	27' 0"	21' 4"	18' 9"	24' 6"	19' 5"	17' 0"
600S125-33	24	27' 2"	21' 7"	18' 10"	23' 10"	18' 10"	16' 7"	19' 1"	17' 3"	15' 0"

Notes:

1. Tested in conformance with ICC-ES AC86-95.
2. Data in accordance with ASTM C754-04, as adopted by 2006 and 2009 IBC.