

# MBA

METAL FRAMING





**Editor's Note: PDF users click on section title or page number to see that specific section**

i.	<u>Locations, Certifications, and Compliance</u>	<u>4-6</u>
ii.	<u>Product Catalog Introduction</u>	<u>7-8</u>
iii.	<u>General Product Information</u>	<u>9-10</u>
iv.	<u>ProSTUD &amp; ProTRAK</u>	<u>11-31</u>
v.	<u>UL Fire Testing</u>	<u>32-34</u>
vi.	<u>Structural Studs &amp; Track</u>	<u>35-71</u>
vii.	<u>Jamb Studs</u>	<u>72-73</u>
viii.	<u>Jamb and Header System</u>	<u>74-88</u>
ix.	<u>Furring Channel</u>	<u>89-90</u>
x.	<u>U-Channel</u>	<u>91-92</u>
xi.	<u>Z-Furring</u>	<u>93</u>
xii.	<u>Angle</u>	<u>94</u>
xiii.	<u>Flat Strap</u>	<u>95</u>
xiv.	<u>Resilient Channel</u>	<u>96-99</u>
xv.	<u>CRC Clip</u>	<u>100</u>
xvi.	<u>Web Stiffener</u>	<u>101</u>
xvii.	<u>Slotted Track</u>	<u>102</u>
xviii.	<u>Shaftwall System</u>	<u>103-104</u>
xix.	<u>Area Separation</u>	<u>105</u>

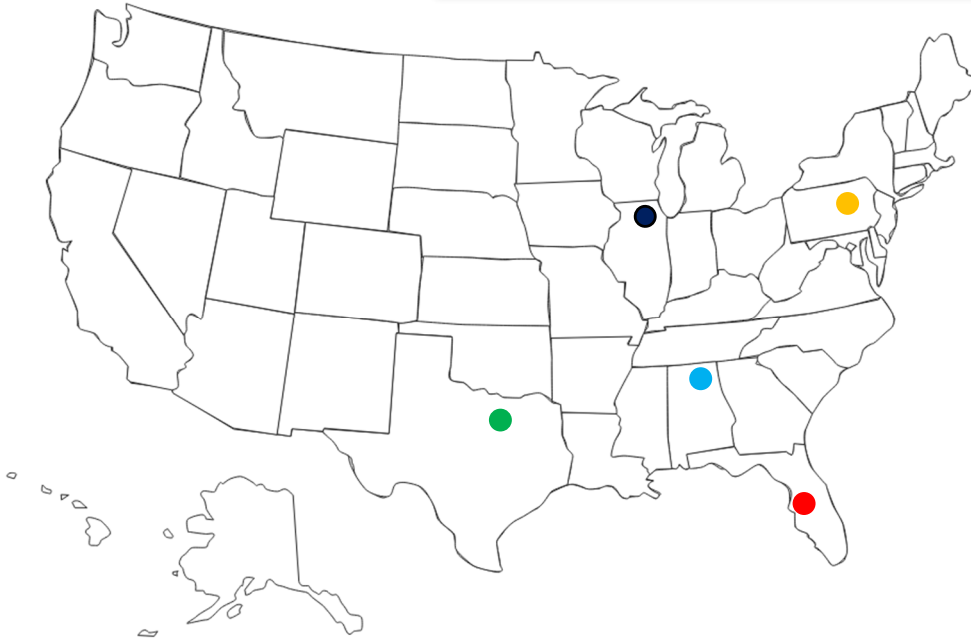

- Libertyville, IL:  
2200 Tempel Dr.60048
- Frackville, PA:  
100 Firemans Rd.17931
- Dallas, TX:  
10880 Bekay St.75238
- Rainbow City, AL: 1217  
West Grand Ave.35906
- Plant City, FL:  
3007 Central Dr.33566

## Protective Coating Standards

- ASTM C 645 Standard Specification for Nonstructural Steel Framing Members
- ASTM C 754 Standard Specification for Installation of Steel Framing Members to Receive Screw-Attached Gypsum Panel Products
- ASTM A 463/463M Standard Specification for Steel Sheet, Aluminum-Coated, by the Hot-Dip Process
- ASTM A 653 Standard Specification for Steel Sheet, Zinc-Coated (Galvanized) or Zinc-Iron Alloy-Coated (Galvannealed) by the Hot-Dip Process
- ASTM A 792/792M Standard Specification for Steel Sheet, 55 % Aluminum-Zinc Alloy-Coated by the Hot-Dip Process
- ASTM A 875/875M Standard Specification for Steel Sheet, Zinc-5% Aluminum Alloy-Coated by the Hot-Dip Process
- ASTM A924/A924M Standard Specification for General Requirements for Steel Sheet, Metallic-Coated by the Hot-Dip Process
- ASTM A1003/A1003M Standard Specification for Steel Sheet, Carbon, Metallic- and Nonmetallic-Coated for Cold-Formed Framing Members
- ASTM A1011/A1011M Standard Specification for Steel, Sheet and Strip, Hot-Rolled, Carbon, Structural, High-Strength Low-Alloy, High-Strength Low-Alloy with Improved Formability, and Ultra-High Strength

## SFIA Compliance

MBA structural framing comply with the SFIA Code Compliance Program.MBA is a member of SFIA.Check the updated list of Certified Production Facilities at Intertek’s website at [www.intertek.com](http://www.intertek.com)



## Website Link

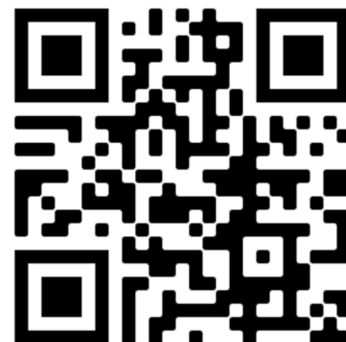

## Nonstructural Framing Standards

**AISI S100** North American Specification for the Design of Cold-Formed Steel Structural Members

**AISI S220** North American Standard for Cold-Formed Steel Framing– Nonstructural Members

**ASTM C 645** Standard Specification for Nonstructural Steel Framing Members

**ASTM C 754** Standard Specification for Installation of Steel Framing Members to Receive Screw-Attached Gypsum Panel Products

MBA has prepared this catalog with the utmost attention to detail for accuracy and conformance to standards. We reserve the right to modify or change this information without notice. We intend this information to be accurate, informative, and helpful when choosing our products. However, this information is only a guide and is not intended to replace the design, drawings, specifications, and decisions of a professional architect or engineer. MBA and its affiliates shall not be responsible for damages, directly or indirectly sustained, nor for loss caused by application of our products for anything other than their intended uses. Our liability is limited to replacement of defective products.

## Structural Framing Standards

**AISI S100** North American Specification for the Design of Cold-Formed Steel Structural Members

**AISI S240** North American Standard for Cold-Formed Steel Structural Framing

**ASTM C 955** Standard Specification for Cold-Formed Steel Structural Framing Members

**ASTM C 1007** Standard Specification for Installation of Load Bearing (Transverse and Axial) Steel Studs and Related Accessories

**ASTM A1008** Standard Specification for Steel, Sheet, Cold-Rolled, Carbon, Structural, High-Strength

Low-Alloy, High-Strength Low-Alloy with Improved Formability, Required Hardness,

Solution Hardened, and Bake Hardenable

**ASTM A1003/A1003M** Standard Specification for Steel Sheet, Carbon, Metallic- and Nonmetallic-Coated for Cold-Formed Framing Members



**MasterSpec**<sup>®</sup>  
a product of The American Institute of Architects

**SFIA**   
STEEL FRAMING INDUSTRY ASSOCIATION



**ARCAT**<sup>®</sup>

**AWCI**  
ASSOCIATION OF THE  
WALL AND CEILING  
INDUSTRY

Regarding: LEED® 2.2 Credits for Cold-Formed Steel Framing  
Credit MR 2.1/2.2 – Construction Waste Management  
Credit MR 4.1/4.2 – Recycled Content Credit Intent  
Credit MR 5.1/5.2 – Regional Materials

MBA Building Supplies manufactures light gauge metal framing products for use in both non-structural and load bearing applications. Steel framing is universally regarded for its recycled content composition, reclamation rate, and many other energy saving and environmental quality improving attributes. MBA supports the increasing demand for sustainable green buildings and recognizes the importance of steel framing towards reaching higher standards in environmentally and socially responsible construction.

“Steel is truly the most recycled material.”

Steel Recycling Institute (<http://www.recycle-steel.org/PDFs/leed/LEEDMAR09.pdf>)

### **Credit MR 2.1/2.2 – Construction Waste Management**

MBA metal framing products are 100% recyclable. Credits are awarded based on recycling and salvage rates of construction and demolition materials. Retain waste hauling certificates for documentation of recycling rates. Additionally, MBA metal framing can be cut to exact standards during the manufacturing process, significantly limiting total construction waste.

### **Credit MR 4.1/4.2 – Recycled Content Credit Intent**

The steel used by MBA in the manufacturing of light gauge metal framing is produced in one of two furnace types:

Basic Oxygen Furnace (BOF) or Electric Arc Furnace (EAF). Each furnace type uses a different production method, resulting in different levels of recycled content. Individual manufacturer recycled content statistics are not applicable because of the open loop recycling capability that steel and iron industries enjoy, with available scrap typically going to the closest melting furnace.

The Steel Recycling Institute has set the industry standard recycled content levels for steel originating in the BOF and EAF processes. MBA metal framing products originate from an indeterminable mix of steel from these two furnace types.

Basic Oxygen Furnace (BOF) Electric Arc Furnace (EAF)

Total Recycled Content 32.7% Total Recycled Content 93.3%

Post-Consumer Recycled Content 25.5% Post-Consumer Recycled Content 56.9%

Post-Industrial Recycled Content 6.8% Post-Industrial Recycled Content 31.4%

### **Credit MR 5.1/5.2 – Regional Materials**

The light gauge metal framing products provided by MBA for project sites are manufactured in multiple facilities throughout the United States. To qualify for this credit, MBA's facilities must be within 500 miles of the project site.

Additionally, the extraction point of the steel provided for the job site must also be within a 500-mile radius of the sourced location.

MBA is proud to support the construction of sustainable green buildings.

Light gauge steel framing is often regarded as a commodity purchase. Buyers assume that all producers manufacture their products to the same standards, so the products all have to be the same. We know better.

At MBA, we are squarely focused on manufacturing studs, joists, tracks, channels, and other accessories at or above industry design thickness. We meet or exceed all other industry standards, including ASTM, AISI, and IBC. The way we look at it, assured performance of the structure you build begins with the assured quality of the materials that go into it. That's why we simply won't compromise our product quality...ever.

We also regard service as an integral part of our product offering to customers. So, it should surprise no one that our service is second to none. MBA operates multiple manufacturing facilities, strategically located to serve your markets. We package and load materials to enhance jobsite use, and we deliver it as you ordered, where you needed it, and on time.

It is this dedication to product quality and customer service that has kept MBA among the foremost producers of light gauge steel framing since 1986. We are proud to have you as our customer.

## Standard Punch Patterns

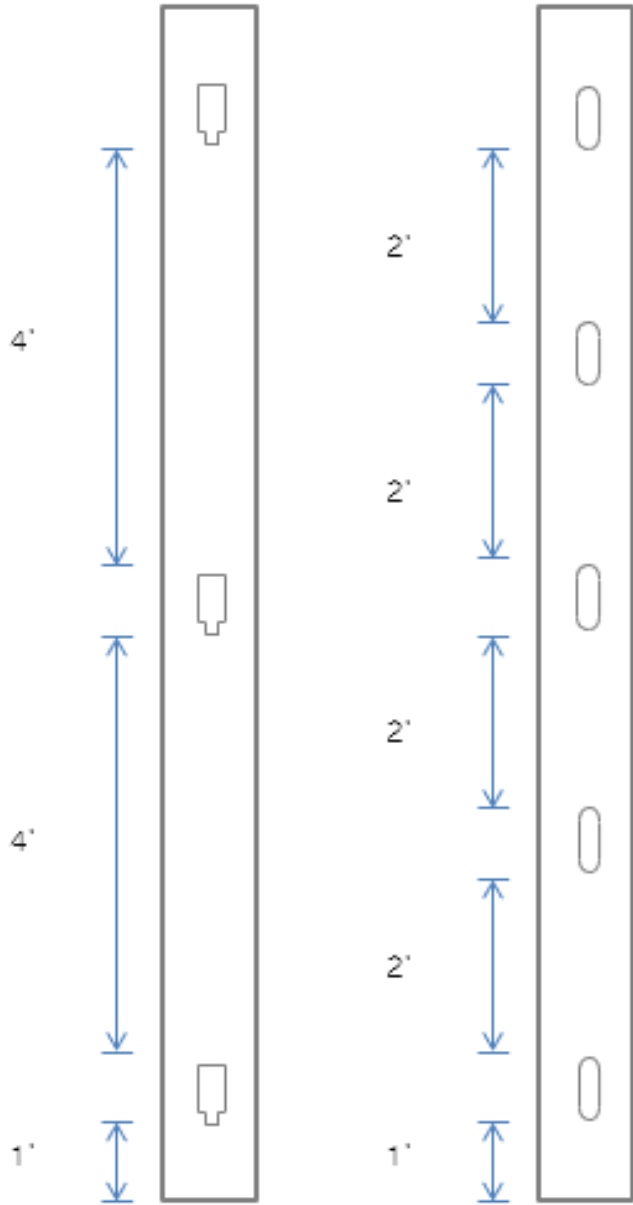

**Drywall  
Punch  
Pattern**

**Structural  
Punch  
Pattern**

## Drywall Knockouts

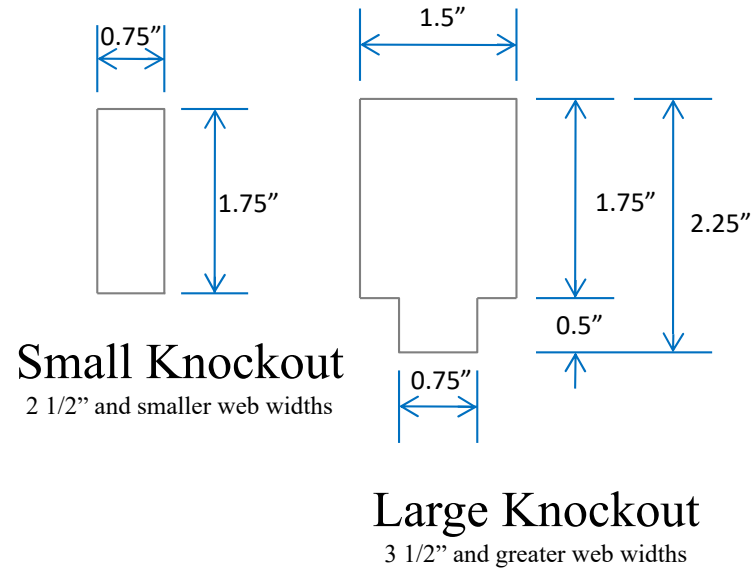

**Small Knockout**  
2 1/2" and smaller web widths

**Large Knockout**  
3 1/2" and greater web widths

## Structural Knockouts

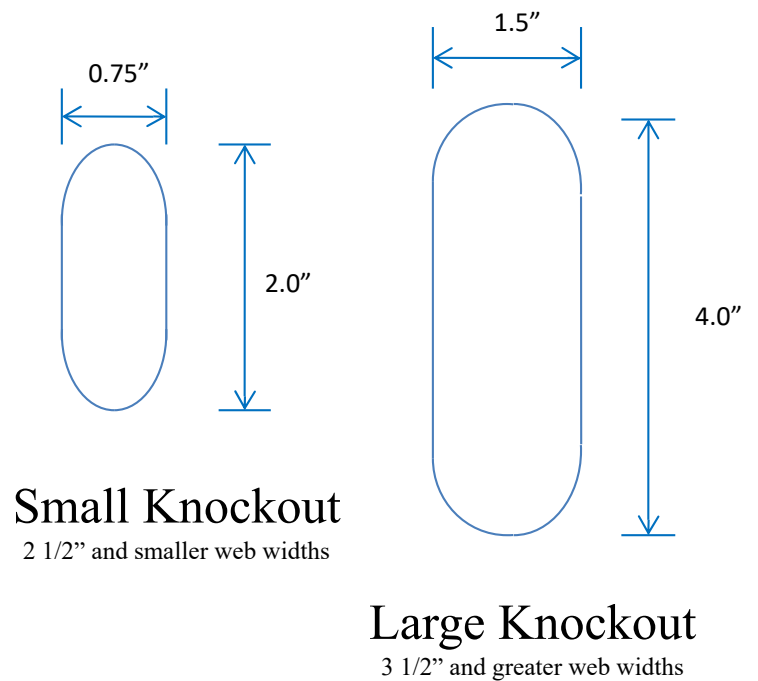

**Small Knockout**  
2 1/2" and smaller web widths

**Large Knockout**  
3 1/2" and greater web widths

Note : Special punch patterns available upon request

## Stiffening Lip Length

Section	Flange Width	Design Stiffening Lip Strength (in)
S125	1-1/4"	0.188
S137	1-3/8"	0.375
S162	1-5/8"	0.500
S200	2"	0.625
S250	2-1/2"	0.625
S300	3"	0.625
S350	3-1/2"	1.000

## Thickness Table

Designation Thickness Mils	Minimum Thickness (in)	Design Thickness (in)	Design Inside Corner Radii <sup>2</sup> (in)	Reference Gauge No.	Color
15	0.0150	0.0158	N/A	25 Gauge Eq-Pro	Dark Grey
18	0.0179	0.0188	0.0844	20 Gauge	No Color
30	0.0296	0.0312	0.0782	20 Gauge-Drywall	Pink
33	0.0329	0.0346	0.0765	20 Gauge-Pro33	White
33	0.0329	0.0346	0.0765	20 Gauge-Structural	White
43	0.0428	0.0451	0.0712	18 Gauge-Structural	Yellow
54	0.0538	0.0566	0.0849	16 Gauge-Structural	Green
68	0.0677	0.0713	0.1070	14 Gauge-Structural	Orange
97	0.0966	0.1017	0.1526	12 Gauge-Structural	Red
118	0.1180	0.1242	0.1863	10 Gauge-Structural	Blue

<sup>1</sup> Minimum Thickness represents 95% of the design thickness and is the minimum acceptable thickness delivered to the jobsite based on section B7.1 of the AISI S100-16/S1-18.

<sup>2</sup> The tables in this catalog are calculated based on inside corner radii listed in this table.

- Where AISI S100-16/S2-20 is referenced, it is the "North American Specification for the Design of Cold-Formed Steel Structural Members"; 2016 Edition, Supplement 2-20, with US provisions.
- The strength increase from cold work of forming has been incorporated for flexural strength per Section A3.3.2 of AISI S100-16/S2-20.
- The effective moment of inertia for deflection is calculated at a stress which results in a section modulus such that the stress times the section modulus at that stress is equal to the allowable moment. AISI S100-16/S2-20 Specification Procedure 1 for serviceability determination has been used. Increases in the effective moment of Inertia (I<sub>xe</sub>) may be possible at lower stress levels. Any modified values would be required to be calculated by a qualified engineer.
- Various sections may be manufactured with yield points of 33 or 50 ksi. The yield point used for calculations are listed in the tables.
- For sections available in both 33 and 50 ksi, the specifier must be clearly indicating which yield point is required. For example: 362S162-68 (50 ksi).
- When provided, factory punchouts will be located along the centerline of the webs of the members and will have a minimum center-to-center spacing of 24 inches. Punchouts for members greater than 2.5 inches deep are a maximum of 1.5 inches wide x 4 inches long.

Members with depths 2.5 inches and smaller are maximum of 3/4 inches wide x 4 inches long.

Complies with the 2021 International Building Code and AISI S100-16/S2-20

## Definitions of Structural Property Symbols

### Gross Properties

- I<sub>x</sub>: Moment of inertia of gross section about the X-X axis (strong axis).
- S<sub>x</sub>: Section modulus about the X-X axis (strong axis).
- R<sub>x</sub>: Radius of gyration of the gross section about the X-X axis.
- I<sub>y</sub>: Moment of inertia of gross section about the Y-Y axis (weak axis).
- R<sub>y</sub>: Radius of gyration of the gross section about the Y-Y axis.

### Effective Properties

- I<sub>xe</sub>: Effective moment of inertia about the X-axis.
- S<sub>xe</sub>: Effective section modulus about the X-X axis (strong axis) stress= F<sub>y</sub>.
- M<sub>a</sub>: Allowable Bending Moment - Based on the effective section modulus and the allowable stress including the strength increase from the cold-work of forming (Section A3.3.2) where applicable.
- M<sub>ad</sub>: Allowable Bending Moment - Based on Distortional Buckling Strength calculated per Sections F4, F4.1 of AISI S100-16/S2-20.
- V<sub>ag</sub>: Allowable strong axis shear away from punchout, calculated in accordance with Section G2 of AISI S100-16/S2-20.
- V<sub>anet</sub>: Allowable strong axis shear at punchout, calculated in accordance with Section G3 of AISI S100-16.

### Torsional and Other Properties

- J: St. Venant Torsional Constant.
- C<sub>w</sub>: Torsional warping constant.
- m: Distance from shear center to mid-plane of web.
- X<sub>o</sub>: Distance from the shear center to the centroid along the principal X-axis.
- R<sub>o</sub>: Polar radius of gyration about the centroidal principal axis.
- b:  $1-(X_o/R_o)^2$
- L<sub>u</sub>: The longest weak axis (L<sub>y</sub>) and torsional (L<sub>t</sub>) unbraced length at which lateral torsional buckling is restrained in accordance with Section F2.1 of AISI S100-16/S2-20.

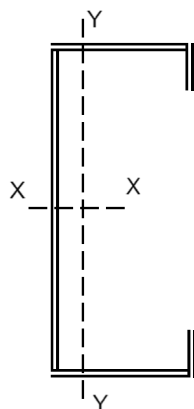

Complies with the 2021 International Building Code and AISI S100-16/S2-20

## Equivalent (EQ) Drywall Stud

Gauge equivalent drywall framing must meet the minimum performance requirements of conventional drywall framing as defined by the Steel Framing Industry Association (SFIA). The industry's "EQ" product of choice, ProSTUD,<sup>®</sup> employs roll-forming and steel-making technology, exceeding the performance of conventional drywall framing for allowable moment and screw connection strength. When comparing drywall framing systems, it is important to keep in mind Life Safety, System Performance and Connections. The ProSTUD Drywall Framing System provides peace of mind for all three important functions by providing the right selection of products and product data for every application.

### Life Safety

Life Safety is the primary concern and duty of all construction and design professionals. For interior drywall framing members, bending strength is the criteria most important to the strength of a wall or ceiling. AISI defines bending or flexural strength by Allowable Moment. The corresponding chart compares the bending strength of ProSTUD and conventional drywall studs.

### System Performance

Given ProSTUD's strength and versatility, it's important to know the performance of the ProSTUD member under your project's specific criteria. This catalog will provide guidance in a variety of assemblies and loading criteria, based on current building codes. Additional data is available at [clarkdietrich.com](http://clarkdietrich.com).

### Connections

In addition to sufficient member strength, it's important to know how connections will perform. Connections can be critical to the capacity and safety of an assembly, but they are also important for the attachment of cabinets, shelving, handrails, and other accessories to steel framing. The tables below compare the screw performance of ProSTUD to conventional drywall framing. This performance relationship to conventional studs can be applied to a variety of fasteners and connections.

## Comparison of ProSTUD Drywall Framing to Conventional Drywall Framing

### ProSTUD Drywall Framing

ProSTUD 25	15mil
ProSTUD 20	18mil

### Conventional Drywall Framing

25 Gauge	18mil
20 Gauge	30mil

Allowable Bending Capacity, 3-5/8" Stud

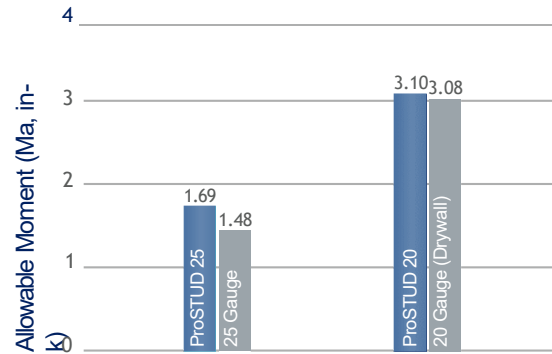

#6 Screw Pullout Values

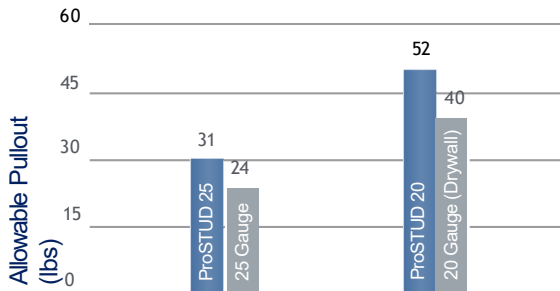

#6 Screw Shear (Bearing) Values

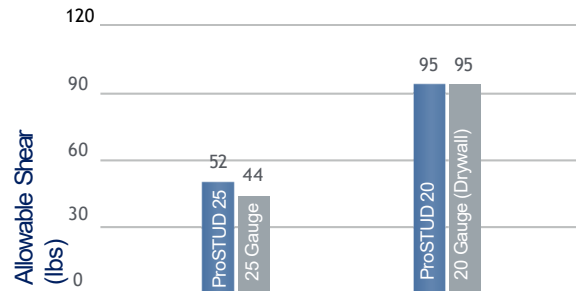

Along with connection capacity, conventional framing members are required to meet performance criteria for screw spinout. ProSTUD was developed with screw performance in mind. High-strength steel, flange stiffening grooves, web embossments, and knurling features combine to provide the best performance per thickness, exceeding the requirements of AISI S220.

Complies with IBC 2021 • AISI S100 • AISI S220.

## Construction Advantages

- High-Strength Steel combined with low-profile flange stiffening grooves and double offset web planking increases strength and provides greater limiting heights
- Diamond-embossed web creates stiffness, reducing flange fade and screw spinout during drywall installation
- Strong lightweight stud and track cuts and handles easier than conventional flat steel studs
- Flange grooves provide sight line for drywall alignment and aid in positioning screws at drywall joints to maintain the 3/8" edge requirement
- Web and leg enhancements in ProTRAK® provide straight and rigid legs, making it the best choice for framing walls, headers, soffits, and bulkheads

## Design Advantages

- Designed to meet the additional strength requirements of today's building codes: IBC 2021, AISI S100, S220, S916, and ICC-ES AC46, and AC86
- UL Classified and listed in over 50 designs, including U419, V438, and chase wall assemblies
- Exceptional sound performance in over 30 tested sound assemblies
- Can contribute LEED® points in LEED v4.1 or v4.EPD and HPD verifications also available.
- Nationally availability.

## ProSTUD®

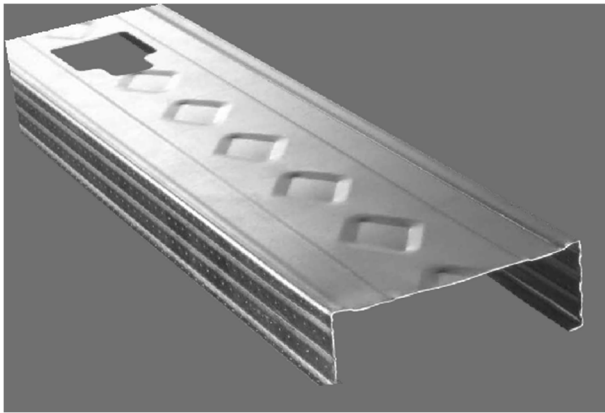

- Web widths: 1-5/8," 2-1/2," 3-1/2," 3-5/8," 4," 5-1/2," and 6"
- Flange: 1-1/4"
- Return lip: varies by stud size
- Material thickness
- ProSTUD 25 / 15mil (25ga EQ) 50ksi ProSTUD 20 / 18mil (20ga EQ) 70ksi ProSTUD 30MIL 33ksi ProSTUD 33MIL 33ksi
- G40EQ is standard, G40 available upon request.
- Other coatings available as special order: G60 and G90.

### ProSTUD Profile

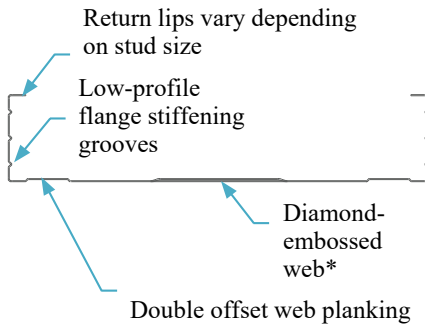

### Shipping / Stacking

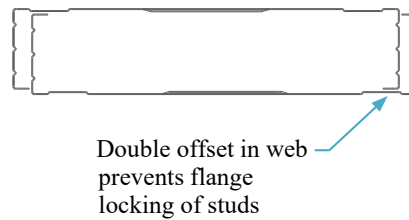

### Drywall Joint

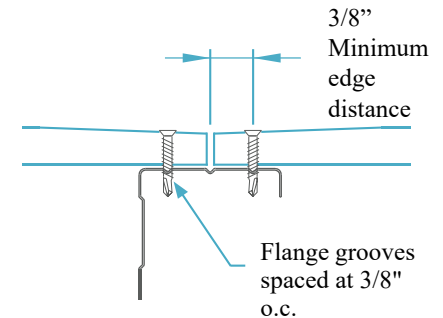

## ProTRAK

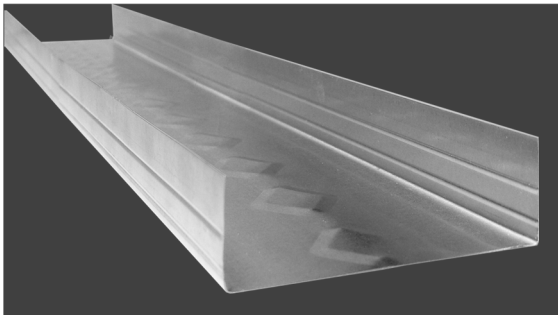

- Web Widths: 1-5/8," 2-1/2," 3-1/2," 3-5/8," 4," 5-1/2," and 6"
- Legs: 1," 1-1/4," 1-1/2," 2," 2-1/2," and 3"
- *\*Not all combinations of web, leg, and gauge are available.*
- Material Thicknesses:  
ProTRAK 25 / 15mil (25ga EQ) 50ksi  
ProTRAK 20 / 18mil (20ga EQ) 50ksi  
ProTRAK 30MIL 33ksi  
ProTRAK 33MIL 33ksi
- G40EQ is standard, G40 available upon request.
- Other coatings available as special order: G60 and G90.

Complies with IBC 2021 • AISI S100 • AISI S220.

## Drywall Framing System - ProSTUD & ProTRAK

Industry standard nomenclature is used to identify MBA's products. The standard designation codes for drywall studs and track can be found on each finished product member. In each case, the identification starts with the measurement of the width of the member, followed by a letter (PDS = stud and PDT = track) followed by the flange dimension. A hyphen is used to separate all of this from the thickness of the metal.

### Style:

(Example: Stud or Joist Section = PDS)

Relevant alpha characters utilized by the designation system are:

PDS = Stud or Joist Sections PDT = Track Sections

### Material Thickness:

(Example: 0.015 in. = 15 mils; 1 mil = 1/1000 in.)

Material thickness is the minimum base metal thickness in mils.

Minimum base metal thickness represents 95% of the design thickness.

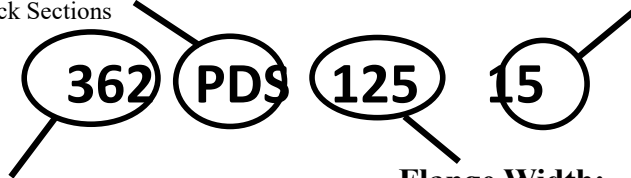

### Member Depth:

(Example: 3-5/8" = 3.625" 362 x 1/100 inches)

All member depths are taken in 1/100 inches. For all "PT" sections member depth is the inside to inside dimension.

### Flange Width:

(Example: 1-1/4" = 1.25" = 125 x 1/100 inches)

All flange widths are taken in 1/100 inches.

### Steel Thickness

Mils	Gauge	Thickness (in)	
		Design	Minimum <sup>1</sup>
15	25	0.0158	0.0150
18	20	0.0190	0.0185
30	20	0.0312	0.0300
33	20	0.0346	0.0330

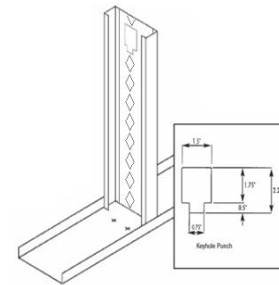

### ProSTUD Punchouts

Drywall studs are manufactured with punchouts to enable plumbing and wiring installation. The lowest punchout is centered 12" from the bottom and 24" or 48" o.c thereafter, with the final opening 12" minimum from the top. Care should be taken during installation to orient all studs in the same top-to-bottom direction.

<sup>1</sup> Minimum Thickness represents 95% of the design thickness and is the minimum acceptable thickness delivered to the job site based on AISI S100-16/S2-20.

## General Notes

- Physical properties and load tables have been calculated in conformance with the AISI S100-16/S2-20.
- Allowable composite heights are calculated using ICC-ES AC86-2010. The 1/3 stress increase was not used.
- Drywall framing members have a protective coating conforming to ASTM spec A 653/A 653M, G-40 min, or equivalent corrosion resistance.
- Reference ASTM specification A 1003/A 1003 M table 1 for the universe of allowable coatings for light gauge steel framing.
- Drywall framing members are marked with product information per the requirements of ASTM C 645 section 14.
- All delivered material must be kept dry, preferably by being stored inside a building under a roof. If it is necessary to store material outside, it must be stacked off the ground, properly supported on a level platform, and fully protected from the weather. Reference ASTM C 754 section 8 and ASTM C 1007 section 4.
- Drywall framing [nonstructural 25 gauge, and 20 gauge] is not permitted in load bearing (i.e. axial load greater than 200 lbs.) or exterior applications (i.e. transverse load greater than 10 PSF). Reference ASTM C 645 section 3.2.2.

## LEED Green Building Credits

MR Credit 2: Construction Waste Management – MBA steel framing is 100% recyclable.

MR Credit 4: Recycled Content – MBA steel framing is formed from no less than 25.5% post-consumer and 6.8% pre-consumer recycled content.

MR Credit 5: Regional Materials – MBA has manufacturing facilities in multiple states.

## 15mil ProSTUD and ProTRAK physical and Structural Properties

### ProSTUD® 25 (15mil) Drywall Stud

Member	Design thickness (in)	Fy (ksi)	Gross Section Properties						Effective Section Properties at Fy						Torsional Properties					Lu (in)
			Area (in <sup>2</sup> )	Weight (lb/ft)	Ix (in <sup>4</sup> )	Rx (in)	Iy (in <sup>4</sup> )	Ry (in)	Ae (in <sup>2</sup> )	Ix (in <sup>4</sup> )	Sx (in <sup>3</sup> )	Ma (in-lbs)	Vag (lb)	Vanet (lb)	Jx1000 (in <sup>4</sup> )	Cw (in <sup>6</sup> )	Xo (in)	Ro (in)	β Beta	
162PDS125-15	0.0158	50	0.071	0.24	0.033	0.688	0.015	0.466	0.033	0.030	0.024	719	232	104	0.00589	0.009	-1.088	1.369	0.368	24.8
250PDS125-15	0.0158	50	0.085	0.29	0.088	1.020	0.018	0.459	0.033	0.080	0.044	1198	147	141	0.00704	0.023	-0.959	1.473	0.576	24.5
362PDS125-15 <sup>1</sup>	0.0158	50	0.102	0.35	0.206	1.420	0.020	0.442	0.034	0.190	0.056	1689	100	100	0.00852	0.051	-0.837	1.706	0.760	24.3
400PDS125-15 <sup>1</sup>	0.0158	50	0.108	0.37	0.260	1.549	0.021	0.436	0.034	0.233	0.062	1870	90	90	0.00901	0.064	-0.803	1.798	0.800	24.2
600PDS125-15 <sup>2</sup>	0.0158	50	0.140	0.48	0.683	2.209	0.023	0.404	0.034	0.537	0.105	2781	60	60	0.01164	0.161	-0.666	2.343	0.919	23.6

### ProTRAK® 25 (15mil) Drywall Track

Member	Design thickness (in)	Fy (ksi)	Gross Section Properties						Effective Section Properties at Fy						Torsional Properties				
			Area (in <sup>2</sup> )	Weight (lb/ft)	Ix (in <sup>4</sup> )	Rx (in)	Iy (in <sup>4</sup> )	Ry (in)	Ae (in <sup>2</sup> )	Ix (in <sup>4</sup> )	Sx (in <sup>3</sup> )	Ma (in-lbs)	Vag (lb)	Jx1000 (in <sup>4</sup> )	Cw (in <sup>6</sup> )	Xo (in)	Ro (in)	β Beta	
162PDT125-15	0.0158	50	0.065	0.22	0.034	0.717	0.011	0.412	0.020	0.021	0.016	464	222	222	0.00542	0.006	-0.881	1.208	0.468
250PDT125-15	0.0158	50	0.079	0.27	0.085	1.038	0.013	0.400	0.020	0.059	0.024	724	143	143	0.00657	0.015	-0.771	1.353	0.675
362PDT125-15 <sup>1</sup>	0.0158	50	0.097	0.33	0.196	1.425	0.014	0.381	0.021	0.125	0.035	1059	98	98	0.00805	0.034	-0.668	1.619	0.830
400PDT125-15 <sup>1</sup>	0.0158	50	0.103	0.35	0.247	1.550	0.014	0.374	0.021	0.153	0.039	1171	89	89	0.00854	0.043	-0.640	1.718	0.861
600PDT125-15 <sup>2</sup>	0.0158	50	0.134	0.46	0.646	2.194	0.016	0.343	0.021	0.350	0.059	1762	59	59	0.01117	0.108	-0.524	2.282	0.947
162PDT200-15	0.0158	50	0.089	0.30	0.050	0.752	0.039	0.663	0.020	0.025	0.015	455	222	222	0.00739	0.020	-1.579	1.870	0.287
250PDT200-15	0.0158	50	0.103	0.35	0.124	1.098	0.045	0.662	0.021	0.064	0.024	720	143	143	0.00854	0.052	-1.431	1.921	0.445
362PDT200-15 <sup>1</sup>	0.0158	50	0.120	0.41	0.277	1.516	0.051	0.648	0.021	0.137	0.036	1063	98	98	0.01002	0.120	-1.282	2.088	0.623
400PDT200-15 <sup>1</sup>	0.0158	50	0.126	0.43	0.344	1.650	0.052	0.642	0.021	0.168	0.039	1178	89	89	0.01052	0.151	-1.240	2.162	0.671
600PDT200-15 <sup>2</sup>	0.0158	50	0.158	0.54	0.864	2.338	0.058	0.608	0.021	0.389	0.060	1789	59	59	0.01315	0.383	-1.058	2.638	0.839
162PDT250-15	0.0158	50	0.105	0.36	0.061	0.766	0.071	0.824	0.020	0.027	0.015	455	222	222	0.00871	0.038	-2.058	2.345	0.230
250PDT250-15	0.0158	50	0.118	0.40	0.150	1.123	0.082	0.831	0.021	0.066	0.024	725	143	143	0.00986	0.096	-1.892	2.352	0.353
362PDT250-15 <sup>1</sup>	0.0158	50	0.136	0.46	0.330	1.557	0.092	0.823	0.021	0.142	0.036	1073	98	98	0.01134	0.220	-1.720	2.462	0.512
400PDT250-15 <sup>1</sup>	0.0158	50	0.142	0.48	0.409	1.696	0.095	0.819	0.021	0.174	0.040	1189	89	89	0.01183	0.275	-1.670	2.517	0.560
600PDT250-15 <sup>2</sup>	0.0158	50	0.174	0.59	1.009	2.409	0.108	0.787	0.021	0.404	0.060	1809	59	59	0.01446	0.697	-1.452	2.921	0.753

Notes:

- Calculated properties are based on AISI S100-16 (2020) w/S2-20 North American Specification for Design of Cold-Formed Steel Structural Members and AISI S220-20 North American Standard for Cold-Formed Steel Framing— Nonstructural Members.
- Effective properties incorporate the strength increase from the cold work of forming as applicable per Section A3.3.2 of AISI S100-16 (2020) w/S2-20.
- Tabulated gross properties, including torsional properties, are based on full-unreduced cross section of the studs, away from punchouts.
- Tabulated gross properties, including torsional properties, are based on full-unreduced cross section of the tracks.
- For deflection calculations, use the effective moment of inertia.
- Allowable moment includes cold work of forming.
- Allowable moment is taken as the lowest value based on local or distortional buckling. Distortional buckling strength is based on a k-phi = 0.
- Web depth for track sections is equal to the nominal height plus two times the design thickness plus the bend radius. Hems on nonstructural track sections are ignored.
- 1 Web-height to thickness ratio exceeds 200.
- 2 Web-height to thickness ratio exceeds 260.

Complies with IBC 2021 • AISI S100 • AISI S220

## 18mil ProSTUD and ProTRAK physical and Structural Properties

### ProSTUD® 20 (18mil) Drywall Stud

Member	Design thickness (in)	Fy (ksi)	Gross Section Properties						Effective Section Properties at Fy						Torsional Properties					Lu (in)
			Area (in <sup>2</sup> )	Weight (lb/ft)	Ix (in <sup>4</sup> )	Rx (in)	Iy (in <sup>4</sup> )	Ry (in)	Ae (in <sup>2</sup> )	Ix (in <sup>4</sup> )	Sx (in <sup>3</sup> )	Ma (in-lbs)	Vag (lb)	Vanet (lb)	Jx1000 (in <sup>4</sup> )	Cw (in <sup>6</sup> )	Xo (in)	Ro (in)	β Beta	
162PDS125-18	0.0190	70	0.086	0.29	0.040	0.685	0.019	0.468	0.039	0.035	0.028	1194	405	149	0.01032	0.012	-1.105	1.382	0.361	24.8
250PDS125-18	0.0190	70	0.104	0.35	0.107	1.017	0.023	0.470	0.043	0.099	0.056	2361	256	204	0.01250	0.031	-1.004	1.504	0.555	24.5
362PDS125-18	0.0190	70	0.126	0.43	0.254	1.421	0.026	0.456	0.044	0.234	0.074	3102	174	170	0.01512	0.070	-0.884	1.734	0.740	24.3
400PDS125-18 <sup>1</sup>	0.0190	70	0.133	0.45	0.321	1.551	0.027	0.453	0.046	0.286	0.084	3532	157	157	0.01605	0.089	-0.859	1.830	0.780	24.2
600PDS125-18 <sup>2</sup>	0.0190	70	0.173	0.59	0.855	2.223	0.032	0.431	0.046	0.669	0.141	5891	104	104	0.02083	0.233	-0.739	2.382	0.904	23.6

### ProTRAK® 20 (18mil) Drywall Track

Member	Design thickness (in)	Fy (ksi)	Gross Section Properties						Effective Section Properties at Fy						Torsional Properties					
			Area (in <sup>2</sup> )	Weight (lb/ft)	Ix (in <sup>4</sup> )	Rx (in)	Iy (in <sup>4</sup> )	Ry (in)	Ae (in <sup>2</sup> )	Ix (in <sup>4</sup> )	Sx (in <sup>3</sup> )	Ma (in-lbs)	Vag (lb)	Jx1000 (in <sup>4</sup> )	Cw (in <sup>6</sup> )	Xo (in)	Ro (in)	β Beta		
162PDT125-18	0.0190	50	0.078	0.27	0.040	0.718	0.013	0.411	0.028	0.027	0.022	663	380	0.00943	0.007	-0.879	1.207	0.470		
250PDT125-18	0.0190	50	0.095	0.32	0.102	1.038	0.015	0.400	0.029	0.073	0.034	1029	248	0.01143	0.017	-0.770	1.353	0.676		
362PDT125-18	0.0190	50	0.116	0.40	0.236	1.426	0.017	0.380	0.029	0.173	0.050	1497	170	0.01400	0.041	-0.666	1.619	0.831		
400PDT125-18	0.0190	50	0.123	0.42	0.297	1.550	0.017	0.374	0.029	0.211	0.055	1653	154	0.01486	0.051	-0.638	1.718	0.862		
600PDT125-18 <sup>2</sup>	0.0190	50	0.161	0.55	0.778	2.195	0.019	0.342	0.029	0.469	0.083	2473	102	0.01943	0.130	-0.523	2.282	0.947		
162PDT200-18	0.0190	50	0.107	0.36	0.061	0.753	0.047	0.662	0.028	0.032	0.021	642	380	0.01285	0.024	-1.577	1.869	0.288		
250PDT200-18	0.0190	50	0.123	0.42	0.149	1.099	0.054	0.661	0.029	0.088	0.034	1016	248	0.01486	0.063	-1.429	1.920	0.446		
362PDT200-18	0.0190	50	0.145	0.49	0.333	1.517	0.061	0.648	0.029	0.188	0.050	1500	170	0.01743	0.145	-1.280	2.088	0.624		
400PDT200-18	0.0190	50	0.152	0.52	0.414	1.651	0.063	0.642	0.029	0.230	0.055	1661	154	0.01828	0.181	-1.238	2.161	0.672		
600PDT200-18 <sup>2</sup>	0.0190	50	0.190	0.65	1.039	2.339	0.070	0.607	0.030	0.532	0.084	2525	102	0.02286	0.461	-1.057	2.637	0.840		
162PDT250-18	0.0190	50	0.126	0.43	0.074	0.767	0.085	0.823	0.028	0.035	0.021	635	380	0.01514	0.045	-2.056	2.344	0.231		
250PDT250-18	0.0190	50	0.142	0.48	0.180	1.125	0.098	0.830	0.029	0.091	0.034	1011	248	0.01714	0.115	-1.891	2.351	0.353		
362PDT250-18	0.0190	50	0.164	0.56	0.398	1.558	0.111	0.823	0.029	0.195	0.050	1498	170	0.01971	0.264	-1.718	2.461	0.512		
400PDT250-18	0.0190	50	0.171	0.58	0.492	1.697	0.114	0.818	0.029	0.239	0.055	1661	154	0.02057	0.331	-1.669	2.517	0.560		
600PDT250-18 <sup>2</sup>	0.0190	50	0.209	0.71	1.214	2.410	0.129	0.786	0.030	0.555	0.085	2533	102	0.02514	0.838	-1.450	2.920	0.753		

Notes:

- Calculated properties are based on AISI S100-16 (2020) w/S2-20 North American Specification for Design of Cold-Formed Steel Structural Members and AISI S220-20 North American Standard for Cold-Formed Steel Framing—Nonstructural Members.
- Effective properties incorporate the strength increase from the cold work of forming as applicable per Section A3.3.2 of AISI S100-16 (2020) w/S2-20.
- Tabulated gross properties, including torsional properties, are based on full-unreduced cross section of the studs, away from punchouts.
- Tabulated gross properties, including torsional properties, are based on full-unreduced cross section of the tracks.
- For deflection calculations, use the effective moment of inertia.
- Allowable moment includes cold work of forming.
- Allowable moment is taken as the lowest value based on local or distortional buckling. Distortional buckling strength is based on a k-phi = 0.
- Web depth for track sections is equal to the nominal height plus two times the design thickness plus the bend radius. Hems on nonstructural track sections are ignored.
- 1 Web-height to thickness ratio exceeds 200.
- 2 Web-height to thickness ratio exceeds 260.

Complies with IBC 2021 • AISI S100 • AISI S220

## 30mil ProSTUD and ProTRAK Physical and Structural Properties

### ProSTUD® 30mil Drywall Stud (Available Upon Request)

Member	Design thickness (in)	Fy (ksi)	Gross Section Properties						Effective Section Properties at Fy						Torsional Properties					Lu (in)
			Area (in <sup>2</sup> )	Weight (lb/ft)	Ix (in <sup>4</sup> )	Rx (in)	Iy (in <sup>4</sup> )	Ry (in)	Ae (in <sup>2</sup> )	Ix (in <sup>4</sup> )	Sx (in <sup>3</sup> )	Ma (in-lbs)	Vag (lb)	Vanet (lb)	J*1000 (in <sup>4</sup> )	Cw (in <sup>6</sup> )	Xo (in)	Ro (in)	β Beta	
162PDS125-30	0.0312	33	0.137	0.47	0.064	0.681	0.029	0.458	0.098	0.064	0.067	1332	572	124	0.04459	0.017	-1.070	1.348	0.371	30.8
250PDS125-30	0.0312	33	0.165	0.56	0.169	1.012	0.034	0.451	0.106	0.168	0.121	2356	832	397	0.05345	0.042	-0.941	1.454	0.581	30.1
362PDS125-30	0.0312	33	0.200	0.68	0.398	1.411	0.038	0.434	0.107	0.396	0.170	3358	776	457	0.06484	0.096	-0.820	1.689	0.764	29.7
400PDS125-30	0.0312	33	0.212	0.72	0.501	1.540	0.039	0.428	0.108	0.499	0.189	3737	701	490	0.06864	0.120	-0.787	1.781	0.805	29.5
600PDS125-30	0.0312	33	0.274	0.93	1.324	2.199	0.043	0.396	0.109	1.281	0.338	6031	461	461	0.08888	0.303	-0.651	2.327	0.922	28.7

### ProTRAK® 30mil Drywall Track (Available Upon Request)

Member	Design thickness (in)	Fy (ksi)	Gross Section Properties						Effective Section Properties at Fy						Torsional Properties				
			Area (in <sup>2</sup> )	Weight (lb/ft)	Ix (in <sup>4</sup> )	Rx (in)	Iy (in <sup>4</sup> )	Ry (in)	Ae (in <sup>2</sup> )	Ix (in <sup>4</sup> )	Sx (in <sup>3</sup> )	Ma (in-lbs)	Vag (lb)	J*1000 (in <sup>4</sup> )	Cw (in <sup>6</sup> )	Xo (in)	Ro (in)	β Beta	
162PDT125-30	0.0312	33	0.128	0.44	0.067	0.722	0.022	0.409	0.080	0.054	0.048	951	610	0.04168	0.011	-0.872	1.204	0.475	
250PDT125-30	0.0312	33	0.156	0.53	0.169	1.042	0.025	0.397	0.084	0.140	0.087	1713	832	0.05054	0.029	-0.763	1.351	0.681	
362PDT125-30	0.0312	33	0.191	0.65	0.389	1.428	0.027	0.378	0.087	0.330	0.149	2938	755	0.06193	0.067	-0.661	1.619	0.833	
400PDT125-30	0.0312	33	0.203	0.69	0.489	1.553	0.028	0.371	0.088	0.417	0.172	3407	683	0.06573	0.084	-0.633	1.718	0.864	
600PDT125-30	0.0312	33	0.265	0.90	1.278	2.196	0.031	0.340	0.090	1.074	0.240	4737	454	0.08597	0.212	-0.519	2.282	0.948	
162PDT200-30	0.0312	33	0.175	0.60	0.101	0.758	0.076	0.660	0.081	0.067	0.052	1028	610	0.05687	0.040	-1.570	1.864	0.291	
250PDT200-30	0.0312	33	0.203	0.69	0.246	1.103	0.088	0.659	0.086	0.170	0.094	1862	832	0.06573	0.103	-1.423	1.917	0.449	
362PDT200-30	0.0312	33	0.238	0.81	0.549	1.520	0.099	0.645	0.089	0.397	0.160	3159	755	0.07712	0.237	-1.274	2.086	0.627	
400PDT200-30	0.0312	33	0.249	0.85	0.682	1.654	0.102	0.639	0.089	0.502	0.176	3480	683	0.08091	0.297	-1.232	2.160	0.674	
600PDT200-30	0.0312	33	0.312	1.06	1.710	2.342	0.114	0.605	0.091	1.353	0.262	5170	454	0.10116	0.754	-1.051	2.637	0.841	
162PDT250-30	0.0312	33	0.206	0.70	0.123	0.772	0.139	0.821	0.082	0.073	0.054	1059	610	0.06699	0.075	-2.048	2.338	0.233	
250PDT250-30	0.0312	33	0.234	0.80	0.298	1.129	0.160	0.828	0.086	0.186	0.097	1926	832	0.07585	0.190	-1.883	2.347	0.356	
362PDT250-30	0.0312	33	0.269	0.92	0.656	1.562	0.181	0.820	0.089	0.436	0.157	3097	755	0.08724	0.435	-1.712	2.458	0.515	
400PDT250-30	0.0312	33	0.281	0.96	0.812	1.701	0.187	0.816	0.090	0.551	0.173	3425	683	0.09104	0.543	-1.662	2.514	0.563	

**Notes:**

- Calculated properties are based on AISI S100-16 (2020) w/S2-20 North American Specification for Design of Cold-Formed Steel Structural Members and AISI S220-20 North American Standard for Cold-Formed Steel Framing—Nonstructural Members.
- Effective properties incorporate the strength increase from the cold work of forming as applicable per Section A3.3.2 of AISI S100-16 (2020) w/S2-20.
- Tabulated gross properties, including torsional properties, are based on full-unreduced cross section of the studs, away from punchouts.
- Tabulated gross properties, including torsional properties, are based on full-unreduced cross section of the tracks.
- For deflection calculations, use the effective moment of inertia.
- Allowable moment includes cold work of forming.
- Allowable moment is taken as the lowest value based on local or distortional buckling. Distortional buckling strength is based on a k-phi = 0.
- Web depth for track sections is equal to the nominal height plus two times the design thickness plus the bend radius. Hems on nonstructural track sections are ignored.
- 1 Web-height to thickness ratio exceeds 200.
- 2 Web-height to thickness ratio exceeds 260.

Complies with IBC 2021 • AISI S100 • AISI S220

## 33mil ProSTUD and ProTRAK physical and Structural Properties

### ProSTUD® 33mil Drywall Stud (Available Upon Request)

Member	Design thickness (in)	Fy (ksi)	Gross Section Properties						Effective Section Properties at Fy						Torsional Properties					Lu (in)
			Area (in <sup>2</sup> )	Weight (lb/ft)	Ix (in <sup>4</sup> )	Rx (in)	Iy (in <sup>4</sup> )	Ry (in)	Ae (in <sup>2</sup> )	Ix (in <sup>4</sup> )	Sx (in <sup>3</sup> )	Ma (in-lbs)	Vag (lb)	Vanet (lb)	J*1000 (in <sup>4</sup> )	Cw (in <sup>6</sup> )	Xo (in)	Ro (in)	β Beta	
162PDS125-33	0.0346	33	0.152	0.52	0.070	0.679	0.032	0.456	0.114	0.070	0.078	1541	632	123	0.06059	0.019	-1.065	1.344	0.371	30.8
250PDS125-33	0.0346	33	0.182	0.62	0.186	1.010	0.037	0.449	0.125	0.186	0.138	2697	1007	431	0.07267	0.046	-0.937	1.449	0.582	30.1
362PDS125-33	0.0346	33	0.221	0.75	0.439	1.409	0.041	0.433	0.127	0.439	0.200	3943	1024	541	0.08820	0.106	-0.816	1.685	0.766	29.6
400PDS125-33	0.0346	33	0.234	0.80	0.553	1.538	0.043	0.426	0.128	0.553	0.222	4394	957	602	0.09338	0.132	-0.783	1.777	0.806	29.5
600PDS125-33	0.0346	33	0.303	1.03	1.463	2.196	0.047	0.394	0.130	1.428	0.399	7021	630	630	0.12100	0.332	-0.647	2.323	0.922	28.6

### ProTRAK® 33mil Drywall Track (Available Upon Request)

Member	Design thickness (in)	Fy (ksi)	Gross Section Properties						Effective Section Properties at Fy						Torsional Properties				
			Area (in <sup>2</sup> )	Weight (lb/ft)	Ix (in <sup>4</sup> )	Rx (in)	Iy (in <sup>4</sup> )	Ry (in)	Ae (in <sup>2</sup> )	Ix (in <sup>4</sup> )	Sx (in <sup>3</sup> )	Ma (in-lbs)	Vag (lb)	J*1000 (in <sup>4</sup> )	Cw (in <sup>6</sup> )	Xo (in)	Ro (in)	β Beta	
162PDT125-33	0.0346	33	0.142	0.48	0.075	0.723	0.024	0.409	0.095	0.063	0.056	1104	677	0.05683	0.012	-0.870	1.203	0.477	
250PDT125-33	0.0346	33	0.173	0.59	0.188	1.043	0.027	0.397	0.102	0.160	0.100	1972	1024	0.06891	0.032	-0.762	1.351	0.682	
362PDT125-33	0.0346	33	0.212	0.72	0.432	1.429	0.030	0.377	0.105	0.375	0.170	3358	1024	0.08444	0.074	-0.659	1.618	0.834	
400PDT125-33	0.0346	33	0.225	0.77	0.542	1.554	0.031	0.371	0.106	0.473	0.197	3887	931	0.08962	0.093	-0.632	1.718	0.865	
600PDT125-33	0.0346	33	0.294	1.00	1.418	2.197	0.034	0.339	0.109	1.237	0.287	5681	619	0.11723	0.234	-0.517	2.282	0.949	
162PDT200-33	0.0346	33	0.194	0.66	0.112	0.759	0.085	0.660	0.097	0.077	0.061	1198	677	0.07754	0.045	-1.568	1.862	0.292	
250PDT200-33	0.0346	33	0.225	0.77	0.274	1.104	0.097	0.658	0.104	0.196	0.109	2150	1024	0.08962	0.114	-1.421	1.916	0.450	
362PDT200-33	0.0346	33	0.264	0.90	0.610	1.521	0.110	0.645	0.107	0.452	0.186	3669	1024	0.10515	0.263	-1.272	2.085	0.628	
400PDT200-33	0.0346	33	0.276	0.94	0.758	1.655	0.113	0.639	0.108	0.567	0.215	4246	931	0.11033	0.329	-1.230	2.159	0.675	
600PDT200-33	0.0346	33	0.346	1.18	1.897	2.342	0.126	0.604	0.111	1.520	0.322	6355	619	0.13795	0.835	-1.050	2.637	0.842	
162PDT250-33	0.0346	33	0.229	0.78	0.137	0.774	0.154	0.821	0.098	0.085	0.063	1235	677	0.09135	0.083	-2.046	2.336	0.233	
250PDT250-33	0.0346	33	0.259	0.88	0.331	1.130	0.177	0.827	0.104	0.214	0.113	2225	1024	0.10343	0.211	-1.881	2.346	0.357	
362PDT250-33	0.0346	33	0.298	1.01	0.728	1.563	0.200	0.820	0.108	0.493	0.193	3808	1024	0.11896	0.482	-1.710	2.457	0.516	
400PDT250-33	0.0346	33	0.311	1.06	0.901	1.702	0.207	0.815	0.109	0.622	0.214	4221	931	0.12414	0.602	-1.660	2.514	0.564	
600PDT250-33	0.0346	33	0.380	1.29	2.216	2.414	0.233	0.783	0.111	1.657	0.320	6327	619	0.15175	1.522	-1.443	2.919	0.756	

Notes:

- Calculated properties are based on AISI S100-16 (2020) w/S2-20 North American Specification for Design of Cold-Formed Steel Structural Members and AISI S220-20 North American Standard for Cold-Formed Steel Framing—Nonstructural Members.
- Effective properties incorporate the strength increase from the cold work of forming as applicable per Section A3.3.2 of AISI S100-16 (2020) w/S2-20.
- Tabulated gross properties, including torsional properties, are based on full-unreduced cross section of the studs, away from punchouts.
- Tabulated gross properties, including torsional properties, are based on full-unreduced cross section of the tracks.
- For deflection calculations, use the effective moment of inertia.
- Allowable moment includes cold work of forming.
- Allowable moment is taken as the lowest value based on local or distortional buckling. Distortional buckling strength is based on a k-phi = 0.
- Web depth for track sections is equal to the nominal height plus two times the design thickness plus the bend radius. Hems on nonstructural track sections are ignored.
- 1 Web-height to thickness ratio exceeds 200.
- 2 Web-height to thickness ratio exceeds 260.

Complies with IBC 2021 • AISI S100 • AISI S220

## Head-of-Wall (HOW) Composite Using Deflection Track

### HOW Composite Wall 30mil 2-1/2" DeepLeg Deflection Track

HOW Composite limiting heights were tested in accordance with AISI S916 and ICC-ES AC86.

The tests were modified from the standards with the tracks fastened to the test fixture such that the wall stiffness included the track deformation.

It is important to note that a wall designed using limiting heights from HOW composite tables must be constructed consistent with notes listed below the HOW Composite limiting heights tables.

#### Use of Head-of-Wall Composite tables if your wall meets these conditions:

- Maximum deflection gap is 7/8" or less
- Meets the requirements of the most common 1/2" and 3/4" deflection gap
- For use of the following Deflection Tracks:
- 30mil 2-1/2" Deep Leg Deflection Track
  - Thicker Deep Leg Deflection Track noted above are allowed but won't increase limiting heights without
- 5/8" Type X Gypsum board applied full height in the vertical orientation
  - (Leaving a 7/8" max. deflection gap and not having the board attached to the top deflection track is allowed.)

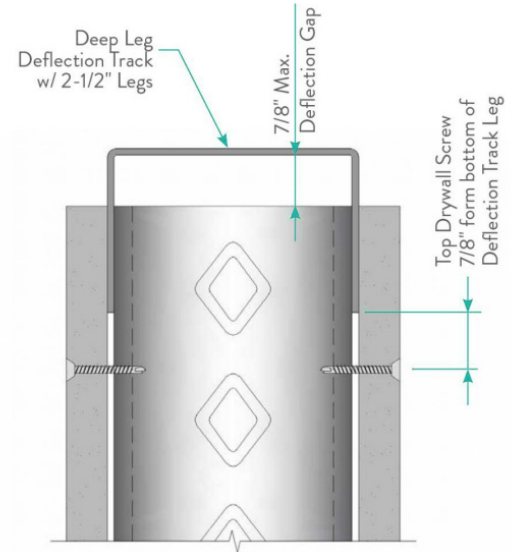

## Full Composite Assemblies

### Full Composite wall w/ 1-1/4" Leg Non-Deflection Track

Full Composite limiting Height Data can be applied to walls where gypsum board is installed vertically on both flanges of the stud, for the full height of the wall and attached to the top and bottom tracks. ProSTUD composite data is based on the 2021 International Building Code and was tested and analyzed in accordance with AISI S916 and ICC-ES AC86. Composite limiting height tables for ProSTUD members are available and starting on Page 20.

#### Not to be used with:

- Deflection Tracks
- Resilient Channel
- Sound Clips
- 1/2" Gypsum Board
- Horizontally Installed Board

It is important to note that a wall designed using limited heights from composite tables must be constructed consistent with the assembly as it was tested per AISI S916 and ICC-ES AC86

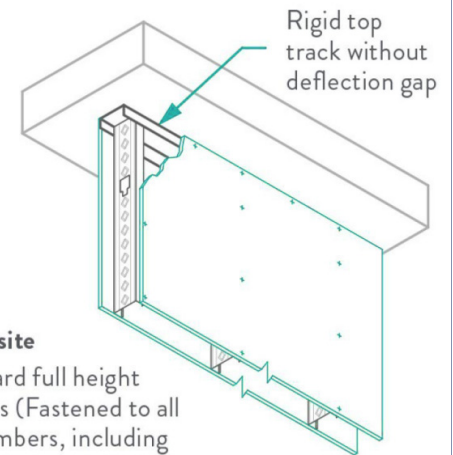

#### Full Composite

Gypsum board full height on both sides (Fastened to all framing members, including top and bottom tracks)

Complies with IBC 2021 • AISI S100 • AISI S220.

## Limiting Wall Heights (cont'd)

### ProSTUD® 25/15mil Head-of-Wall (HOW) Composite Limiting Heights w/30mil 2-1/2" Leg Deflection Track

Width	Section	Yield Strength	Spacing (in) o.c.	5psf			7.5psf			10psf		
				L/120	L/240	L/360	L/120	L/240	L/360	L/120	L/240	L/360
3-5/8"	362PDS125-15	50 ksi	12	19' - 9"	16' - 6"	14' - 6"	16' - 10" f	14' - 5"	12' - 8"	14' - 7" f	13' - 1"	11' - 3"
			16	18' - 7"	15' - 6"	13' - 7"	15' - 4" f	13' - 7"	11' - 10"	13' - 3" f	12' - 4"	10' - 3"
			24	15' - 10" f	13' - 7"	11' - 10"	12' - 11" f	11' - 10"	10' - 1"	11' - 2" f	10' - 7"	8' - 10"
4"	400PDS125-15	50 ksi	12	20' - 11"	17' - 6"	15' - 3"	18' - 0" f	15' - 3"	13' - 4"	15' - 7" f	13' - 11"	12' - 1"
			16	19' - 9"	16' - 4"	14' - 4"	16' - 4" f	14' - 4"	12' - 6"	14' - 2" f	13' - 0"	11' - 2"
			24	16' - 6" f	14' - 4"	12' - 6"	13' - 6" f	12' - 6"	10' - 8"	11' - 8" f	11' - 3"	9' - 6"
6"	600PDS125-15	50 ksi	12	27' - 10" f	23' - 8"	20' - 8"	22' - 9" f	20' - 8"	18' - 1"	19' - 8" f	18' - 9"	16' - 5"
			16	24' - 1" f	21' - 11"	19' - 5"	19' - 8" f	19' - 2"	17' - 0"	17' - 1" f	17' - 1" f	15' - 2"
			24	19' - 8" f	19' - 2"	17' - 0"	16' - 1" f	16' - 1" f	14' - 9"	13' - 11" f	13' - 11" f	13' - 2"

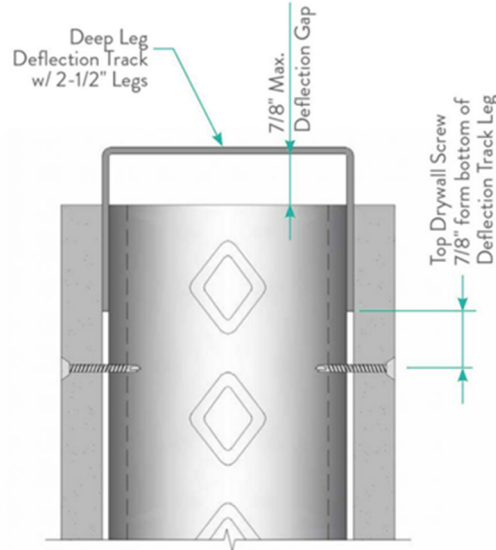

Notes:

- Allowable HOW composite limiting heights were tested in accordance with AISI S916 and ICC-ES AC86.
- The tests were modified from the standards with the tracks fastened to the test fixture such that the wall stiffness included the track deformation.
- In accordance with current building codes and AISI design standards, the 1/3 Stress Increase for strength was not used.
- The composite limiting heights provided in the tables are based on a single layer of 5/8" Type X Gypsum Board from the following manufacturers: American, CertainTeed, Georgia Pacific, Continental, National, PABCO, and USG.
- The gypsum board must be applied full height in the vertical orientation to each stud flange and installed in accordance with ASTM C754 using minimum No.6 Type S Drywall screws spaced as listed below:
- Sheathing screws spaced a maximum of 16 in on-center to framing members (including bottom track) when studs spaced at 16 in or 12 in on-center.
- Sheathing screws spaced a maximum of 12 in on-center to framing members (including bottom track) when studs spaced at 24 in on-center.
- No fasteners are required for attaching the stud to the Deflection track at the top except as detailed in ASTM C754:
- Stud to track connection must be installed as depicted in figure with a maximum gap of 7/8" between the web of the Deflection track and end of stud.
- The maximum amount of total vertical movement (compression + extension) cannot exceed 1-1/2".
- To permit head of wall deflection, gypsum board must not be fastened directly to the Deflection track. - No fasteners are required for attaching the stud to the bottom track except as detailed in ASTM C754.
- A spazzer spacing bar shall be installed in the punchouts immediately adjacent to the top track (Deflection Track) to hold studs in place. f Adjacent to the height value indicates that flexural stress controls the allowable wall height.

Complies with IBC 2021 • AISI S100 • AISI S220

## Limiting Wall Heights (cont'd)

### ProSTUD® 20/18mil Head-of-Wall (HOW) Composite Limiting Heights w/30mil 2-1/2" Leg Deflection Track

Width	Section	Yield Strength	Spacing (in) o.c.	5psf			7.5psf			10psf		
				L/120	L/240	L/360	L/120	L/240	L/360	L/120	L/240	L/360
2-1/2"	250PDS125-18	70 ksi	12	16' - 6"	14' - 1"	12' - 4"	14' - 6"	12' - 4"	10' - 9"	13' - 3"	11' - 2"	9' - 9"
			16	15' - 11"	13' - 5"	11' - 8"	13' - 11"	11' - 8"	10' - 3"	12' - 8"	10' - 8"	9' - 0"
			24	14' - 5"	12' - 2"	10' - 7"	12' - 6" f	10' - 7"	8' - 11"	10' - 10" f	9' - 6"	--
3-5/8"	362PDS125-18	70 ksi	12	21' - 2"	17' - 8"	15' - 5"	18' - 6"	15' - 6"	13' - 5"	16' - 10"	14' - 1"	12' - 3"
			16	19' - 11"	16' - 8"	14' - 6"	17' - 5"	14' - 7"	12' - 8"	15' - 10"	13' - 3"	11' - 3"
			24	18' - 0"	14' - 11"	13' - 0"	15' - 9"	13' - 1"	11' - 1"	13' - 7" f	11' - 10"	9' - 9"
4"	400PDS125-18	70 ksi	12	22' - 5"	18' - 7"	16' - 4"	19' - 7"	16' - 3"	14' - 3"	17' - 10"	14' - 9"	12' - 11"
			16	20' - 10"	17' - 3"	15' - 2"	18' - 3"	15' - 1"	13' - 3"	16' - 7"	13' - 9"	12' - 1"
			24	18' - 7"	15' - 5"	13' - 6"	16' - 3"	13' - 6"	11' - 9"	14' - 2" f	12' - 3"	10' - 2"
6"	600PDS125-18	70 ksi	12	29' - 6"	24' - 8"	21' - 9"	25' - 9"	21' - 6"	19' - 0"	22' - 5" f	19' - 7"	17' - 3"
			16	27' - 9"	23' - 2"	20' - 5"	23' - 4" f	20' - 3"	17' - 10"	20' - 3" f	18' - 5"	16' - 2"
			24	24' - 3" f	20' - 11"	18' - 3"	19' - 10" f	18' - 3"	15' - 11"	17' - 2" f	16' - 7"	13' - 8"

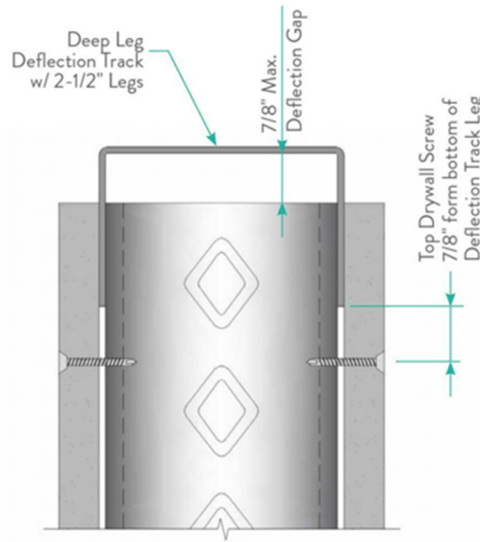

Notes:

- Allowable HOW composite limiting heights were tested in accordance with AISI S916 and ICC-ES AC86.
- The tests were modified from the standards with the tracks fastened to the test fixture such that the wall stiffness included the track deformation.
- In accordance with current building codes and AISI design standards, the 1/3 Stress Increase for strength was not used.
- The composite limiting heights provided in the tables are based on a single layer of 5/8" Type X Gypsum Board from the following manufacturers: American, CertainTeed, Georgia Pacific, Continental, National, PABCO, and USG.
- The gypsum board must be applied full height in the vertical orientation to each stud flange and installed in accordance with ASTM C754 using minimum No.6 Type S Drywall screws spaced as listed below:
  - Sheathing screws spaced a maximum of 16 in on-center to framing members (including bottom track) when studs spaced at 16 in or 12 in on-center.
  - Sheathing screws spaced a maximum of 12 in on-center to framing members (including bottom track) when studs spaced at 24 in on-center.
- No fasteners are required for attaching the stud to the Deflection track at the top except as detailed in ASTM C754:
- Stud to track connection must be installed as depicted in figure with a maximum gap of 7/8" between the web of the Deflection track and end of stud.
- The maximum amount of total vertical movement (compression + extension) cannot exceed 1-1/2".
- To permit head of wall deflection, gypsum board must not be fastened directly to the Deflection track. - No fasteners are required for attaching the stud to the bottom track except as detailed in ASTM C754.
- A spazzer spacing bar shall be installed in the punchouts immediately adjacent to the top track (Deflection Track) to hold studs in place. f Adjacent to the height value indicates that flexural stress controls the allowable wall height.

Complies with IBC 2021 • AISI S100 • AISI S220

## Limiting Wall Heights

### Interior Non-Structural Composite Table Notes

1. Allowable composite limiting heights are calculated using ICC-ES AC86-2019. In accordance with current building codes and AISI design standards, the 1/3 Stress Increase for strength was not used.
2. The composite limiting heights provided in the tables are based on a single layer of Type X Gypsum Board from the following manufacturers: American, CertainTeed, Georgia Pacific, Lafarge, National, Temple Inland, and USG.
3. The gypsum board must be applied full height in the vertical orientation to each stud flange and installed in accordance with ASTM C754 using minimum No.6 Type S Drywall screws spaced a minimum of 12 inch on-center to the framing members.
4. No fasteners are required for attaching the stud to the track except as detailed in ASTM C754.
5. Stud end bearing must be a minimum of 1 inch.
6. Minimum material yield strength equals 65ksi for 19 mil studs.
7. 'f' adjacent to the height value indicates that flexural stress controls the allowable wall height.
8. 's' adjacent to the height value indicates that shear/end reaction controls the allowable wall height.

### Interior Composite data with 1 layer 5/8" Type X Gypsum Board

Depth (in)	Section	Design thickness (in)	Yield strength (ksi)	Spacing (inches)	5psf			7.5psf			10psf		
					L/120	L/240	L/360	L/120	L/240	L/360	L/120	L/240	L/360
1-5/8	162PDS125-15	0.0158	50	12	14' 1"	11' 7"	10' 1"	12' 3"	10' 1"	8' 7"	11' 2"	9' 1"	
				16	12' 9"	10' 6"	9' 0"	11' 2"	9' 1"		10' 2"	8' 1"	
				24	11' 2"	9' 1"		9' 9"			8' 5"		
	162PDS125-18	0.0190	70	12	13' 2"	11' 5"	10' 0"	11' 6"	10' 0"	8' 5"	10' 6"	8' 9"	
				16	12' 10"	11' 1"	9' 9"	11' 2"	9' 8"	7' 11"	10' 2"	8' 4"	
				24	11' 10"	10' 3"	8' 6"	10' 4"	8' 5"		9' 2"		
	162PDS125-30	0.0312	33	12	16' 3"	12' 11"	11' 3"	14' 3"	11' 3"	9' 10"	12' 11"	10' 3"	8' 8"
				16	14' 9"	11' 9"	10' 3"	12' 11"	10' 3"	8' 8"	11' 9"	9' 2"	
				24	12' 11"	10' 3"	8' 8"	11' 3"	8' 8"		10' 3"		
	162PDS125-33	0.0346	33	12	17' 0"	13' 6"	11' 10"	14' 10"	11' 10"	10' 4"	13' 6"	10' 9"	9' 3"
				16	15' 6"	12' 3"	10' 9"	13' 6"	10' 9"	9' 3"	12' 3"	9' 9"	
				24	13' 6"	10' 9"	9' 3"	11' 10"	9' 3"		10' 9"		
2-1/2	250PDS125-15	0.0158	50	12	17' 2"	14' 8"	13' 0"	15' 0"	12' 10"	11' 4"	13' 3" f	11' 8"	10' 4"
				16	15' 7"	13' 4"	11' 9"	13' 3" f	11' 8"	10' 4"	11' 5" f	10' 7"	9' 1"
				24	13' 3" f	11' 8"	10' 4"	10' 10" f	10' 2"	8' 6"	9' 4" f	8' 11"	
	250PDS125-18	0.0190	70	12	17' 5"	14' 8"	12' 11"	15' 3"	12' 10"	11' 3"	13' 10"	11' 8"	10' 3"
				16	16' 8"	14' 0"	12' 4"	14' 6"	12' 3"	10' 9"	13' 2"	11' 2" f	9' 9"
				24	15' 2"	12' 10"	11' 3"	13' 2" f	11' 2"	9' 10"	11' 5" f	10' 2"	8' 5"
	250PDS125-30	0.0312	33	12	19' 9"	16' 3"	14' 4"	17' 3"	14' 2"	12' 6"	15' 8"	12' 11"	11' 4"
				16	17' 11"	14' 9"	13' 0"	15' 8"	12' 11"	11' 4"	14' 3"	11' 9"	10' 4"
				24	15' 8"	12' 11"	11' 4"	13' 8" f	11' 3"	9' 11"	12' 5"	10' 3"	8' 8"
	250PDS125-33	0.0346	33	12	20' 4"	16' 9"	14' 9"	17' 9"	14' 7"	12' 10"	16' 2"	13' 3"	11' 8"
				16	18' 6"	15' 2"	13' 5"	16' 2"	13' 3"	11' 8"	14' 8"	12' 1"	10' 7"
				24	16' 2"	13' 3"	11' 8"	14' 1"	11' 7"	10' 3"	12' 10"	10' 7"	9' 1"

## Limiting Wall Heights (cont'd)

### Interior Composite data with 1 layer 5/8" Type X Gypsum Board

Depth (in)	Section	Design thickness (in)	Yield strength (ksi)	Spacing (inches)	5psf			7.5psf			10psf		
					L/120	L/240	L/360	L/120	L/240	L/360	L/120	L/240	L/360
3-5/8	362PDS125-15	0.0158	50	12	21' 6"	17' 1"	14' 11"	18' 4" f	14' 11"	13' 0"	15' 10" f	13' 7"	11' 10"
				16	19' 5" f	15' 6"	13' 7"	15' 10" f	13' 7"	11' 10"	13' 9" f	12' 4"	10' 7"
				24	15' 10" f	13' 7"	11' 10"	12' 11" f	11' 10"	10' 1"	11' 2" f	10' 7"	9' 0"
	362PDS125-18	0.0190	70	12	22' 0"	18' 2"	15' 8"	19' 3"	15' 10"	13' 8"	17' 6"	14' 5"	12' 5"
				16	20' 6"	16' 10"	14' 7"	17' 11"	14' 9"	12' 9"	16' 3"	13' 5"	11' 6"
				24	18' 4"	15' 1"	13' 0"	15' 11" f	13' 2"	11' 4"	13' 9" f	12' 0"	10' 1"
	362PDS125-30	0.0312	33	12	25' 8"	20' 5"	17' 10"	22' 5"	17' 10"	15' 7"	20' 5"	16' 2"	14' 2"
				16	23' 4"	18' 6"	16' 2"	20' 5"	16' 2"	14' 2"	18' 6"	14' 8"	12' 10"
				24	20' 5"	16' 2"	14' 2"	17' 10"	14' 2"	12' 3"	16' 2"	12' 10"	11' 0"
	362PDS125-33	0.0346	33	12	26' 7"	21' 2"	18' 5"	23' 3"	18' 5"	16' 1"	21' 2"	16' 9"	14' 8"
				16	24' 2"	19' 2"	16' 9"	21' 2"	16' 9"	14' 8"	19' 2"	15' 3"	13' 4"
				24	21' 2"	16' 9"	14' 8"	18' 5"	14' 8"	12' 10"	16' 9"	13' 4"	11' 6"
4	400PDS125-15	0.0158	50	12	22' 8"	18' 0"	15' 9"	19' 1" f	15' 9"	13' 9"	16' 6" f	14' 4"	12' 6"
				16	20' 3" f	16' 4"	14' 4"	16' 6" f	14' 4"	12' 6"	14' 4" f	13' 0"	11' 3"
				24	16' 6" f	14' 4"	12' 6"	13' 6" f	12' 6"	10' 8"	11' 8" f	11' 3"	9' 6"
	400PDS125-18	0.0190	70	12	22' 9"	18' 8"	16' 4"	19' 11"	16' 4"	14' 3"	18' 1"	14' 10"	13' 0"
				16	21' 4"	17' 7"	15' 4"	18' 8"	15' 4"	13' 5"	16' 11"	13' 11"	12' 2"
				24	19' 3"	15' 10"	13' 10"	16' 7" f	13' 10"	12' 1"	14' 4" f	12' 6"	10' 9"
	400PDS125-30	0.0312	33	12	27' 5"	21' 9"	19' 0"	24' 0"	19' 0"	16' 8"	21' 9"	17' 4"	15' 1"
				16	24' 11"	19' 10"	17' 4"	21' 9"	17' 4"	15' 1"	19' 10"	15' 9"	13' 9"
				24	21' 9"	17' 4"	15' 1"	19' 0"	15' 1"	13' 2"	17' 4"	13' 9"	11' 10"
	400PDS125-33	0.0346	33	12	27' 10"	22' 9"	20' 1"	24' 3"	19' 11"	17' 7"	22' 1"	18' 1"	15' 11"
				16	25' 3"	20' 8"	18' 3"	22' 1"	18' 1"	15' 11"	20' 1"	16' 5"	14' 6"
				24	22' 1"	18' 1"	15' 11"	19' 3"	15' 10"	13' 11"	17' 6"	14' 4"	12' 8"
6	600PDS125-15	0.0158	50	12	27' 10" f	24' 2"	21' 5"	22' 9" f	21' 1"	18' 8"	19' 8" f	19' 2"	17' 0"
				16	24' 1" f	21' 11"	19' 5"	19' 8" f	19' 2"	17' 0"	17' 1" f	17' 1" f	15' 5"
				24	19' 8" f	19' 2"	17' 0"	16' 1" f	16' 1" f	14' 9"	13' 11" f	13' 11" f	13' 4"
	600PDS125-18	0.0190	70	12	32' 1"	25' 6"	22' 3"	28' 1"	22' 3"	19' 5"	24' 4" f	20' 3"	17' 8"
				16	29' 10"	23' 8"	20' 8"	24' 10" f	20' 8"	18' 1"	21' 6" f	18' 9"	16' 5"
				24	25' 5" f	21' 1"	18' 5"	20' 9" f	18' 5"	16' 1"	18' 0" f	16' 9"	14' 6"
	600PDS125-30	0.0312	33	12	36' 7"	29' 1"	25' 5"	32' 0"	25' 5"	22' 2"	29' 1"	23' 1"	20' 2"
				16	33' 3"	26' 5"	23' 1"	29' 1"	23' 1"	20' 2"	26' 5"	20' 11"	18' 4"
				24	29' 1"	23' 1"	20' 2"	25' 5"	20' 2"	17' 7"	22' 6" f	18' 4"	
	600PDS125-33	0.0346	33	12	36' 8"	30' 1"	26' 6"	32' 0"	26' 3"	23' 2"	29' 1"	23' 10"	21' 0"
				16	33' 3"	27' 4"	24' 1"	29' 1"	23' 10"	21' 0"	26' 5"	21' 8"	19' 1"
				24	29' 1"	23' 10"	21' 0"	25' 5"	20' 10"	18' 4"	23' 1"	18' 11"	

## Limiting Wall Heights

### Non-Composite Limiting Heights Fully Braced

Depth (in)	Section	Design thickness (in)	Yield strength (ksi)	Spacing o.c. (in)	Lateral Load (psf)								
					5psf		7.5psf		10psf				
					L/120	L/240	L/360	L/120	L/240	L/360	L/120	L/240	L/360
1-5/8	162PDS125-15	0.0158	50	12	9' 2"	7' 4"	6' 4"	8' 0"	6' 4"	5' 7"	6' 11"	5' 9"	5' 1"
				16	8' 4"	6' 8"	5' 9"	6' 11"	5' 9"	5' 1"	6' 0"	5' 3"	4' 7"
				24	6' 11"	5' 9"	5' 1"	5' 8"	5' 1"	4' 5"	4' 11"	4' 7"	4' 0"
	162PDS125-18	0.0190	70	12	9' 9"	7' 9"	6' 9"	8' 6"	6' 9"	5' 11"	7' 9"	6' 2"	5' 4"
				16	8' 10"	7' 0"	6' 2"	7' 9"	6' 2"	5' 4"	7' 0"	5' 7"	4' 10"
				24	7' 9"	6' 2"	5' 4"	6' 9"	5' 4"	4' 8"	6' 2"	4' 10"	4' 3"
	162PDS125-30	0.0312	33	12	11' 10"	9' 5"	8' 3"	10' 4"	8' 3"	7' 2"	9' 5"	7' 6"	6' 6"
				16	10' 9"	8' 7"	7' 6"	9' 5"	7' 6"	6' 6"	8' 2"	6' 9"	5' 11"
				24	9' 5"	7' 6"	6' 6"	7' 8"	6' 6"	5' 8"	6' 8"	5' 11"	5' 2"
	162PDS125-33	0.0346	33	12	12' 3"	9' 9"	8' 6"	10' 8"	8' 6"	7' 5"	9' 9"	7' 9"	6' 9"
				16	11' 2"	8' 10"	7' 9"	9' 9"	7' 9"	6' 9"	8' 9"	7' 0"	6' 1"
				24	9' 9"	7' 9"	6' 9"	8' 3"	6' 9"	5' 11"	7' 2"	6' 1"	5' 4"
2-1/2	250PDS125-15	0.0158	50	12	12' 8"	10' 2"	8' 11"	10' 4"	8' 11"	7' 9"	8' 11"	8' 1"	7' 1"
				16	10' 11"	9' 3"	8' 1"	8' 11"	8' 1"	7' 1"	7' 9"	7' 4"	6' 5"
				24	8' 11"	8' 1"	7' 1"	7' 4"	7' 1"	6' 2"	6' 4"	6' 4"	5' 7"
	250PDS125-18	0.0190	70	12	13' 9"	10' 11"	9' 6"	12' 0"	9' 6"	8' 4"	10' 11"	8' 8"	7' 7"
				16	12' 6"	9' 11"	8' 8"	10' 11"	8' 8"	7' 7"	9' 11"	7' 10"	6' 10"
				24	10' 11"	8' 8"	7' 7"	9' 6"	7' 7"	6' 7"	8' 4"	6' 10"	6' 0"
	250PDS125-30	0.0312	33	12	16' 5"	13' 0"	11' 4"	14' 4"	11' 4"	9' 11"	12' 6"	10' 4"	9' 0"
				16	14' 11"	11' 10"	10' 4"	12' 6"	10' 4"	9' 0"	10' 10"	9' 5"	8' 2"
				24	12' 6"	10' 4"	9' 0"	10' 3"	9' 0"	7' 11"	8' 10"	8' 2"	7' 2"
	250PDS125-33	0.0346	33	12	16' 11"	13' 5"	11' 9"	14' 10"	11' 9"	10' 3"	13' 5"	10' 8"	9' 4"
				16	15' 5"	12' 3"	10' 8"	13' 5"	10' 8"	9' 4"	11' 7"	9' 8"	8' 6"
				24	13' 5"	10' 8"	9' 4"	10' 11"	9' 4"	8' 2"	9' 6"	8' 6"	7' 5"
3-5/8	362PDS125-15	0.0158	50	12	15' 0"	13' 7"	11' 10"	12' 3"	11' 10"	10' 4"	10' 7"	10' 7"	9' 5"
				16	13' 0"	12' 4"	10' 9"	10' 7"	10' 7"	9' 5"	9' 2"	9' 2"	8' 6"
				24	10' 7"	10' 7"	9' 5"	8' 8"	8' 8"	8' 3"	7' 6"	7' 6"	7' 5"
	362PDS125-18	0.0190	70	12	18' 4"	14' 6"	12' 8"	16' 0"	12' 8"	11' 1"	14' 5"	11' 6"	10' 1"
				16	16' 8"	13' 2"	11' 6"	14' 5"	11' 6"	10' 1"	12' 5"	10' 6"	9' 2"
				24	14' 5"	11' 6"	10' 1"	11' 9"	10' 1"	8' 10"	10' 2"	9' 2"	8' 0"
	362PDS125-30	0.0312	33	12	21' 2"	17' 4"	15' 2"	17' 3"	15' 2"	13' 3"	15' 0"	13' 9"	12' 0"
				16	18' 4"	15' 9"	13' 9"	15' 0"	13' 9"	12' 0"	12' 11"	12' 6"	10' 11"
				24	15' 0"	13' 9"	12' 0"	12' 3"	12' 0"	10' 6"	10' 7"	10' 7"	9' 6"
	362PDS125-33	0.0346	33	12	22' 7"	17' 11"	15' 8"	18' 9"	15' 8"	13' 8"	16' 3"	14' 3"	12' 5"
				16	19' 10"	16' 3"	14' 3"	16' 3"	14' 3"	12' 5"	14' 0"	12' 11"	11' 3"
				24	16' 3"	14' 3"	12' 5"	13' 3"	12' 5"	10' 10"	11' 6"	11' 3"	9' 10"

- Notes:
- Heights are based on AISI S100-16, North American Specification and AISI S220-15, North American Standard for Cold-Formed Steel Framing — Nonstructural Members, using steel properties alone.
  - Above listed Non-Composite Limiting Heights are applicable when the unbraced length is less than or equal to Lu.
  - Heights are limited by moment, deflection, shear, and web crippling (assuming 1" end reaction bearing).
  - \*Web stiffeners are required at bearing points.

See Interior Non-Structural Non-Composite Table Notes

## Limiting Wall Heights

### Non-Composite Limiting Heights Fully Braced

Depth (in)	Stud member	Design thickness (in)	Yield strength (ksi)	Spacing o.c. (in)	Lateral Load (psf)								
					L/120	L/240	L/360	L/120	L/240	L/360	L/120	L/240	L/360
4	400PDS125-15	0.0158	50	12	15' 9"	14' 6"	12' 8"	12' 11"	12' 8"	11' 1"	11' 2"	11' 2"	10' 1"
				16	13' 8"	13' 2"	11' 6"	11' 2"	11' 2"	10' 1"	9' 8"	9' 8"	9' 2"
				24	11' 2"	11' 2"	10' 1"	9' 1"	9' 1"	8' 9"	7' 11"	7' 11"	7' 11"
	400PDS125-18	0.0190	70	12	19' 7"	15' 6"	13' 7"	17' 1"	13' 7"	11' 10"	15' 4"	12' 4"	10' 9"
				16	17' 9"	14' 1"	12' 4"	15' 4"	12' 4"	10' 9"	13' 3"	11' 2"	9' 9"
				24	15' 4"	12' 4"	10' 9"	12' 6"	10' 9"	9' 5"	10' 10"	9' 9"	8' 7"
	400PDS125-30	0.0312	33	12	22' 4"	18' 8"	16' 4"	18' 3"	16' 4"	14' 3"	15' 9"	14' 10"	13' 0"
				16	19' 4"	17' 0"	14' 10"	15' 9"	14' 10"	13' 0"	13' 8"	13' 6"	11' 9"
				24	15' 9"	14' 10"	13' 0"	12' 11"	12' 11"	11' 4"	11' 2"	11' 2"	10' 3"
	400PDS125-33	0.0346	33	12	24' 2"	19' 4"	16' 11"	19' 9"	16' 11"	14' 9"	17' 1"	15' 4"	13' 5"
				16	21' 0"	17' 7"	15' 4"	17' 1"	15' 4"	13' 5"	14' 10"	13' 11"	12' 2"
				24	17' 1"	15' 4"	13' 5"	14' 0"	13' 5"	11' 9"	12' 1"	12' 1"	10' 8"
6	600PDS125-15	0.0158	50	12	19' 3"	19' 2"	16' 9"	15' 9"	15' 9"	14' 8"	11' 11"	11' 11"	11' 11"
				16	16' 8"	16' 8"	15' 3"	11' 11"	11' 11"	11' 11"	8' 11"	8' 11"	8' 11"
				24	11' 11"	11' 11"	11' 11"	7' 11"	7' 11"	7' 11"	6' 0"	6' 0"	6' 0"
	600PDS125-18	0.0190	70	12	26' 0"	20' 8"	18' 0"	21' 11"	18' 0"	15' 9"	19' 0"	16' 4"	14' 4"
				16	23' 3"	18' 9"	16' 4"	19' 0"	16' 4"	14' 4"	15' 7"	14' 11"	13' 0"
				24	19' 0"	16' 4"	14' 4"	13' 10"	13' 10"	12' 6"	10' 5"	10' 5"	10' 5"
	600PDS125-30	0.0312	33	12	28' 4"	25' 7"	22' 4"	23' 2"	22' 4"	19' 7"	20' 1"	20' 1"	17' 9"
				16	24' 7"	23' 3"	20' 4"	20' 1"	20' 1"	17' 9"	17' 4"	17' 4"	16' 2"
				24	20' 1"	20' 1"	17' 9"	16' 4"	16' 4"	15' 6"	14' 2"	14' 2"	14' 1"
	600PDS125-33	0.0346	33	12	30' 7"	26' 7"	23' 2"	25' 0"	23' 2"	20' 3"	21' 8"	21' 1"	18' 5"
				16	26' 6"	24' 1"	21' 1"	21' 8"	21' 1"	18' 5"	18' 9"	18' 9"	16' 9"
				24	21' 8"	21' 1"	18' 5"	17' 8"	17' 8"	16' 1"	15' 4"	15' 4"	14' 7"

Notes:

- Heights are based on AISI S100-16, North American Specification and AISI S220-15, North American Standard for Cold-Formed Steel Framing — Nonstructural Members, using steel properties alone.
- Above listed Non-Composite Limiting Heights are applicable when the unbraced length is less than or equal to Lu.
- Heights are limited by moment, deflection, shear, and web crippling (assuming 1" end reaction bearing).
- \*Web stiffeners are required at bearing points.

See Interior Non-Structural Non-Composite Table Notes

## Limiting Wall Heights

### Non-Composite Limiting Heights Braced At 48" o.c.

Depth (in)	Section	Design thickness (in)	Yield strength (ksi)	Spacing o.c. (in)	Lateral Load (psf)								
					5psf			7.5psf			10psf		
					L/120	L/240	L/360	L/120	L/240	L/360	L/120	L/240	L/360
1-5/8	162PDS125-15	0.0158	50	12	8' 1"	7' 4"	6' 4"	6' 7"	6' 4"	5' 7"	5' 9"	5' 9"	5' 1"
		0.0158	50	16	7' 0"	6' 8"	5' 9"	5' 9"	5' 9"	5' 1"	4' 11"	4' 11"	4' 7"
		0.0158	50	24	5' 9"	5' 9"	5' 1"	4' 8"	4' 8"	4' 5"	4' 0"	4' 0"	4' 0"
	162PDS125-18	0.0190	70	12	9' 6"	7' 9"	6' 9"	7' 9"	6' 9"	5' 11"	6' 9"	6' 2"	5' 4"
		0.0190	70	16	8' 3"	7' 0"	6' 2"	6' 9"	6' 2"	5' 4"	5' 10"	5' 7"	4' 10"
		0.0190	70	24	6' 9"	6' 2"	5' 4"	5' 6"	5' 4"	4' 8"	4' 9"	4' 9"	4' 3"
	162PDS125-30	0.0312	33	12	11' 10"	9' 5"	8' 3"	10' 3"	8' 3"	7' 2"	8' 11"	7' 6"	6' 6"
		0.0312	33	16	10' 9"	8' 7"	7' 6"	8' 11"	7' 6"	6' 6"	7' 8"	6' 9"	5' 11"
		0.0312	33	24	8' 11"	7' 6"	6' 6"	7' 3"	6' 6"	5' 8"	6' 3"	5' 11"	5' 2"
	162PDS125-33	0.0346	33	12	12' 3"	9' 9"	8' 6"	10' 8"	8' 6"	7' 5"	9' 5"	7' 9"	6' 9"
		0.0346	33	16	11' 2"	8' 10"	7' 9"	9' 5"	7' 9"	6' 9"	8' 2"	7' 0"	6' 1"
		0.0346	33	24	9' 5"	7' 9"	6' 9"	7' 8"	6' 9"	5' 11"	6' 8"	6' 1"	5' 4"
2-1/2	250PDS125-15	0.0158	50	12	10' 5"	10' 2"	8' 11"	8' 6"	8' 6"	7' 9"	7' 4"	7' 4"	7' 1"
		0.0158	50	16	9' 0"	9' 0"	8' 1"	7' 4"	7' 4"	7' 1"	6' 5"	6' 5"	6' 5"
		0.0158	50	24	7' 4"	7' 4"	7' 1"	6' 0"	6' 0"	6' 0"	5' 3"	5' 3"	5' 3"
	250PDS125-18	0.0190	70	12	13' 5"	10' 11"	9' 6"	10' 11"	9' 6"	8' 4"	9' 6"	8' 8"	7' 7"
		0.0190	70	16	11' 7"	9' 11"	8' 8"	9' 6"	8' 8"	7' 7"	8' 3"	7' 10"	6' 10"
		0.0190	70	24	9' 6"	8' 8"	7' 7"	7' 9"	7' 7"	6' 7"	6' 8"	6' 8"	6' 0"
	250PDS125-30	0.0312	33	12	16' 5"	13' 0"	11' 4"	13' 8"	11' 4"	9' 11"	11' 10"	10' 4"	9' 0"
		0.0312	33	16	14' 6"	11' 10"	10' 4"	11' 10"	10' 4"	9' 0"	10' 3"	9' 5"	8' 2"
		0.0312	33	24	11' 10"	10' 4"	9' 0"	9' 8"	9' 0"	7' 11"	8' 4"	8' 2"	7' 2"
	250PDS125-33	0.0346	33	12	16' 11"	13' 5"	11' 9"	14' 4"	11' 9"	10' 3"	12' 5"	10' 8"	9' 4"
		0.0346	33	16	15' 3"	12' 3"	10' 8"	12' 5"	10' 8"	9' 4"	10' 9"	9' 8"	8' 6"
		0.0346	33	24	12' 5"	10' 8"	9' 4"	10' 2"	9' 4"	8' 2"	8' 10"	8' 6"	7' 5"
3-5/8	362PDS125-15	0.0158	50	12	12' 5"	12' 5"	11' 10"	10' 1"	10' 1"	10' 1"	8' 9"	8' 9"	8' 9"
		0.0158	50	16	10' 9"	10' 9"	10' 9"	8' 9"	8' 9"	8' 9"	7' 7"	7' 7"	7' 7"
		0.0158	50	24	8' 9"	8' 9"	8' 9"	7' 2"	7' 2"	7' 2"	6' 2"	6' 2"	6' 2"
	362PDS125-18	0.0190	70	12	15' 2"	14' 6"	12' 8"	12' 5"	12' 5"	11' 1"	10' 9"	10' 9"	10' 1"
		0.0190	70	16	13' 2"	13' 2"	11' 6"	10' 9"	10' 9"	10' 1"	9' 4"	9' 4"	9' 2"
		0.0190	70	24	10' 9"	10' 9"	10' 1"	8' 9"	8' 9"	8' 9"	7' 7"	7' 7"	7' 7"
	362PDS125-30	0.0312	33	12	20' 0"	17' 4"	15' 2"	16' 4"	15' 2"	13' 3"	14' 1"	13' 9"	12' 0"
		0.0312	33	16	17' 3"	15' 9"	13' 9"	14' 1"	13' 9"	12' 0"	12' 3"	12' 3"	10' 11"
		0.0312	33	24	14' 1"	13' 9"	12' 0"	11' 6"	11' 6"	10' 6"	10' 0"	10' 0"	9' 6"
	362PDS125-33	0.0346	33	12	21' 3"	17' 11"	15' 8"	17' 4"	15' 8"	13' 8"	15' 0"	14' 3"	12' 5"
		0.0346	33	16	18' 5"	16' 3"	14' 3"	15' 0"	14' 3"	12' 5"	13' 0"	12' 11"	11' 3"
		0.0346	33	24	15' 0"	14' 3"	12' 5"	12' 3"	12' 3"	10' 10"	10' 8"	10' 8"	9' 10"

Notes:

- Heights are based on AISI S100-16, North American Specification and AISI S220-15, North American Standard for Cold-Formed Steel Framing — Nonstructural Members, using steel properties alone.
- Above listed Non-Composite Limiting Heights are applicable when the unbraced length is less than or equal to  $L_u$ .
- Heights are limited by moment, deflection, shear, and web crippling (assuming 1" end reaction bearing).
- \*Web stiffeners are required at bearing points.

See Interior Non-Structural Non-Composite Table Notes

## Limiting Wall Heights

### Non-Composite Limiting Heights Braced At 48" o.c.

Depth (in)	Section	Design thickness (in)	Yield strength (ksi)	Spacing o.c. (in)	Lateral Load (psf)								
					5psf			7.5psf			10psf		
					L/120	L/240	L/360	L/120	L/240	L/360	L/120	L/240	L/360
4	400PDS125-15	0.0158	50	12	13' 0"	13' 0"	12' 8"	10' 8"	10' 8"	10' 8"	9' 2"	9' 2"	9' 2"
		0.0158	50	16	11' 3"	11' 3"	11' 3"	9' 2"	9' 2"	9' 2"	8' 0"	8' 0"	8' 0"
		0.0158	50	24	9' 2"	9' 2"	9' 2"	7' 6"	7' 6"	7' 6"	6' 6"	6' 6"	6' 6"
	400PDS125-18	0.0190	70	12	16' 3"	15' 6"	13' 7"	13' 3"	13' 3"	11' 10"	11' 6"	11' 6"	10' 9"
		0.0190	70	16	14' 1"	14' 1"	12' 4"	11' 6"	11' 6"	10' 9"	9' 11"	9' 11"	9' 9"
		0.0190	70	24	11' 6"	11' 6"	10' 9"	9' 4"	9' 4"	9' 4"	8' 1"	8' 1"	8' 1"
	400PDS125-30	0.0312	33	12	21' 1"	18' 8"	16' 4"	17' 2"	16' 4"	14' 3"	14' 11"	14' 10"	13' 0"
		0.0312	33	16	18' 3"	17' 0"	14' 10"	14' 11"	14' 10"	13' 0"	12' 11"	12' 11"	11' 9"
		0.0312	33	24	14' 11"	14' 10"	13' 0"	12' 2"	12' 2"	11' 4"	10' 6"	10' 6"	10' 3"
	400PDS125-33	0.0346	33	12	22' 5"	19' 4"	16' 11"	18' 4"	16' 11"	14' 9"	15' 10"	15' 4"	13' 5"
		0.0346	33	16	19' 5"	17' 7"	15' 4"	15' 10"	15' 4"	13' 5"	13' 9"	13' 9"	12' 2"
		0.0346	33	24	15' 10"	15' 4"	13' 5"	13' 0"	13' 0"	11' 9"	11' 3"	11' 3"	10' 8"
6	600PDS125-15	0.0158	50	12	15' 11"	15' 11"	15' 11"	13' 0"	13' 0"	13' 0"	11' 3"	11' 3"	11' 3"
		0.0158	50	16	13' 9"	13' 9"	13' 9"	11' 3"	11' 3"	11' 3"	8' 11"	8' 11"	8' 11"
		0.0158	50	24	11' 3"	11' 3"	11' 3"	7' 11"	7' 11"	7' 11"	6' 0"	6' 0"	6' 0"
	600PDS125-18	0.0190	70	12	20' 10"	20' 8"	18' 0"	17' 0"	17' 0"	15' 9"	14' 8"	14' 8"	14' 4"
		0.0190	70	16	18' 0"	18' 0"	16' 4"	14' 8"	14' 8"	14' 4"	12' 9"	12' 9"	12' 9"
		0.0190	70	24	14' 8"	14' 8"	14' 4"	12' 0"	12' 0"	12' 0"	10' 5"	10' 5"	10' 5"
	600PDS125-30	0.0312	33	12	26' 9"	25' 7"	22' 4"	21' 10"	21' 10"	19' 7"	18' 11"	18' 11"	17' 9"
		0.0312	33	16	23' 2"	23' 2"	20' 4"	18' 11"	18' 11"	17' 9"	16' 5"	16' 5"	16' 2"
		0.0312	33	24	18' 11"	18' 11"	17' 9"	15' 5"	15' 5"	15' 5"	13' 5"	13' 5"	13' 5"
	600PDS125-33	0.0346	33	12	28' 4"	26' 7"	23' 2"	23' 2"	23' 2"	20' 3"	20' 1"	20' 1"	18' 5"
		0.0346	33	16	24' 7"	24' 1"	21' 1"	20' 1"	20' 1"	18' 5"	17' 5"	17' 5"	16' 9"
		0.0346	33	24	20' 1"	20' 1"	18' 5"	16' 5"	16' 5"	16' 1"	14' 2"	14' 2"	14' 2"

Notes:

- Heights are based on AISI S100-16, North American Specification and AISI S220-15, North American Standard for Cold-Formed Steel Framing — Nonstructural Members, using steel properties alone.
- Above listed Non-Composite Limiting Heights are applicable when the unbraced length is less than or equal to Lu.
- Heights are limited by moment, deflection, shear, and web crippling (assuming 1" end reaction bearing).
- \*Web stiffeners are required at bearing points.

See Interior Non-Structural Non-Composite Table Notes

## Section Properties

### Section Properties Table Notes

1. Section properties were determined in accordance with AISI S100-16/2-20, North American Specification for Design of Cold-Formed Steel Structural Members.
2. Effective properties incorporate the strength increase from the cold work of forming as applicable per AISI A7.2.
3. Tabulated gross properties including torsional properties are based on full-unreduced cross section of the studs, away from punchouts.
4. For deflection calculations, use the effective moment of inertia.
5. Allowable moment includes cold-work of forming.
6. Web depth for track sections is equal to the nominal height plus 2 times the design thickness plus the bend radius. Hems on non-structural rack sections are ignored.
7. Allowable moment is taken as the lowest value based on local or distortional buckling. Distortional buckling strength is based on a  $k\text{-}\phi = 0$ .

### ProTRAK® Allowable Lateral Loads and Wall Heights

Deflection Track System	2" Leg Track with 1/2" Gap		2-1/2" Leg Track with 3/4" Gap		3" Leg Track with 1" Gap	
	Allowable Load (LBS)	Limiting Wall Height	Allowable Load (LBS)	Limiting Wall Height	Allowable Load (LBS)	Limiting Wall Height
ProTRAK 25	36	10' 8"	24	7' 2"	18	5' 4"
ProTRAK 20	52	15' 6"	34	10' 4"	26	7' 9"
ProTRAK 30MIL	92	27' 6"	61	18' 4"	46	13' 9"
ProTRAK 33MIL	113	33' 10"	75	22' 7"	56	16' 11"

Notes:

- Limiting wall heights are based on studs spaced at 16" o.c. and an interior lateral load of 5psf.
- Stud members must be analyzed independently of the track system. Use [www.iProSTUD.com](http://www.iProSTUD.com) to check limiting wall heights for ProSTUD members.
- Stud failure modes relating to the deflection track connection (shear, web crippling, etc.) must be checked separately.

## ProSTUD 1-5/8" Stud Chase Sound Assemblies

Two parallel rows

Gypsum Type	Side A	Side B	Insulation Type	Stud spacing	STC Rating	Test Report	Partition Type
					ProSTUD 25 (15mil)		
5/8" Type X	1 layer	1 layer	R-13" unfaced	24"	55	TL09-590	1 Similar
5/8" Type X	1 layer	2 layers	R-13" unfaced	24"	59	TL09-591	1 Similar
5/8" Type X	2 layers	2 layers	R-13" unfaced	24"	61	TL09-592	1

## ProSTUD 2-1/2" Stud Chase Sound Assemblies

Staggered in opposite walls

Gypsum Type	Side A	Side B	Insulation Type	Stud spacing	STC Rating	Test Report	Partition Type
					ProSTUD 25 (15mil)		
5/8" Type X	1 layer	1 layer	R-13" unfaced	24"	58	TL09-593	2 Similar
5/8" Type X	1 layer	2 layers	R-13" unfaced	24"	63	TL09-594	2 Similar
5/8" Type X	2 layers	2 layers	R-13" unfaced	24"	65	TL09-595	2

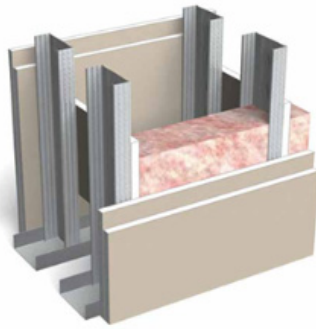

Partition Type 1

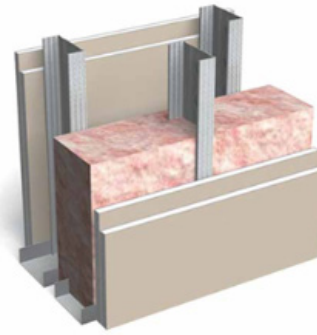

Partition Type 2

**Notes:**

Sound Assemblies are certified by Western Electro-Acoustic Laboratories.  
 NVLAP Accredited for ASTM E90 & E413, ISO Certified.  
 Values are the same for R-11 insulation.

Complies with AISI S100-16 • AISI S220-15 • IBC 2018

## ProSTUD 3-5/8" Stud Sound Assemblies

Gypsum Type	Side A	Side B	Insulation Type	Stud spacing	STC Rating	Test Report	Partition Type
					ProSTUD 25 (15mil)		
5/8" Type X	1 layer	1 layer	-	24"	43	TL09-539	Fig.1
5/8" Type X	1 layer	1 layer	R-13" unfaced	24"	48	TL09-540	Fig.2
5/8" Type X	1 layer	2 layer	R-13" unfaced	24"	49	TL09-167	Fig.3
5/8" Type X	2 layer	2 layer	R-13" unfaced	24"	54	TL09-538	Fig.4

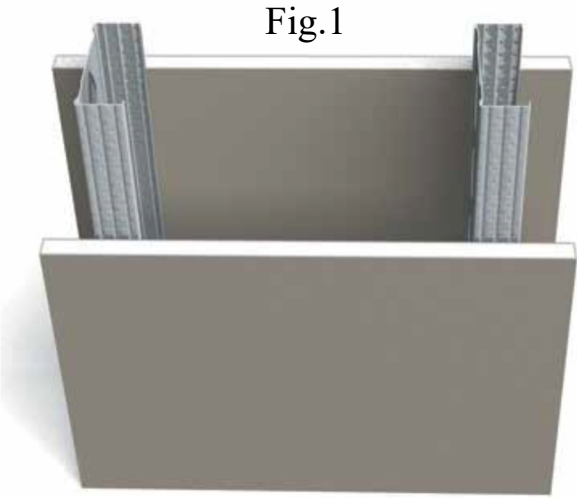

Fig.1

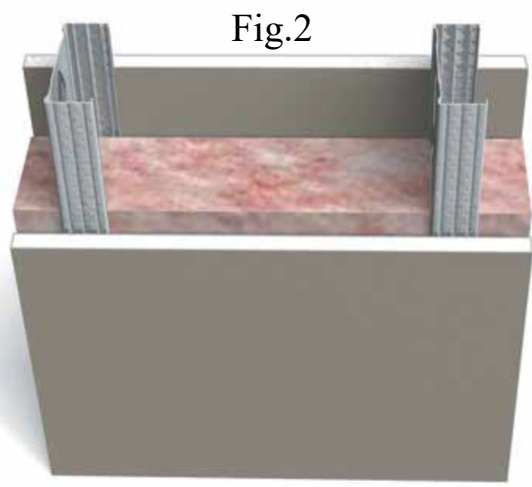

Fig.2



Fig.3

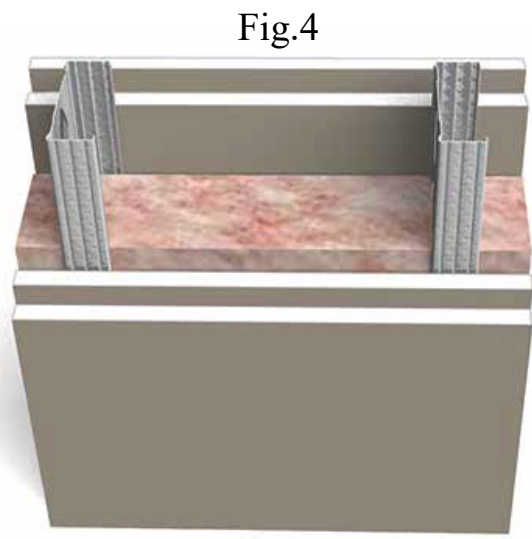

Fig.4

Notes:  
 Sound Assemblies are certified by Western Electro-Acoustic Laboratories.  
 NVLAP Accredited for ASTM E90 & E413, ISO Certified.  
 Values are the same for R-11 insulation.

Complies with AISI S100-16 • AISI S220-15 • IBC 2018

## ProSTUD® Allowable Ceiling Spans

### Deflection Limit L/240

Member	Fy (ksi)	4psf						6psf					
		Unsupported joist spacing (in) o.c.			Mid-span joist spacing (in) o.c.			Unsupported joist spacing (in) o.c.			Mid-span joist spacing (in) o.c.		
		12	16	24	12	16	24	12	16	24	12	16	24
162PDS125-15	50	7' 3"	6' 8"	5' 11"	7' 10"	7' 2"	6' 3"	6' 5"	5' 11"	5' 3"	6' 10"	6' 3"	5' 5"
250PDS125-15	50	8' 4"	7' 8"	6' 11"	10' 11"	9' 11"	8' 8"	7' 5"	6' 11"	6' 2"	9' 7"	8' 8"	7' 7"
362PDS125-15	50	9' 2"	8' 6"	7' 7"	12' 9"	11' 8"	10' 3"	8' 3"	7' 7"	6' 9"	11' 3"	10' 3"	8' 11" e
400PDS125-15	50	9' 5"	8' 9"	7' 10"	13' 1"	12' 0"	10' 7" e	8' 6"	7' 10"	6' 11" e	11' 7" e	10' 7" e	9' 3" e
600PDS125-15	50	10' 8"	9' 10"	8' 10"	15' 0"	13' 9"	12' 2"	9' 6"	8' 10"	7' 11"	13' 3"	12' 2"	9' 11" e
162PDS125-18	70	7' 10"	7' 3"	6' 6"	8' 4"	7' 7"	6' 8"	7' 1"	6' 6"	5' 9"	7' 4"	6' 8"	5' 10"
250PDS125-18	70	9' 0"	8' 5"	7' 7"	11' 9"	10' 8"	9' 4"	8' 3"	7' 7"	6' 9"	10' 3"	9' 4"	8' 2"
362PDS125-18	70	9' 11"	9' 2"	8' 3"	14' 1"	12' 11"	11' 6"	8' 11"	8' 3"	7' 5"	12' 6"	11' 6"	10' 2"
400PDS125-18	70	10' 2"	9' 5"	8' 6"	14' 6"	13' 4"	11' 10"	9' 2"	8' 6"	7' 8"	12' 11"	11' 10"	10' 6"
600PDS125-18	70	11' 10"	10' 11"	9' 10"	16' 10"	15' 6"	13' 10"	10' 7"	9' 10"	8' 10"	15' 0"	13' 10"	12' 3"
162PDS125-30	33	9' 4"	8' 7"	7' 8"	9' 10"	9' 0"	9' 4"	7' 10"	7' 8"	6' 10"	8' 7"	7' 10"	6' 10"
250PDS125-30	33	10' 4"	9' 7"	8' 6"	13' 8"	12' 5"	10' 10"	9' 3"	8' 6"	7' 8"	11' 11"	10' 10"	9' 6"
362PDS125-30	33	11' 3"	10' 5"	9' 4"	16' 2"	15' 0"	13' 6"	10' 1"	9' 4"	8' 5"	14' 7"	13' 6"	12' 0"
400PDS125-30	33	11' 7"	10' 9"	9' 8"	16' 8"	15' 6"	13' 11"	10' 5"	9' 8"	8' 8"	15' 0"	13' 11"	12' 5"
600PDS125-30	33	13' 1"	12' 2"	10' 11"	18' 11"	17' 6"	15' 8"	11' 9"	10' 11"	9' 10"	17' 0"	15' 8"	14' 1"
162PDS125-33	33	9' 9"	9' 0"	8' 0"	10' 4"	9' 4"	8' 2"	8' 8"	8' 0"	7' 1"	9' 0"	8' 2"	7' 2"
250PDS125-33	33	10' 9"	9' 11"	8' 10"	14' 3"	12' 11"	11' 3"	9' 7"	8' 10"	7' 11"	12' 5"	11' 3"	9' 10"
362PDS125-33	33	11' 8"	10' 9"	9' 8"	16' 8"	15' 5"	13' 11"	10' 5"	9' 8"	8' 8"	15' 0"	13' 11"	12' 6"
400PDS125-33	33	12' 0"	11' 1"	9' 11"	17' 2"	15' 11"	14' 4"	10' 9"	9' 11"	8' 11"	15' 5"	14' 4"	12' 10"
600PDS125-33	33	13' 6"	12' 6"	11' 3"	19' 6"	18' 1"	16' 3"	12' 2"	11' 3"	10' 1"	17' 6"	16' 3"	14' 7"

### Deflection Limit L/360

Member	Fy (ksi)	4psf						6psf					
		Unsupported joist spacing (in) o.c.			Mid-span joist spacing (in) o.c.			Unsupported joist spacing (in) o.c.			Mid-span joist spacing (in) o.c.		
		12	16	24	12	16	24	12	16	24	12	16	24
162PDS125-15	50	6' 10"	6' 3"	5' 5"	6' 10"	6' 3"	5' 5"	6' 0"	5' 5"	4' 9"	6' 0"	5' 5"	4' 9"
250PDS125-15	50	8' 4"	7' 8"	6' 11"	9' 7"	8' 8"	7' 7"	7' 5"	6' 11"	6' 2"	8' 4"	7' 7"	6' 8"
362PDS125-15	50	9' 2"	8' 6"	7' 7"	12' 9"	11' 7"	10' 1"	8' 3"	7' 7"	6' 9"	11' 2"	10' 1"	8' 10" e
400PDS125-15	50	9' 5"	8' 9"	7' 10"	13' 1"	12' 0"	10' 7" e	8' 6"	7' 10"	6' 11" e	11' 7" e	10' 7" e	9' 3" e
600PDS125-15	50	10' 8"	9' 10"	8' 10"	15' 0"	13' 9"	12' 2"	9' 6"	8' 10"	7' 11"	13' 3"	12' 2"	9' 11" e
162PDS125-18	70	7' 4"	6' 8"	5' 10"	7' 4"	6' 8"	5' 10"	6' 5"	5' 10"	5' 1"	6' 5"	5' 10"	5' 1"
250PDS125-18	70	9' 0"	8' 5"	7' 7"	10' 3"	9' 4"	8' 2"	7' 7"	6' 9"	6' 10"	9' 0"	8' 2"	7' 2"
362PDS125-18	70	9' 11"	9' 2"	8' 3"	13' 9"	12' 6"	10' 11"	8' 11"	8' 3"	7' 5"	12' 0"	10' 11"	9' 6"
400PDS125-18	70	10' 2"	9' 5"	8' 6"	14' 6"	13' 4"	11' 8"	9' 2"	8' 6"	7' 8"	12' 10"	11' 8"	10' 2"
600PDS125-18	70	11' 10"	10' 11"	9' 10"	16' 10"	15' 6"	13' 10"	10' 7"	9' 10"	8' 10"	15' 0"	13' 10"	12' 3"
162PDS125-30	33	8' 7"	7' 10"	6' 10"	8' 7"	7' 10"	6' 10"	7' 6"	6' 10"	6' 0"	7' 6"	6' 10"	6' 0"
250PDS125-30	33	10' 4"	9' 7"	8' 6"	11' 11"	10' 10"	9' 6"	9' 3"	8' 6"	7' 8"	10' 5"	9' 6"	8' 3"
362PDS125-30	33	11' 3"	10' 5"	9' 4"	15' 11"	14' 6"	12' 8"	10' 1"	9' 4"	8' 5"	13' 11"	12' 8"	11' 1"
400PDS125-30	33	11' 7"	10' 9"	9' 8"	16' 8"	15' 6"	13' 9"	10' 5"	9' 8"	8' 8"	15' 0"	13' 9"	12' 0"
600PDS125-30	33	13' 1"	12' 2"	10' 11"	17' 6"	15' 8"	13' 9"	11' 9"	10' 11"	9' 10"	17' 0"	15' 8"	14' 1"
162PDS125-33	33	9' 0"	8' 2"	7' 2"	9' 0"	8' 2"	7' 2"	7' 10"	7' 2"	6' 3"	7' 10"	7' 2"	6' 3"
250PDS125-33	33	10' 9"	9' 11"	8' 10"	12' 5"	11' 3"	9' 10"	9' 7"	8' 10"	7' 11"	10' 10"	9' 10"	8' 7"
362PDS125-33	33	11' 8"	10' 9"	9' 8"	16' 6"	15' 0"	13' 2"	10' 5"	9' 8"	8' 8"	14' 5"	13' 2"	11' 6"
400PDS125-33	33	12' 0"	11' 1"	9' 11"	17' 2"	15' 11"	14' 3"	10' 9"	9' 11"	8' 11"	15' 5"	14' 3"	12' 5"
600PDS125-33	33	13' 6"	12' 6"	11' 3"	19' 6"	18' 1"	16' 3"	12' 2"	11' 3"	10' 1"	17' 6"	16' 3"	14' 7"

#### Notes:

- For unbraced sections, allowable moment is based on AISI S100-16/2-20 Specification Section C3.1.2 with weak axis and torsional unbraced length assumed to be the listed span (completely unbraced). For mid-span braced sections, allowable moment based on 2016 AISI Specification Section C3.1.2 with weak axis and torsional unbraced length assumed to be one-half of the listed span (bracing at mid-span).
- Web crippling calculation based on bearing length = 1 inch.
- Web crippling and shear capacity have not been reduced for punchouts. If web punchouts occur near support members must be checked for reduced shear and web crippling in accordance with the AISI S100-16/2-20 Specification.
- Values are for simple span conditions.
- Web stiffeners required at support.

## Allowable Screw Design Values

Member Designation	Thickness (mils)	Design Thickness (in)	Yield (ksi)	Ultimate	#6 Screw (.138" Dia., 5/16" Head)				#8 Screw (.164" Dia., 5/16" Head)				#6 Screw (.190" Dia., 0.34" Head)			
					Shear, lbs	1-Side	2-Side	Pullout, lbs	Shear, lbs	1-Side	2-Side	Pullout, lbs	Shear, lbs	1-Side	2-Side	Pullout, lbs
PDS125-15	15	0.0158	50	50	52	62	123	31	56	62	123	37	61	67	134	43
PDS125-18	18	0.0190	70	70	95	104	208	52	104	104	208	62	112	113	226	72
PDS125-19	19	0.0200	65	65	96	102	203	51	104	102	203	60	112	111	221	70
PDS125-30	30	0.0312	33	33	95	80	161	40	103	80	161	48	111	88	175	55
PDS125-33	33	0.0346	33	45	151	122	243	61	164	122	243	72	177	132	265	84

**Notes:**

- Allowable screw connection capacities are based on Section J4 of the AISI S100 Specification.
- When connecting materials of different steel thicknesses or tensile strengths, use the lowest values. Tabulated values assume two sheets of equal thickness are connected.
- Screw shear and tension capacities were developed using published screw manufacturer data and evaluation reports available at the time of publication.
- Screw capacities are based on Allowable Strength Design (ASD) and include a safety factor of 3.0.
- When multiple fasteners are used, screws are assumed to have a center-to-center spacing of at least three times the nominal diameter (d).
- Screws are assumed to have a center-of-screw to edge-of-steel dimension of at least 1-1/2 times the nominal diameter (d) of the screw.
- Tension capacity is based on the lesser of pullout capacity in sheet closest to screw tip, or pullover capacity for sheet closest to screw head (using head diameter).
- Screw capacities are governed by a conservative estimate of screw capacity, not by sheet steel failure.
- For higher screw capacities, especially for screw strength, use specific screws from specific manufacturer. See manufacturer's data for specific allowable values and installation instructions.

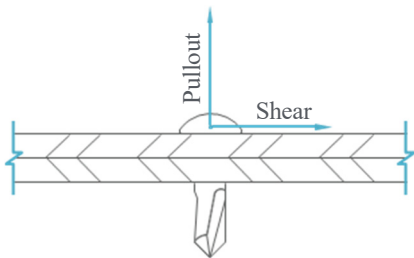

Pullout / Shear

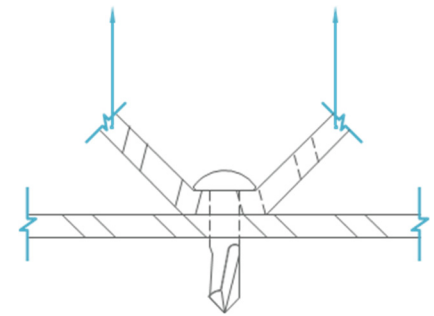
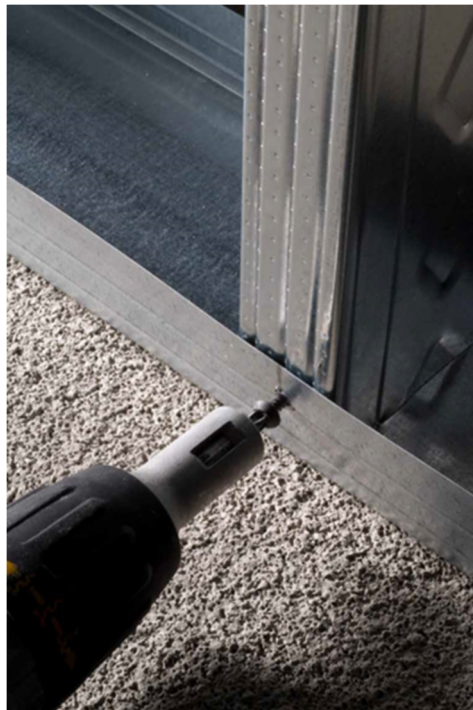

2-Sided Pullover

Complies with IBC 2021 • AISI S100 • AISI S220

## ProSTUD Single Stud Wall-Fire Assemblies<sup>A</sup>

UL design no.	Hourly Rating	ProSTUD minimum thickness	ProSTUD minimum depth
U403	2	ProSTUD 20 (18mil)	3-5/8"
U407	1/2 or 1	ProSTUD 25 (15mil)	3-5/8"
U408	2	ProSTUD 20 (18mil)	3-5/8"
U411	2	ProSTUD 25 (15mil)	2-1/2"
U412	2	ProSTUD 25 (15mil)	1-5/8"
U419	1,2,3, or 4	ProSTUD 25 (15mil)	(See Table 1 Next Page)
U421	2	ProSTUD 25 (15mil)	3-5/8"
U431	4	ProSTUD 20 (18mil)	3-5/8"
U435	3 or 4	ProSTUD 25 (15mil)	1-5/8"
U442*	1	ProSTUD 33MIL	2-1/2"
U450	1 or 3	ProSTUD 20 (18mil)	3-5/8"
U451	1	ProSTUD 20 (18mil)	2-1/2"
U454	2	ProSTUD 20 (18mil)	2-1/2"
U463	3 or 4	ProSTUD 20 (18mil)	1-5/8"
U465	1	ProSTUD 20 (18mil)	3-5/8"
U471	1-1/2	ProSTUD 20 (18mil)	3-5/8"
U475	1,2, or 3	ProSTUD 20 (18mil)	3-5/8"
U478	3	ProSTUD 20 (18mil)	1-5/8"
U484*	2	ProSTUD 33MIL	2-1/2"
U488*	1	ProSTUD 33MIL	2-1/2"
U490	4	ProSTUD 20 (18mil)	2-1/2"
U491	2	ProSTUD 20 (18mil)	3-5/8"
U494	1	ProSTUD 20 (18mil)	2-1/2"
U495	1 or 2	ProSTUD 20 (18mil)	3-5/8"
U496	1	ProSTUD 20 (18mil)	1-5/8"

Notes:

<sup>A</sup>See UL listing for detailed requirements of construction of tested assembly.

\*ProSTUD meets or exceeds the description of the generic stud/track listed in the UL assembly

Complies with AISI S100-16 • AISI S220 • IBC 2018



## ProSTUD Single Stud Wall-Fire Assemblies<sup>A</sup>

UL design no.	Hourly Rating	ProSTUD minimum thickness	ProSTUD minimum depth
V410	2	ProSTUD 20 (18mil)	1-5/8"
V412	2	ProSTUD 20 (18mil)	3-5/8"
V416	1	ProSTUD 20 (18mil)	3-5/8"
V417	1	ProSTUD 20 (18mil)	3-5/8"
V418	2	ProSTUD 20 (18mil)	1-5/8"
V419	2	ProSTUD 20 (18mil)	2-1/2"
V425	1	ProSTUD 20 (18mil)	2-1/2"
V435	1	ProSTUD 20 (18mil)	3-5/8"
V438	1,2,3, or 4	ProSTUD 25 (15mil)	(See Table 1 Next Page)
V443	4	ProSTUD 20 (18mil)	3-5/8"
V444	1	ProSTUD 20 (18mil)	3-5/8"
V448	1	ProSTUD 20 (18mil)	3-5/8"
V449	2	ProSTUD 20 (18mil)	3-5/8"
V450	1	ProSTUD 25 (15mil)	3-5/8"
V450	2	ProSTUD 25 (15mil)	2-1/2"
V452	1 or 2	ProSTUD 20 (18mil)	3-5/8"
V453*	1-1/2	ProSTUD 33MIL	6"
V461*	1	ProSTUD 33MIL	3-5/8"
V476	1 or 3	ProSTUD 20 (18mil)	3-5/8"
V477	1,2,3, or 4	ProSTUD 25 (15mil)	(See Table 1 Next Page)
V487	2	ProSTUD 20 (18mil)	1-5/8"
V489	1,2,3, or 4	ProSTUD 25 (15mil)	(See Table 1 Next Page)
V498	1,2,3, or 4	ProSTUD 25 (15mil)	(See Table 1 Next Page)
W411	1/2 or 1	ProSTUD 25 (15mil)	3-5/8"
W415	1 or 2	ProSTUD 20 (18mil)	2-1/2"
W424	1	ProSTUD 25 (15mil)	3-5/8"

Notes:

<sup>A</sup>See UL listing for detailed requirements of construction of tested assembly.

\*ProSTUD meets or exceeds the description of the generic stud/track listed in the UL assembly

Complies with AISI S100-16 • AISI S220 • IBC 2018



## ProSTUD Chase or Double Stud-Fire Assemblies<sup>A</sup>

UL design no.	Hourly Rating	ProSTUD minimum thickness	ProSTUD minimum depth
V420	2	ProSTUD 25 (15mil)	1-5/8"
V436	1,2, or 3	ProSTUD 20 (18mil)	1-5/8"
V444	2	ProSTUD 25 (15mil)	1-5/8"
V445*	1	ProSTUD 33 (33mil)	1-5/8"
U466	1	ProSTUD 20 (18mil)	2-1/2"
U493	2	ProSTUD 25 (15mil)	2-1/2"
V437	1	ProSTUD 20 (18mil)	1-5/8"

UL design no.	Hourly Rating	ProSTUD minimum thickness	ProSTUD minimum depth
V420	2	ProSTUD 25 (15mil)	1-5/8"
V436	1	ProSTUD 25 (15mil)	3-5/8"
V444	1	ProSTUD 33 (33mil)	2-1/2"
V445*	2	ProSTUD 20 (18mil)	2-1/2"
U466	1 or 2	ProSTUD 20 (18mil)	2-1/2"
U493	1 or 2	ProSTUD 33 (33mil)	2-1/2"
V437	1 or 2	ProSTUD 20 (18mil)	2-1/2"

## ProSTUD Table 1: Minimum Depth of Pro STUD Required<sup>A</sup>

Hourly Rating	Min. stud depth (in)	No. of layers and thickness of gypsum board	UL U419	UL V438	UL V477	UL V489	UL V498
1	2-1/2"	1 layer, 1/2"	—	—	—	✓	—
1	3-5/8"	1 layer, 5/8"	✓	✓	✓	✓	✓
2	1-5/8"	2 layer, 1/2"	✓	✓	✓	✓	✓
2	1-5/8"	2 layer, 5/8"	✓	—	✓	✓	✓
2	2-1/2"	2 layer, 5/8"	—	✓	—	—	—
3	1-5/8"	3 layer, 1/2"	✓	✓	✓	✓	✓
3	1-5/8"	3 layer, 5/8"	✓	✓	✓	✓	✓
4	1-5/8"	4 layer, 1/2"	✓	✓	✓	✓	✓
4	1-5/8"	4 layer, 5/8"	✓	✓	✓	✓	✓

Notes:

<sup>A</sup>See UL listing for detailed requirements of construction of tested assembly.

\*ProSTUD meets or exceeds the description of the generic stud/track listed in the UL assembly



Complies with AISI S100-16 • AISI S220 • IBC 2018

## Structural Studs & Track

Industry standard nomenclature is used to identify MBA's products. The Steel Framing Industry Association has established standard designation codes for structural studs and track. In each case, the identification starts with the measurement of the width of the member, followed by a letter (S = stud and T = track) followed by the flange dimension. A hyphen is used to separate all of this from the thickness of the metal.

### Member Depth:

(Example: 6" = 600 x 1/100 inches)

All member depths are taken in 1/100 inches. For all "T" sections member depth is the inside to inside dimension.

### Flange Width:

(Example: 1 5/8" = 1.625" 162 x 1/100 inches)

All flange widths are taken in 1/100 inches.

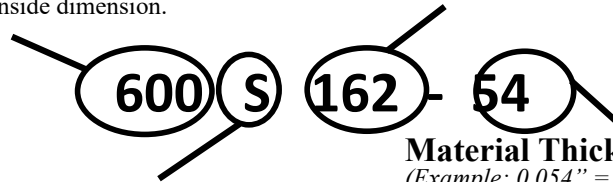

### Style:

(Example: Stud or Joist Section = S)

Relevant alpha characters utilized by the designation system are:

S = Stud or Joist Sections      T = Track Sections

### Material Thickness:

(Example: 0.054" = 54 mils; 1 mil = 1/1000 in.)

Material thickness is the minimum base metal thickness in mils.

Minimum base metal thickness represents 95% of the design thickness.

### Steel Thickness

Mils	Gauge	Thickness (in)	
		Design	Minimum <sup>1</sup>
33	20	0.0346	0.0329
43	18	0.0451	0.0428
54	16	0.0566	0.0538
68	14	0.0713	0.0677
97	12	0.1017	0.0966
118	10	0.1242	0.1180

<sup>1</sup> Minimum Thickness represents 95% of the design thickness and is the minimum acceptable thickness delivered to the job site based on AISI S100-16/S2-20.

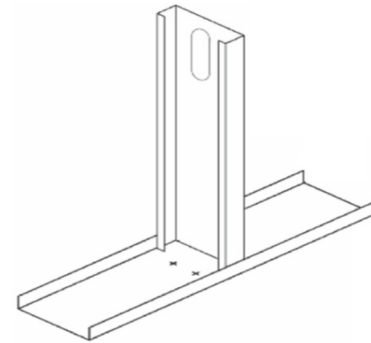

### Design Stiffening Lip Length

Section	Flange Width	Design Stiffening Lip Length (in)
S137	1-3/8"	0.375
S162	1-5/8"	0.500
S200	2"	0.625
S250	2-1/2"	0.625
S300	3"	1.000
S350	3-1/2"	1.000

### Structural Stud Punchouts

Punchouts for structural studs are ovals. These punchouts begin 12" from the lead end and are spaced at 24" o.c. intervals. The last punchout is 12" minimum from the trailing end of the stud. Care should be taken during installation to be sure the studs are oriented in the same direction to facilitate plumbing and electrical installation.

## General Notes

- Physical properties and load tables have been calculated in conformance with the AISI S100-16/S2-20.
- All structural framing members have a protective coating conforming to ASTM C 955.
- Reference ASTM specification A 1003/A 1003 M table 1 for the universe of allowable coatings for light gauge steel framing.
- Stud/joists are manufactured to custom lengths. Stud/joists are manufactured with punched webs unless otherwise specified at time of order.
- Track is produced in standard lengths of 10 feet unless a custom track length is indicated. Track is manufactured with unpunched webs.
- Structural framing members are marked with product information per the requirements of ASTM C 955 section 12.
- All delivered material must be kept dry, preferably by being stored inside a building under a roof. If it is necessary to store material outside, it must be stacked off the ground, properly supported on a level platform, and fully protected from the weather. Reference ASTM C 754 section 8 and ASTM C 1007 section 4.

## LEED Green Building Credits

MR Credit 2: Construction Waste Management – MBA steel framing is 100% recyclable.

MR Credit 4: Recycled Content – MBA steel framing is formed from no less than 25.5% post-consumer and 6.8% pre-consumer recycled content.

MR Credit 5: Regional Materials – MBA has manufacturing facilities in multiple states.

## Section Properties

### Section Properties Table Notes

1. Web depth for track sections is equal to the nominal height plus 2 times design thickness plus the bend radius.
2. Effective properties incorporate the strength increase from the cold work of forming as applicable per the AISI S100-16/S2-20.
3. Tabulated gross properties are based on the full, unreduced section away from punchouts.
4. Effective properties of all 'S' sections based on punched sections. Track sections are considered unpunched.
5. For deflection calculations, use the effective moment of inertia.
6. Where effective properties are not listed for a section at 33 or 50 ksi yield, web depth-to-thickness or flange width-to-thickness limits from the AISI are exceeded. Only gross properties are available.

## Structural (S) Stud Section Properties

Section	Design Thickness (in)	Gross Properties						Effective Properties (33ksi)						Effective 50ksi						Torsional									
		Area (in <sup>2</sup> )	Weight (lb/ft)	Ix (in <sup>4</sup> )	Sx (in <sup>3</sup> )	Rx (in)	Iy (in <sup>4</sup> )	Sy (in <sup>3</sup> )	Ry (in)	Ix (in <sup>4</sup> )	Sx (in <sup>3</sup> )	Ma	(in-k)	Vag	(lb)	Ixx (in <sup>4</sup> )	Sxx (in <sup>3</sup> )	Ma	(in-k)	Vag	(lb)	Vanet (lb)	J <sup>1000</sup> (in <sup>4</sup> )	Cw (in <sup>6</sup> )	Xo (in)	Yo (in)	Ro (in)	β	
250S137-33	0.0346	0.197	0.67	0.203	0.163	1.015	0.052	0.515	0.203	0.158	3.11		975	399										0.079	0.076	-1.141	0.677	1.612	0.499
250S137-43	0.0451	0.255	0.87	0.261	0.208	1.01	0.067	0.511	0.261	0.205	4.53 <sup>2</sup>		1265	394										0.173	0.096	-1.129	0.67	1.599	0.501
250S137-54	0.0566	0.316	1.07	0.318	0.255	1.004	0.08	0.504	0.318	0.255	5.76 <sup>2</sup>		1553	373	0.318	0.244	8.22 <sup>2</sup>	2353	565	0.337	0.115	-1.115	0.663	1.583	0.504				
250S137-68	0.0713	0.39	1.33	0.386	0.309	0.994	0.095	0.495	0.386	0.309	7.19 <sup>2</sup>		1891	342	0.386	0.308	10.65 <sup>2</sup>	2866	519	0.661	0.138	-1.096	0.653	1.561	0.507				
250S162-33	0.0346	0.223	0.76	0.235	0.188	1.027	0.087	0.624	0.235	0.18	3.55		975	399										0.089	0.146	-1.47	0.859	1.898	0.401
250S162-43	0.0451	0.289	0.98	0.302	0.242	1.022	0.111	0.62	0.302	0.24	5.22 <sup>2</sup>		1265	394										0.196	0.184	-1.457	0.852	1.885	0.402
250S162-54	0.0566	0.358	1.22	0.37	0.296	1.016	0.135	0.613	0.37	0.296	6.57 <sup>2</sup>		1553	373	0.37	0.284	9.42 <sup>2</sup>	2353	565	0.383	0.223	-1.443	0.845	1.868	0.403				
250S162-68	0.0713	0.443	1.51	0.45	0.36	1.007	0.162	0.605	0.45	0.36	8.21 <sup>2</sup>		1891	342	0.45	0.357	12.11 <sup>2</sup>	2866	519	0.752	0.268	-1.424	0.835	1.846	0.405				
350S162-33	0.0346	0.258	0.88	0.508	0.29	1.404	0.098	0.617	0.508	0.257	5.08		1024	487										0.103	0.277	-1.324	0.796	2.036	0.573
350S162-43	0.0451	0.334	1.14	0.654	0.374	1.4	0.125	0.612	0.654	0.357	7.05		1739	631										0.227	0.35	-1.312	0.789	2.014	0.575
350S162-54	0.0566	0.415	1.41	0.804	0.46	1.392	0.152	0.606	0.804	0.447	8.83		2353	633	0.804	0.426	12.74	3372	947	0.443	0.426	-1.298	0.782	1.998	0.578				
350S162-68	0.0713	0.515	1.75	0.985	0.563	1.383	0.184	0.597	0.985	0.551	10.89		2774	592	0.985	0.549	16.44	4202	897	0.872	0.514	-1.28	0.772	1.977	0.581				
362S137-33	0.0346	0.236	0.8	0.479	0.264	1.424	0.059	0.501	0.479	0.232	4.59		1024	521										0.094	0.165	-1.003	0.615	1.813	0.694
362S137-43	0.0451	0.306	1.04	0.616	0.34	1.419	0.075	0.497	0.616	0.32	6.32		1739	676										0.207	0.208	-0.991	0.608	1.801	0.697
362S137-54	0.0566	0.379	1.29	0.756	0.417	1.411	0.091	0.48	0.756	0.402	7.94		2341	705	0.756	0.381	11.42	3372	1016	0.405	0.251	-0.978	0.601	1.785	0.7				
362S137-68	0.0713	0.47	1.6	0.922	0.509	1.401	0.109	0.49	0.922	0.498	9.84		2884	662	0.922	0.493	14.77	4370	1004	0.797	0.302	-0.959	0.592	1.764	0.704				
362S162-33	0.0346	0.262	0.89	0.551	0.304	1.45	0.099	0.616	0.551	0.268	5.29		1024	521										0.105	0.297	-1.308	0.789	2.048	0.592
362S162-43	0.0451	0.34	1.16	0.71	0.392	1.445	0.127	0.611	0.71	0.372	7.34		1739	676										0.23	0.376	-1.297	0.782	2.036	0.594
362S162-54	0.0566	0.422	1.44	0.873	0.481	1.438	0.154	0.604	0.873	0.466	9.22		2341	705	0.873	0.444	13.28	3372	1016	0.451	0.457	-1.283	0.774	2.02	0.597				
362S162-68	0.0713	0.524	1.78	1.069	0.59	1.429	0.186	0.596	1.069	0.579	11.43		2884	662	1.069	0.574	17.18	4370	1004	0.884	0.552	-1.264	0.765	1.998	0.6				
362S200-33	0.0346	0.297	1.01	0.648	0.358	1.478	0.177	0.772	0.647	0.294	5.81		1024	521										0.118	0.577	-1.741	1.03	2.411	0.478
362S200-43	0.0451	0.385	1.31	0.836	0.461	1.474	0.227	0.767	0.836	0.427	8.43		1739	676										0.261	0.734	-1.729	1.024	2.398	0.48
362S200-54	0.0566	0.479	1.63	1.03	0.568	1.467	0.277	0.761	1.03	0.553	10.93		2341	705	1.03	0.49	14.66	3372	1016	0.511	0.896	-1.715	1.016	2.382	0.482				
362S200-68	0.0713	0.595	2.02	1.265	0.698	1.458	0.337	0.753	1.265	0.687	13.58		2884	662	1.265	0.666	19.95	4370	1004	1.008	1.089	-1.696	1.006	2.36	0.484				
400S137-33	0.0346	0.249	0.85	0.603	0.301	1.556	0.061	0.496	0.603	0.259	5.12		976	595										0.099	0.204	-0.965	0.597	1.897	0.741
400S137-43	0.0451	0.323	1.1	0.776	0.388	1.551	0.078	0.491	0.776	0.359	7.09		1739	810										0.219	0.257	-0.954	0.591	1.885	0.744
400S137-54	0.0566	0.401	1.36	0.953	0.477	1.542	0.094	0.484	0.953	0.453	8.96		2603	944	0.953	0.428	12.82	3372	1223	0.428	0.311	-0.94	0.583	1.87	0.747				
400S137-68	0.0713	0.497	1.69	1.165	0.582	1.531	0.112	0.475	1.165	0.567	11.21		3215	895	1.165	0.558	16.7	4871	1956	0.842	0.375	-0.922	0.574	1.849	0.751				
400S162-33	0.0346	0.275	0.94	0.692	0.346	1.586	0.103	0.611	0.692	0.299	5.91		976	595										0.11	0.363	-1.263	0.768	2.118	0.644
400S162-43	0.0451	0.357	1.21	0.892	0.446	1.581	0.131	0.606	0.892	0.417	8.23		1739	810										0.242	0.46	-1.252	0.761	2.106	0.647
400S162-54	0.0566	0.443	1.51	1.098	0.549	1.574	0.159	0.6	1.098	0.526	10.39		2603	944	1.098	0.498	14.9	3372	1223	0.473	0.56	-1.238	0.754	2.09	0.649				
400S162-68	0.0713	0.55	1.87	1.346	0.673	1.564	0.192	0.591	1.346	0.658	13		3215	895	1.346	0.648	19.41	4871	1956	0.933	0.677	-1.22	0.745	2.069	0.653				
400S200-33	0.0346	0.31	1.05	0.812	0.406	1.619	0.183	0.769	0.812	0.328	6.49		976	595										0.124	0.697	-1.688	1.007	2.462	0.53
400S200-43	0.0451	0.402	1.37	1.047	0.524	1.615	0.235	0.764	1.047	0.478	9.45		1739	810										0.272	0.886	-1.676	1	2.449	0.532
400S200-54	0.0566	0.5	1.7	1.292	0.646	1.608	0.287	0.758	1.292	0.623	12.3		2603	944	1.292	0.549	16.43	3372	1223	0.534	1.083	-1.662	0.993	2.433	0.534				
400S200-68	0.0713	0.622	2.12	1.589	0.795	1.599	0.349	0.75	1.589	0.78	15.4		3215	895	1.589	0.751	22.48	4871	1956	1.054	1.318	-1.643	0.983	2.412	0.536				
550S162-33	0.0346	0.327	1.11	1.458	0.53	2.112	0.113	0.589	1.458	0.512	10.11		699	699										0.13	0.713	-1.114	0.697	2.459	0.795
550S162-43	0.0451	0.424	1.44	1.883	0.685	2.107	0.145	0.584	1.883	0.681	14.79 <sup>2</sup>		1199	1199										0.288	0.905	-1.103	0.691	2.448	0.797
550S162-54	0.0566	0.528	1.8	2.324	0.845	2.098	0.176	0.577	2.324	0.845	18.76 <sup>2</sup>		1739	1666	2.324	0.811	26.86 <sup>2</sup>	3093	1881	0.564	1.105	-1.09	0.684	2.434	0.8				
550S162-68	0.0713	0.657	2.24	2.861	1.04	2.086	0.212	0.568	2.861	1.04	23.72 <sup>2</sup>		4347	2057	2.861	1.031	34.94 <sup>2</sup>	5350	2532	1.114	1.342	-1.072	0.675	2.414	0.803				
600S137-33	0.0346	0.318	1.08	1.582	0.527	2.229	0.069	0.464	1.548	0.455	8.98		638	638										0.127	0.5	-0.807	0.519	2.416	0.889
600S137-43	0.0451	0.413	1.41	2.042	0.681	2.223	0.087	0.459	2.041	0.645	12.74		1416	1240										0.28	0.633	-0.796	0.513	2.406	0.89
600S137-54	0.0566	0.514	1.75	2.518	0.839	2.213	0.105	0.452	2.518	0.832	16.44		2739	1890	2.518	0.777	23.26	2823	1947	0.529	0.769	-0.784	0.506	2.391	0.893				
600S137-68	0.0713	0.64	2.18	3.094	1.031	2.2	0.125	0.443	3.094	1.031	24.05 <sup>2</sup>		4347	2339	3.094	1.03	30.84	5350	2879	1.084	0.93	-0.768	0.497	2.371	0.895				
600S137-97	0.1017	0.889																											

## Section Properties (Continued)

### Structural (S) Stud Section Properties

Section	Design Thickness (in)	Gross Properties							Effective Properties (33ksi)					Effective 50ksi					Torsional					
		Area (in <sup>2</sup> )	Weight (lb/ft)	I <sub>x</sub> (in <sup>4</sup> )	S <sub>x</sub> (in <sup>3</sup> )	R <sub>x</sub> (in)	I <sub>y</sub> (in <sup>4</sup> )	R <sub>y</sub> (in)	I <sub>x</sub> (in <sup>4</sup> )	S <sub>x</sub> (in <sup>3</sup> )	Ma (in-k)	V <sub>ag</sub> (lb)	V <sub>anet</sub> (lb)	I <sub>xx</sub> (in <sup>4</sup> )	S <sub>xx</sub> (in <sup>3</sup> )	Ma (in-k)	V <sub>ag</sub> (lb)	V <sub>anet</sub> (lb)	J <sup>x1000</sup> (in <sup>4</sup> )	C <sub>w</sub> (in <sup>6</sup> )	X <sub>o</sub> (in)	m (in)	R <sub>o</sub> (in)	β
600S200-33	0.0346	0.379	1.29	2.075	0.692	2.340	0.209	0.743	2.058	0.621	12.28 <sup>2</sup>	638	638						0.151	1.593	-1.457	0.901	2.855	0.740
600S200-43	0.0451	0.492	1.67	2.683	0.894	2.335	0.268	0.739	2.683	0.873	17.24	1416	1240						0.334	2.033	-1.446	0.894	2.844	0.742
600S200-54	0.0566	0.613	2.09	3.319	1.106	2.327	0.328	0.732	3.319	1.106	24.07 <sup>2</sup>	2739	1890	3.319	1.015	30.40	2823	1947	0.655	2.493	-1.432	0.887	2.829	0.744
600S200-68	0.0713	0.764	2.60	4.101	1.367	2.316	0.400	0.723	4.101	1.367	30.42 <sup>2</sup>	4347	2339	4.101	1.317	43.71 <sup>2</sup>	5350	2879	1.295	3.047	-1.415	0.878	2.809	0.746
600S200-97	0.1017	1.067	3.63	5.612	1.871	2.293	0.530	0.705	5.612	1.871	43.49 <sup>2</sup>	6911	2512	5.612	1.871	64.53 <sup>2</sup>	10472	3805	3.679	4.080	-1.378	0.859	2.767	0.752
600S250-43	0.0451	0.537	1.83	3.082	1.027	2.396	0.458	0.923	3.082	0.918	18.14	1416	1240						0.364	3.411	-1.874	1.136	3.179	0.652
600S250-54	0.0566	0.670	2.28	3.819	1.273	2.388	0.562	0.917	3.819	1.159	22.90	2739	1890	3.766	1.069	32.00	2823	1947	0.715	4.194	-1.860	1.129	3.163	0.654
600S250-68	0.0713	0.836	2.84	4.727	1.576	2.378	0.688	0.908	4.727	1.508	32.82 <sup>2</sup>	4347	2339	4.723	1.386	41.49	5350	2879	1.416	5.145	-1.842	1.119	3.142	0.656
600S250-97	0.1017	1.169	3.98	6.496	2.165	2.357	0.923	0.889	6.496	2.161	48.81 <sup>2</sup>	6911	2512	6.496	2.063	69.38 <sup>2</sup>	10472	3805	4.030	6.947	-1.803	1.100	3.098	0.661
800S137-33 <sup>1</sup>	0.0346	0.388	1.32	3.198	0.799	2.873	0.073	0.435	2.998	0.622	12.30	474	474						0.155	0.957	-0.696	0.460	2.987	0.946
800S137-43	0.0451	0.503	1.71	4.134	1.033	2.866	0.093	0.430	4.001	0.896	17.70	1051	1051						0.341	1.214	-0.687	0.454	2.978	0.947
800S137-54	0.0566	0.627	2.13	5.110	1.277	2.855	0.112	0.423	5.077	1.179	23.29	2091	2091	4.974	1.083	32.42	2091	2091	0.670	1.478	-0.676	0.448	2.964	0.948
800S137-68	0.0713	0.782	2.66	6.303	1.576	2.839	0.134	0.414	6.303	1.541	30.45	4221	3367	6.285	1.468	43.96	4221	3367	1.325	1.789	-0.661	0.440	2.944	0.950
800S137-97	0.1017	1.093	3.72	8.597	2.149	2.805	0.169	0.394	8.597	2.149	53.09 <sup>2</sup>	8843	4824	8.597	2.149	64.35	10885	5938	3.767	2.349	-0.630	0.423	2.902	0.953
800S162-33 <sup>1</sup>	0.0346	0.413	1.41	3.582	0.896	2.943	0.125	0.550	3.384	0.710	14.03	474	474						0.165	1.630	-0.936	0.607	3.137	0.911
800S162-43	0.0451	0.537	1.83	4.633	1.158	2.937	0.160	0.546	4.500	1.019	20.14	1051	1051						0.364	2.076	-0.926	0.601	3.128	0.912
800S162-54	0.0566	0.670	2.28	5.736	1.434	2.927	0.194	0.539	5.702	1.334	26.36	2091	2091	5.600	1.229	36.79	2091	2091	0.715	2.539	-0.914	0.594	3.113	0.914
800S162-68	0.0713	0.836	2.84	7.089	1.772	2.913	0.235	0.530	7.089	1.737	34.32	4221	3367	7.070	1.663	49.80	4221	3367	1.416	3.093	-0.899	0.586	3.094	0.916
800S162-97	0.1017	1.169	3.98	9.713	2.428	2.883	0.305	0.510	9.713	2.428	58.27 <sup>2</sup>	8843	4824	9.713	2.428	72.70	10885	5938	4.030	4.114	-0.866	0.568	3.053	0.919
800S200-33 <sup>1</sup>	0.0346	0.448	1.52	4.096	1.024	3.023	0.227	0.712	4.096	0.816	16.12	474	474						0.179	2.971	-1.288	0.817	3.363	0.853
800S200-43	0.0451	0.582	1.98	5.302	1.325	3.018	0.292	0.708	5.302	1.293	25.54	1051	1051						0.395	3.797	-1.277	0.811	3.353	0.855
800S200-54	0.0566	0.726	2.47	6.573	1.643	3.009	0.357	0.701	6.573	1.643	35.75 <sup>2</sup>	2091	2091	6.573	1.499	44.87	2091	2091	0.775	4.663	-1.265	0.804	3.338	0.856
800S200-68	0.0713	0.907	3.09	8.140	2.035	2.996	0.435	0.692	8.140	2.035	45.29 <sup>2</sup>	4221	3367	8.140	1.964	65.21 <sup>2</sup>	4221	3367	1.537	5.712	-1.248	0.796	3.319	0.859
800S200-97	0.1017	1.271	4.32	11.203	2.801	2.969	0.576	0.673	11.203	2.801	65.12 <sup>2</sup>	8843	4824	11.203	2.801	96.63 <sup>2</sup>	10885	5938	4.381	7.684	-1.214	0.777	3.278	0.863
800S250-43	0.0451	0.627	2.13	6.015	1.504	3.097	0.500	0.893	6.015	1.313	25.95	1051	1051						0.425	6.374	-1.675	1.043	3.632	0.787
800S250-54	0.0566	0.783	2.66	7.465	1.866	3.088	0.614	0.886	7.465	1.712	33.82	2091	2091	7.378	1.525	45.66	2091	2091	0.836	7.850	-1.661	1.036	3.617	0.789
800S250-68	0.0713	0.978	3.33	9.261	2.315	3.077	0.752	0.877	9.261	2.220	48.33 <sup>2</sup>	4221	3367	9.240	2.059	61.65	4221	3367	1.658	9.652	-1.644	1.027	3.597	0.791
800S250-97	0.1017	1.372	4.67	12.789	3.197	3.053	1.009	0.857	12.789	3.191	72.07 <sup>2</sup>	8843	4824	12.789	3.054	102.70 <sup>2</sup>	10885	5938	4.731	13.091	-1.607	1.008	3.555	0.796
1000S162-43 <sup>1</sup>	0.0451	0.627	2.13	8.025	1.605	3.577	0.168	0.518	7.523	1.302	25.74	836	836						0.425	3.430	-0.823	0.545	3.707	0.951
1000S162-54	0.0566	0.783	2.66	9.950	1.990	3.565	0.204	0.511	9.627	1.722	34.02	1661	1661	9.391	1.572	47.07	1661	1661	0.836	4.198	-0.812	0.538	3.692	0.952
1000S162-68	0.0713	0.978	3.33	12.325	2.465	3.550	0.246	0.502	12.256	2.276	44.98	3345	3345	11.978	2.154	64.51	3345	3345	1.658	5.121	-0.798	0.531	3.673	0.953
1000S162-97	0.1017	1.372	4.67	16.967	3.393	3.516	0.320	0.483	16.967	3.393	67.06	8843	6434	16.967	3.269	97.89	9864	7177	4.731	6.827	-0.768	0.514	3.631	0.955
1000S200-43 <sup>1</sup>	0.0451	0.672	2.29	9.085	1.817	3.676	0.309	0.677	8.602	1.470	29.05	836	836						0.456	6.236	-1.147	0.743	3.910	0.914
1000S200-54	0.0566	0.839	2.86	11.278	2.256	3.666	0.378	0.671	10.953	1.984	39.20	1661	1661	10.769	1.705	51.05	1661	1661	0.896	7.665	-1.135	0.737	3.896	0.915
1000S200-68	0.0713	1.050	3.57	13.994	2.799	3.652	0.460	0.662	13.920	2.607	51.51	3345	3345	13.665	2.420	72.46	3345	3345	1.779	9.401	-1.120	0.729	3.876	0.917
1000S200-97	0.1017	1.474	5.02	19.336	3.867	3.622	0.609	0.643	19.336	3.867	76.42	8843	6434	19.336	3.741	112.00	9864	7177	5.082	12.679	-1.088	0.711	3.836	0.920
1000S250-43 <sup>1</sup>	0.0451	0.717	2.44	10.203	2.041	3.771	0.531	0.860	10.203	1.617	31.95	836	836						0.486	10.481	-1.518	0.965	4.155	0.867
1000S250-54	0.0566	0.896	3.05	12.677	2.535	3.762	0.653	0.854	12.677	2.277	44.99	1661	1661	12.660	1.879	56.26	1661	1661	0.957	12.922	-1.505	0.958	4.140	0.868
1000S250-68	0.0713	1.121	3.81	15.751	3.150	3.749	0.799	0.844	15.751	3.028	65.93 <sup>2</sup>	3345	3345	15.741	2.768	82.89	3345	3345	1.899	15.909	-1.488	0.950	4.121	0.870
1000S250-97	0.1017	1.576	5.36	21.827	4.365	3.722	1.072	0.825	21.827	4.357	98.41 <sup>2</sup>	8843	6434	21.827	4.181	140.63 <sup>2</sup>	9864	7177	5.433	21.632	-1.454	0.932	4.080	0.873
1200S162-54 <sup>1</sup>	0.0566	0.896	3.05	15.730	2.622	4.190	0.212	0.486	14.743	2.109	41.68	1377	1377	14.298	1.914	57.31	1377	1377	0.957	6.340	-0.732	0.493	4.281	0.971
1200S162-68	0.0713	1.121	3.81	19.518	3.253	4.173	0.255	0.477	18.955	2.817	55.66	2771	2771	18.390	2.645	79.19	2771	2771	1.899	7.739	-0.719	0.485	4.261	0.972
1200S162-97	0.1017	1.576	5.36	26.966	4.494	4.137	0.331	0.459	26.966	4.327	85.51	8147	7411	26.735	4.091	122.49	8147	7411	5.433	10.331	-0.691	0.470	4.219	0.973
1200S200-54 <sup>1</sup>	0.0566	0.953	3.24	17.662	2.944	4.306	0.393	0.643	16.678	2.425	47.93	1377	1377	16.334	2.073	62.07	1377	1377	1.017	11.550	-1.032	0.681	4.474	0.947
1200S200-68	0.0713	1.192	4.06	21.947	3.658	4.291	0.479	0.634	21.376	3.215	63.54	2771	2771	20.864	2.963	88.71	2771	2771	2.020	14.176	-1.017	0.673	4.455	0.948
1200S200-97	0.1017	1.677	5.71	30.417	5.069	4.258	0.635	0.615	30.417	4.899	96.81	8147	7411	30.175	4.660	139.51	8147	7411	5.783	19.150	-0.987	0.656	4.414	0.950
1200S250-54 <sup>1</sup>	0																							

## Section Properties

### Section Properties Table Notes

1. Web depth for track sections is equal to the nominal height plus 2 times design thickness plus the bend radius.
2. Effective properties incorporate the strength increase from the cold work of forming as applicable per the AISI S100-16/S2-20
3. Tabulated gross properties are based on the full, unreduced section away from punchouts.
4. Effective properties of all 'S' sections based on punched sections. Track sections are considered unpunched.
5. For deflection calculations, use the effective moment of inertia.
6. Where effective properties are not listed for a section at 33 or 50 ksi yield, web depth-to-thickness or flange width-to-thickness limits from the AISI are exceeded. Only gross properties are available.

### Structural (T) Track Section Properties

Section	Design Thickness (in)	Gross Properties							Effective Properties (33ksi)				Effective 50ksi				Torsional					
		Area (in <sup>2</sup> )	Weight (lb/ft)	I <sub>x</sub> (in <sup>4</sup> )	S <sub>x</sub> (in <sup>3</sup> )	R <sub>x</sub> (in)	I <sub>y</sub> (in <sup>4</sup> )	R <sub>y</sub> (in)	I <sub>x</sub> (in <sup>4</sup> )	S <sub>x</sub> (in <sup>3</sup> )	Ma (in-k)	V <sub>ag</sub> (lb)	I <sub>xx</sub> (in <sup>4</sup> )	S <sub>xx</sub> (in <sup>3</sup> )	Ma (in-k)	V <sub>a</sub> (lb)	J <sup>x1000</sup> (in <sup>4</sup> )	C <sub>w</sub> (in <sup>6</sup> )	X <sub>o</sub> (in)	m (in)	R <sub>o</sub> (in)	β
162T125-18	0.0188	0.077	0.26	0.041	0.047	0.733	0.013	0.411	0.030	0.025	0.50	302				0.009	0.007	-0.878	0.503	1.215	0.478	
162T125-27	0.0283	0.117	0.40	0.063	0.072	0.735	0.020	0.410	0.050	0.044	0.87	541				0.031	0.010	-0.872	0.501	1.211	0.482	
162T125-30	0.0312	0.129	0.44	0.070	0.079	0.735	0.022	0.409	0.057	0.050	1.00	597				0.042	0.012	-0.870	0.500	1.210	0.483	
162T125-33	0.0346	0.143	0.49	0.077	0.087	0.736	0.024	0.408	0.066	0.058	1.15	663				0.057	0.013	-0.868	0.499	1.209	0.484	
250T125-18	0.0188	0.094	0.32	0.103	0.079	1.051	0.015	0.400	0.078	0.045	0.90	249				0.011	0.018	-0.769	0.460	1.362	0.681	
250T125-27	0.0283	0.141	0.48	0.157	0.119	1.053	0.022	0.398	0.129	0.079	1.56	685				0.038	0.027	-0.763	0.457	1.360	0.685	
250T125-30	0.0312	0.156	0.53	0.173	0.131	1.053	0.025	0.397	0.145	0.090	1.77	832				0.051	0.030	-0.762	0.456	1.359	0.686	
250T125-33	0.0346	0.173	0.59	0.192	0.145	1.054	0.027	0.397	0.166	0.103	2.03	1024				0.069	0.033	-0.760	0.456	1.358	0.687	
250T125-43	0.0451	0.225	0.77	0.250	0.188	1.055	0.035	0.395	0.231	0.147	2.91	1356				0.153	0.042	-0.755	0.453	1.356	0.690	
250T125-54	0.0566	0.282	0.96	0.318	0.236	1.062	0.043	0.392	0.310	0.203	4.01	1692	0.297	0.188	5.64	2563	0.301	0.054	-0.749	0.449	1.357	0.696
250T125-68	0.0713	0.355	1.21	0.408	0.297	1.072	0.054	0.389	0.408	0.281	5.56	2111	0.402	0.262	7.85	3199	0.602	0.069	-0.740	0.444	1.360	0.704
250T150-27	0.0283	0.156	0.53	0.181	0.137	1.078	0.037	0.486	0.139	0.082	1.61	685				0.042	0.044	-0.976	0.575	1.534	0.595	
250T150-30	0.0312	0.172	0.58	0.199	0.151	1.078	0.040	0.486	0.157	0.093	1.83	832				0.056	0.049	-0.975	0.574	1.533	0.595	
250T150-33	0.0346	0.190	0.65	0.221	0.167	1.079	0.045	0.485	0.179	0.107	2.11	1024				0.076	0.054	-0.973	0.573	1.532	0.596	
250T150-43	0.0451	0.248	0.84	0.289	0.217	1.080	0.058	0.483	0.252	0.154	3.03	1356				0.168	0.070	-0.968	0.570	1.529	0.599	
250T150-54	0.0566	0.311	1.06	0.368	0.273	1.088	0.072	0.481	0.342	0.213	4.22	1692	0.325	0.197	5.89	2563	0.332	0.089	-0.961	0.566	1.529	0.605
250T150-68	0.0713	0.391	1.33	0.472	0.344	1.099	0.089	0.478	0.465	0.299	5.92	2111	0.445	0.276	8.27	3199	0.663	0.114	-0.953	0.561	1.531	0.613
250T200-33	0.0346	0.225	0.76	0.280	0.212	1.117	0.097	0.658	0.203	0.112	2.22	1024				0.090	0.118	-1.418	0.813	1.921	0.455	
250T200-43	0.0451	0.293	1.00	0.366	0.275	1.118	0.126	0.657	0.288	0.163	3.21	1356				0.198	0.153	-1.413	0.810	1.918	0.457	
250T200-54	0.0566	0.367	1.25	0.466	0.346	1.127	0.157	0.654	0.396	0.228	4.51	1692	0.371	0.209	6.25	2563	0.392	0.195	-1.405	0.806	1.917	0.462
250T200-68	0.0713	0.462	1.57	0.600	0.437	1.139	0.196	0.652	0.548	0.324	6.41	2111	0.517	0.296	8.86	3199	0.783	0.251	-1.396	0.800	1.916	0.469
350T125-18	0.0188	0.113	0.38	0.219	0.121	1.394	0.016	0.383	0.174	0.063	1.25	175				0.013	0.038	-0.675	0.418	1.595	0.821	
350T125-27	0.0283	0.170	0.58	0.331	0.182	1.396	0.025	0.381	0.277	0.128	2.53	590				0.045	0.057	-0.670	0.416	1.595	0.823	
350T125-30	0.0312	0.187	0.64	0.365	0.200	1.396	0.027	0.380	0.312	0.145	2.86	790				0.061	0.063	-0.669	0.415	1.594	0.824	
350T125-33	0.0346	0.207	0.71	0.405	0.222	1.397	0.030	0.379	0.354	0.165	3.27	1024				0.083	0.070	-0.668	0.414	1.594	0.824	
350T125-43	0.0451	0.270	0.92	0.528	0.288	1.397	0.038	0.377	0.490	0.233	4.61	1739				0.183	0.090	-0.663	0.412	1.592	0.826	
350T125-54	0.0566	0.339	1.15	0.668	0.361	1.404	0.048	0.375	0.651	0.317	6.26	2392	0.626	0.297	8.89	3372	0.362	0.114	-0.658	0.408	1.595	0.830
350T125-68	0.0713	0.427	1.45	0.851	0.454	1.412	0.059	0.372	0.851	0.433	8.55	2994	0.839	0.407	12.18	4536	0.723	0.144	-0.650	0.403	1.599	0.835
350T150-27	0.0283	0.184	0.63	0.377	0.207	1.431	0.041	0.470	0.298	0.132	2.62	590				0.049	0.094	-0.869	0.529	1.739	0.750	
350T150-30	0.0312	0.203	0.69	0.416	0.228	1.432	0.045	0.469	0.336	0.150	2.96	790				0.066	0.103	-0.867	0.528	1.739	0.751	
350T150-33	0.0346	0.225	0.76	0.461	0.253	1.432	0.049	0.469	0.382	0.171	3.39	1024				0.090	0.114	-0.866	0.527	1.738	0.752	
350T150-43	0.0451	0.293	1.00	0.601	0.328	1.433	0.064	0.467	0.531	0.243	4.80	1739				0.198	0.148	-0.861	0.525	1.736	0.754	
350T150-54	0.0566	0.367	1.25	0.761	0.412	1.440	0.079	0.465	0.712	0.332	6.57	2392	0.679	0.31	9.28	3372	0.392	0.187	-0.855	0.521	1.738	0.758
350T150-68	0.0713	0.462	1.57	0.972	0.518	1.450	0.099	0.462	0.957	0.459	9.07	2994	0.919	0.428	12.81	4536	0.783	0.238	-0.847	0.516	1.741	0.763
350T200-33	0.0346	0.259	0.88	0.574	0.315	1.487	0.108	0.647	0.428	0.181	3.57	1024				0.103	0.249	-1.285	0.761	2.069	0.614	
350T200-43	0.0451	0.338	1.15	0.749	0.409	1.489	0.140	0.645	0.600	0.257	5.09	1739				0.229	0.323	-1.280	0.758	2.066	0.616	
350T200-54	0.0566	0.424	1.44	0.949	0.513	1.496	0.175	0.642	0.814	0.355	7.01	2392	0.77	0.329	9.85	3372	0.453	0.409	-1.273	0.754	2.067	0.621
350T200-68	0.0713	0.534	1.82	1.213	0.647	1.508	0.218	0.639	1.112	0.496	9.80	2994	1.054	0.458	13.71	4536	0.904	0.522	-1.264	0.749	2.069	0.626
362T125-18	0.0188	0.115	0.39	0.237	0.126	1.435	0.017	0.380	0.189	0.065	1.29	169				0.014	0.042	-0.665	0.413	1.627	0.833	
362T125-27	0.0283	0.173	0.59	0.358	0.191	1.438	0.025	0.378	0.301	0.135	2.66	569				0.046	0.062	-0.661	0.411	1.627	0.835	
362T125-30	0.0312	0.191	0.65	0.395	0.210	1.438	0.027	0.378	0.339	0.152	3.01	762				0.062	0.068	-0.659	0.410	1.626	0.836	

<sup>1</sup> Web-height to thickness ratio exceeds 200. Web Stiffeners are required at all support points and concentrated loads.

<sup>2</sup> Allowable moment includes cold-work of forming.

## Section Properties (Continued)

### Structural (T) Track Section Properties

Section	Design Thickness (in)	Gross Properties						Effective Properties (33ksi)						Effective 50ksi				Torsional				
		Area (in <sup>2</sup> )	Weight (lb/ft)	I <sub>x</sub> (in <sup>4</sup> )	S <sub>x</sub> (in <sup>3</sup> )	R <sub>x</sub> (in)	I <sub>y</sub> (in <sup>4</sup> )	R <sub>y</sub> (in)	I <sub>x</sub> (in <sup>4</sup> )	S <sub>x</sub> (in <sup>3</sup> )	Ma (in-k)	V <sub>ag</sub> (lb)	I <sub>xx</sub> (in <sup>4</sup> )	S <sub>xx</sub> (in <sup>3</sup> )	Ma (in-k)	V <sub>a</sub> (lb)	J <sup>x1000</sup> (in <sup>4</sup> )	C <sub>w</sub> (in <sup>6</sup> )	X <sub>o</sub> (in)	m (in)	R <sub>o</sub> (in)	β
362T125-33	0.0346	0.212	0.72	0.438	0.232	1.438	0.030	0.377	0.384	0.174	3.44	1024					0.085	0.076	-0.658	0.409	1.626	0.836
362T125-43	0.0451	0.276	0.94	0.571	0.302	1.439	0.039	0.375	0.531	0.245	4.84	1739					0.187	0.098	-0.654	0.407	1.625	0.838
362T125-54	0.0566	0.346	1.18	0.723	0.378	1.445	0.048	0.373	0.705	0.332	6.57	2480	0.678	0.312	9.34	3372	0.369	0.123	-0.648	0.404	1.627	0.841
362T125-68	0.0713	0.436	1.48	0.921	0.475	1.454	0.060	0.370	0.921	0.453	8.95	3104	0.907	0.427	12.78	4703	0.738	0.156	-0.641	0.399	1.631	0.846
362T150-27	0.0283	0.187	0.64	0.408	0.217	1.475	0.041	0.468	0.323	0.140	2.76	569					0.050	0.102	-0.857	0.524	1.769	0.765
362T150-30	0.0312	0.207	0.70	0.449	0.239	1.475	0.045	0.467	0.364	0.158	3.12	762					0.067	0.112	-0.856	0.523	1.768	0.766
362T150-33	0.0346	0.229	0.78	0.499	0.264	1.475	0.050	0.467	0.414	0.180	3.56	1024					0.091	0.124	-0.854	0.522	1.767	0.766
362T150-43	0.0451	0.298	1.02	0.650	0.343	1.476	0.064	0.465	0.574	0.255	5.04	1739					0.202	0.160	-0.850	0.519	1.766	0.768
362T150-54	0.0566	0.374	1.27	0.823	0.431	1.483	0.080	0.462	0.769	0.349	6.89	2480	0.735	0.325	9.74	3372	0.400	0.202	-0.844	0.516	1.768	0.772
362T150-68	0.0713	0.471	1.60	1.050	0.542	1.492	0.099	0.459	1.034	0.480	9.49	3104	0.993	0.449	13.43	4703	0.799	0.257	-0.836	0.511	1.771	0.777
362T200-33	0.0346	0.264	0.90	0.619	0.328	1.532	0.110	0.645	0.464	0.190	3.76	1024					0.105	0.269	-1.270	0.754	2.092	0.631
362T200-43	0.0451	0.343	1.17	0.808	0.427	1.534	0.142	0.643	0.649	0.270	5.34	1739					0.233	0.350	-1.265	0.752	2.090	0.633
362T200-54	0.0566	0.431	1.47	1.024	0.536	1.541	0.177	0.640	0.879	0.372	7.35	2480	0.832	0.345	10.34	3372	0.460	0.442	-1.259	0.748	2.091	0.637
362T200-68	0.0713	0.543	1.85	1.307	0.675	1.552	0.221	0.638	1.199	0.519	10.26	3104	1.138	0.48	14.37	4703	0.919	0.564	-1.250	0.743	2.093	0.643
400T125-18 <sup>1</sup>	0.0188	0.122	0.41	0.297	0.144	1.560	0.017	0.374	0.241	0.072	1.42	153					0.014	0.052	-0.637	0.400	1.726	0.864
400T125-27	0.0283	0.184	0.63	0.449	0.217	1.562	0.025	0.372	0.380	0.156	3.08	515					0.049	0.078	-0.633	0.398	1.726	0.866
400T125-30	0.0312	0.203	0.69	0.495	0.239	1.562	0.028	0.371	0.427	0.176	3.49	689					0.066	0.085	-0.632	0.397	1.726	0.866
400T125-33	0.0346	0.225	0.76	0.549	0.265	1.563	0.031	0.371	0.484	0.201	3.97	940					0.090	0.095	-0.630	0.396	1.725	0.867
400T125-43	0.0451	0.293	1.00	0.716	0.344	1.563	0.040	0.369	0.666	0.282	5.57	1739					0.198	0.122	-0.626	0.394	1.724	0.868
400T125-54	0.0566	0.367	1.25	0.904	0.431	1.569	0.049	0.366	0.882	0.381	7.53	2739	0.849	0.359	10.74	3372	0.392	0.154	-0.621	0.390	1.727	0.871
400T125-68	0.0713	0.462	1.57	1.150	0.541	1.577	0.061	0.363	1.150	0.517	10.22	3435	1.134	0.488	14.62	5205	0.783	0.194	-0.614	0.386	1.731	0.874
400T150-27	0.0283	0.198	0.67	0.509	0.246	1.602	0.042	0.461	0.409	0.154	3.04	515					0.053	0.127	-0.824	0.509	1.860	0.804
400T150-30	0.0312	0.218	0.74	0.561	0.271	1.603	0.046	0.461	0.458	0.183	3.61	689					0.071	0.140	-0.823	0.508	1.859	0.804
400T150-33	0.0346	0.242	0.82	0.622	0.300	1.603	0.051	0.460	0.519	0.208	4.12	940					0.097	0.155	-0.821	0.507	1.859	0.805
400T150-43	0.0451	0.315	1.07	0.811	0.390	1.604	0.066	0.458	0.719	0.293	5.80	1739					0.214	0.200	-0.817	0.504	1.857	0.807
400T150-54	0.0566	0.396	1.35	1.025	0.489	1.610	0.082	0.456	0.960	0.399	7.89	2739	0.918	0.374	11.19	3372	0.422	0.252	-0.811	0.501	1.860	0.810
400T150-68	0.0713	0.498	1.69	1.306	0.615	1.619	0.102	0.453	1.286	0.548	10.82	3435	1.237	0.513	15.35	5205	0.844	0.320	-0.804	0.496	1.864	0.814
400T200-33	0.0346	0.277	0.94	0.768	0.371	1.666	0.113	0.639	0.581	0.220	4.34	940					0.110	0.336	-1.229	0.737	2.166	0.678
400T200-43	0.0451	0.360	1.23	1.002	0.482	1.668	0.146	0.637	0.811	0.311	6.14	1739					0.244	0.436	-1.224	0.734	2.164	0.680
400T200-54	0.0566	0.452	1.54	1.268	0.604	1.675	0.182	0.635	1.093	0.426	8.42	2739	1.037	0.397	11.88	3372	0.483	0.551	-1.217	0.730	2.165	0.684
400T200-68	0.0713	0.569	1.94	1.617	0.761	1.685	0.227	0.632	1.485	0.591	11.68	3435	1.412	0.549	16.42	5205	0.965	0.702	-1.209	0.725	2.168	0.689
550T125-27	0.0283	0.226	0.77	0.948	0.336	2.046	0.027	0.348	0.786	0.192	3.79	372					0.060	0.160	-0.543	0.352	2.145	0.936
550T125-30	0.0312	0.250	0.85	1.045	0.370	2.046	0.030	0.347	0.897	0.226	4.47	499					0.081	0.176	-0.542	0.351	2.145	0.936
550T125-33	0.0346	0.277	0.94	1.159	0.410	2.046	0.033	0.346	1.029	0.270	5.33	680					0.110	0.195	-0.541	0.350	2.145	0.936
550T125-43	0.0451	0.360	1.23	1.510	0.533	2.047	0.043	0.344	1.428	0.416	8.23	1504					0.244	0.252	-0.537	0.348	2.144	0.937
550T125-54	0.0566	0.452	1.54	1.903	0.668	2.052	0.053	0.342	1.862	0.597	11.80	2739	1.811	0.535	16.01	2980	0.483	0.315	-0.532	0.345	2.147	0.939
550T125-68	0.0713	0.569	1.94	2.412	0.839	2.058	0.066	0.339	2.412	0.807	15.95	4347	2.379	0.769	23.02	5350	0.965	0.397	-0.526	0.341	2.152	0.940
550T150-27	0.0283	0.241	0.82	1.059	0.376	2.098	0.046	0.436	0.893	0.207	4.10	372					0.064	0.263	-0.716	0.456	2.259	0.900
550T150-30	0.0312	0.265	0.90	1.168	0.414	2.098	0.050	0.435	0.995	0.251	4.96	499					0.086	0.289	-0.715	0.455	2.259	0.900
550T150-33	0.0346	0.294	1.00	1.295	0.459	2.099	0.055	0.434	1.115	0.310	6.12	680					0.117	0.320	-0.714	0.455	2.259	0.900
550T150-43	0.0451	0.383	1.30	1.688	0.596	2.099	0.072	0.432	1.516	0.468	9.25	1504					0.260	0.414	-0.709	0.452	2.258	0.901
550T150-54	0.0566	0.480	1.63	2.128	0.747	2.105	0.089	0.430	2.005	0.628	12.41	2739	1.928	0.595	17.81	2980	0.513	0.519	-0.704	0.449	2.261	0.903
550T150-68	0.0713	0.605	2.06	2.699	0.939	2.112	0.110	0.427	2.660	0.850	16.80	4347	2.569	0.804	24.07	5350	1.025	0.655	-0.698	0.445	2.265	0.905
550T200-33	0.0346	0.329	1.12	1.567	0.555	2.184	0.123	0.613	1.246	0.307	6.06	680					0.131	0.694	-1.088	0.674	2.516	0.813
550T200-43	0.0451	0.428	1.46	2.043	0.722	2.185	0.160	0.611	1.690	0.495	9.79	1504					0.290	0.900	-1.083	0.671	2.514	0.814
550T200-54	0.0566	0.537	1.83	2.578	0.905	2.191	0.199	0.609	2.253	0.669	13.21	2739	2.153	0.63	18.86	2980	0.573	1.133	-1.077	0.668	2.517	0.817
550T200-68	0.0713	0.676	2.30	3.274	1.139	2.200	0.248	0.606	3.027	0.914	18.06	4347	2.894	0.857	25.67	5350	1.146	1.434	-1.070	0.663	2.521	0.820
600T125-27 <sup>1</sup>	0.0283	0.241	0.82	1.168	0.381	2.204	0.028	0.340	0.958	0.210	4.16	341					0.064	0.196	-0.519	0.339	2.290	0.949
600T125-30	0.0312	0.265	0.90	1.288	0.419	2.204	0.031	0.340	1.095	0.249	4.92	456					0.086	0.215	-0.518	0.338	2.289	0.949
600T125-33	0.0346	0.294	1.00	1.428	0.465	2.204	0.034	0.339	1.258	0.297	5.87	622					0.117	0.238	-0.516	0.337	2.289	0.949
600T125-43	0.0451	0.383	1.30	1.861	0.604	2.205	0.044	0.337	1.768	0.461	9.11	1377					0.260	0.307	-0.513	0.335	2.288	0.950
600T125-54	0.0566	0.480	1.63	2.344	0.756	2.209	0.054	0.335	2.299	0.666	13.15	2728	2.241	0.592	17.73	2728	0.513	0.384	-0.508	0.332	2.291	0.951
600T125-68	0.0713	0.605	2.06	2.969	0.950	2.215	0.067	0.332	2.969	0.916	18.09	4347	2.934	0.858	25.69</							

## Section Properties (Continued)

### Structural (T) Track Section Properties

Section	Design Thickness (in)	Gross Properties							Effective Properties (33ksi)				Effective 50ksi				Torsional					
		Area (in <sup>2</sup> )	Weight (lb/ft)	I <sub>x</sub> (in <sup>4</sup> )	S <sub>x</sub> (in <sup>3</sup> )	R <sub>x</sub> (in)	I <sub>y</sub> (in <sup>4</sup> )	R <sub>y</sub> (in)	I <sub>x</sub> (in <sup>4</sup> )	S <sub>x</sub> (in <sup>3</sup> )	Ma (in-k)	V <sub>ag</sub> (lb)	I <sub>xx</sub> (in <sup>4</sup> )	S <sub>xx</sub> (in <sup>3</sup> )	Ma (in-k)	V <sub>a</sub> (lb)	J <sup>x1000</sup> (in <sup>4</sup> )	C <sub>w</sub> (in <sup>6</sup> )	X <sub>o</sub> (in)	m (in)	R <sub>o</sub> (in)	β
600T200-54	0.0566	0.565	1.92	3.145	1.015	2.359	0.203	0.600	2.759	0.759	15.00	2728	2.641	0.717	21.48	2728	0.604	1.381	-1.038	0.649	2.646	0.846
600T200-68	0.0713	0.712	2.42	3.990	1.277	2.367	0.254	0.597	3.696	1.034	20.42	4347	3.54	0.973	29.12	5350	1.206	1.746	-1.031	0.644	2.650	0.849
600T200-97	0.1017	1.015	3.45	5.773	1.816	2.385	0.354	0.591	5.758	1.667	32.95	7359	5.558	1.568	46.94	10885	3.499	2.510	-1.016	0.635	2.659	0.854
800T125-33 <sup>1</sup>	0.0346	0.363	1.24	2.895	0.711	2.824	0.036	0.313	2.441	0.407	8.03	465					0.145	0.456	-0.439	0.294	2.875	0.977
800T125-43	0.0451	0.473	1.61	3.773	0.924	2.824	0.046	0.311	3.484	0.640	12.65	1030					0.321	0.589	-0.436	0.292	2.874	0.977
800T125-54	0.0566	0.594	2.02	4.745	1.158	2.827	0.057	0.309	4.668	0.940	18.58	2039	4.426	0.824	24.66	2039	0.634	0.735	-0.432	0.289	2.877	0.977
800T125-68	0.0713	0.748	2.54	5.998	1.454	2.833	0.070	0.306	5.998	1.356	26.80	4087	5.956	1.216	36.39	4087	1.267	0.920	-0.427	0.286	2.881	0.978
800T125-97	0.1017	1.066	3.63	8.613	2.062	2.843	0.096	0.301	8.613	2.062	40.74	8843	8.613	2.062	61.72	10885	3.674	1.296	-0.417	0.279	2.889	0.979
800T150-33 <sup>1</sup>	0.0346	0.380	1.29	3.180	0.781	2.891	0.060	0.397	2.569	0.414	8.18	465					0.152	0.751	-0.588	0.388	2.977	0.961
800T150-43	0.0451	0.496	1.69	4.144	1.015	2.891	0.077	0.395	3.689	0.655	12.95	1030					0.336	0.972	-0.584	0.386	2.976	0.961
800T150-54	0.0566	0.622	2.12	5.214	1.272	2.896	0.096	0.393	4.976	0.969	19.15	2039	4.692	0.844	25.27	2039	0.664	1.215	-0.580	0.383	2.979	0.962
800T150-68	0.0713	0.783	2.67	6.594	1.599	2.902	0.119	0.390	6.527	1.412	27.91	4087	6.361	1.255	37.58	4087	1.327	1.526	-0.575	0.379	2.984	0.963
800T150-97	0.1017	1.116	3.80	9.479	2.269	2.914	0.165	0.384	9.479	2.269	44.83	8843	9.479	2.192	65.62	10885	3.849	2.162	-0.564	0.372	2.993	0.965
800T200-33 <sup>1</sup>	0.0346	0.415	1.41	3.749	0.921	3.005	0.135	0.571	2.788	0.424	8.37	465					0.166	1.638	-0.917	0.589	3.194	0.918
800T200-43	0.0451	0.541	1.84	4.887	1.197	3.006	0.175	0.569	4.043	0.676	13.35	1030					0.367	2.124	-0.913	0.587	3.193	0.918
800T200-54	0.0566	0.679	2.31	6.152	1.501	3.011	0.218	0.567	5.505	1.009	19.93	2039	5.149	0.871	26.09	2039	0.725	2.664	-0.908	0.584	3.196	0.919
800T200-68	0.0713	0.854	2.91	7.786	1.888	3.019	0.272	0.564	7.306	1.490	29.45	4087	7.051	1.31	39.22	4087	1.448	3.357	-0.902	0.580	3.201	0.921
800T200-97	0.1017	1.218	4.15	11.212	2.683	3.034	0.379	0.558	11.176	2.491	49.22	8843	10.833	2.347	70.27	10885	4.200	4.792	-0.889	0.571	3.210	0.923
1000T125-43 <sup>1</sup>	0.0451	0.563	1.92	6.630	1.305	3.431	0.047	0.290	5.886	0.819	16.19	822					0.382	0.973	-0.379	0.259	3.464	0.988
1000T125-54	0.0566	0.707	2.41	8.333	1.634	3.434	0.059	0.288	7.960	1.216	24.03	1628	7.479	1.055	31.59	1628	0.755	1.212	-0.376	0.256	3.466	0.988
1000T125-68	0.0713	0.890	3.03	10.522	2.053	3.438	0.073	0.286	10.452	1.781	35.19	3261	10.155	1.575	47.15	3261	1.508	1.515	-0.372	0.253	3.470	0.989
1000T125-97	0.1017	1.269	4.32	15.077	2.912	3.447	0.100	0.280	15.077	2.907	57.44	8843	15.077	2.753	82.42	9507	4.375	2.123	-0.363	0.247	3.477	0.989
1000T150-43 <sup>1</sup>	0.0451	0.586	1.99	7.207	1.419	3.507	0.080	0.370	6.195	0.837	16.54	822					0.397	1.612	-0.513	0.345	3.564	0.979
1000T150-54	0.0566	0.735	2.50	9.061	1.777	3.511	0.100	0.368	8.430	1.249	24.69	1628	7.88	1.079	32.29	1628	0.785	2.013	-0.509	0.342	3.567	0.980
1000T150-68	0.0713	0.926	3.15	11.445	2.233	3.516	0.124	0.366	11.342	1.846	36.48	3261	10.774	1.621	48.53	3261	1.569	2.522	-0.505	0.339	3.571	0.980
1000T150-97	0.1017	1.320	4.49	16.413	3.170	3.526	0.171	0.360	16.413	3.165	62.54	8843	16.413	2.902	86.9	9507	4.550	3.557	-0.495	0.332	3.579	0.981
1000T200-43 <sup>1</sup>	0.0451	0.631	2.15	8.361	1.646	3.640	0.183	0.539	6.722	0.861	17.01	822					0.428	3.540	-0.813	0.534	3.769	0.953
1000T200-54	0.0566	0.792	2.69	10.516	2.062	3.645	0.228	0.537	9.231	1.295	25.60	1628	8.56	1.111	33.26	1628	0.845	4.434	-0.809	0.531	3.772	0.954
1000T200-68	0.0713	0.997	3.39	13.292	2.594	3.651	0.284	0.534	12.551	1.936	38.26	3261	11.82	1.684	50.42	3261	1.690	5.576	-0.803	0.527	3.776	0.955
1000T200-97	0.1017	1.422	4.84	19.087	3.686	3.664	0.397	0.528	19.031	3.427	67.72	8843	18.583	3.081	92.25	9507	4.901	7.924	-0.791	0.519	3.786	0.956
1200T125-54 <sup>1</sup>	0.0566	0.820	2.79	13.335	2.186	4.033	0.060	0.271	12.296	1.491	29.47	1354	11.46	1.286	38.51	1354	0.876	1.820	-0.333	0.230	4.055	0.993
1200T125-68	0.0713	1.033	3.51	16.826	2.747	4.036	0.074	0.268	16.246	2.206	43.60	2713	15.686	1.934	57.9	2713	1.750	2.270	-0.329	0.227	4.059	0.993
1200T125-97	0.1017	1.472	5.01	24.078	3.897	4.044	0.102	0.263	24.078	3.690	72.92	7902	23.751	3.442	103.06	7902	5.076	3.171	-0.322	0.222	4.065	0.994
1200T150-54 <sup>1</sup>	0.0566	0.848	2.89	14.378	2.357	4.117	0.103	0.348	12.962	1.530	30.23	1354	12.02	1.313	39.31	1354	0.906	3.033	-0.454	0.310	4.156	0.988
1200T150-68	0.0713	1.068	3.64	18.148	2.963	4.121	0.127	0.345	17.568	2.281	45.08	2713	16.566	1.987	59.48	2713	1.810	3.795	-0.450	0.307	4.160	0.988
1200T150-97	0.1017	1.523	5.18	25.987	4.206	4.130	0.176	0.340	25.987	3.996	78.97	7902	25.719	3.616	108.27	7902	5.252	5.335	-0.441	0.301	4.168	0.989
1200T200-54 <sup>1</sup>	0.0566	0.905	3.08	16.464	2.699	4.265	0.236	0.510	14.078	1.582	31.26	1354	12.962	1.35	40.41	1354	0.966	6.714	-0.730	0.487	4.357	0.972
1200T200-68	0.0713	1.140	3.88	20.791	3.395	4.271	0.294	0.508	19.277	2.383	47.09	2713	18.026	2.058	61.62	2713	1.931	8.431	-0.725	0.483	4.362	0.972
1200T200-97	0.1017	1.625	5.53	29.805	4.824	4.283	0.410	0.502	29.805	4.298	84.93	7902	28.959	3.819	114.35	7902	5.602	11.945	-0.714	0.476	4.371	0.973

## Allowable Floor and Roof Joist Span Data

Member	Fy (ksi)	Floor and Roof Joist Span Tables																	
		Allowable Uniform Load Table (plf) - Simple Span Joists																	
		Span (ft)																	
			6'-0"	7'-0"	8'-0"	9'-0"	10'-0"	11'-0"	12'-0"	13'-0"	14'-0"	15'-0"	16'-0"	17'-0"	18'-0"	19'-0"	20'-0"	22'-0"	24'-0"
600S162-33	33	Total Load	168	124	95	75	61	50	42	36	31	27	24	21	19	17	15	13	11
		Live Load	168	124	95	75	61	50	42	36	29	23	19	16	13	11	10	7	6
600S200-33	33		193	142	109	86	70	57	48	41	35	31	27	24	21	19	17	14	12
			193	142	109	86	70	57	48	41	33	27	22	18	15	13	11	8	7
600S162-43	33		252	185	142	112	91	75	63	54	46	40	35	31	28	25	23	19	16
			252	185	142	112	91	75	59	46	37	30	25	21	17	15	13	10	7
600S200-43	33		276	203	155	123	99	82	69	59	51	44	39	34	31	27	25	21	17
			276	203	155	123	99	82	68	53	43	35	29	24	20	17	15	11	8
600S250-43	33		291	214	164	129	105	87	73	62	53	47	41	36	32	29	26	22	18
			291	214	164	129	105	87	73	61	49	40	33	27	23	20	17	13	10
600S162-54	50		426	313	240	189	153	127	107	91	78	68	60	53	47	43	38	32	27
			426	313	240	172	125	94	72	57	46	37	31	25	21	18	16	12	9
600S200-54	50		487	358	274	217	175	145	122	104	90	78	69	61	54	49	44	36	30
			487	358	274	199	145	109	84	66	53	43	35	30	25	21	18	14	10
600S250-54	50		513	377	289	228	185	153	128	109	94	82	72	64	57	51	46	38	32
			513	377	289	226	165	124	95	75	60	49	40	34	28	24	21	15	12
600S162-68	50		612	450	344	272	220	182	153	130	112	98	86	76	68	61	55	46	38
			612	449	301	211	154	116	89	70	56	46	38	31	26	22	19	14	11
600S200-68	50		657	483	370	292	237	195	164	140	121	105	92	82	73	66	59	49	41
			657	483	350	246	179	135	104	82	65	53	44	36	31	26	22	17	13
600S250-68	50		697	512	392	310	251	207	174	148	128	111	98	87	77	69	63	52	44
			697	512	392	283	207	155	120	94	75	61	50	42	35	30	26	19	15
600S162-97	50		1005	738	565	447	362	299	251	214	185	161	141	125	112	100	90	75	63
			971	612	410	288	210	158	121	95	76	62	51	43	36	31	26	20	15
600S200-97	50		1127	828	634	501	406	335	282	240	207	180	158	140	125	112	101	84	70
			1127	715	479	337	245	184	142	112	89	73	60	50	42	36	31	23	18
600S250-97	50		1096	805	616	487	395	326	274	233	201	175	154	137	122	109	99	82	68
			1096	805	555	390	284	213	164	129	104	84	69	58	49	41	36	27	21
600S162-118	50		1207 a	933	714	564	457	378	317	271	233	203	179	158	141	127	114	94	79
			1145 a	721	483	339	247	186	143	113	90	73	60	50	42	36	31	23	18
600S200-118	50		1207 a	1035 a	811	641	519	429	361	307	265	231	203	180	160	144	130	107	90
			1207 a	847 a	567	398	290	218	168	132	106	86	71	59	50	42	36	27	21

### General Notes

- All loads are computed in accordance with AISI S100-16, NAS for Design of Cold-Formed Steel Structural Members with Supplement 2.
- Total loads shown are for single span condition and are limited by allowable bending stress or allowable end shear. Live loads shown are limited by allowable bending stress, allowable end shear, or by deflection on 1/360 of span.
- Total load values in table are based on maximum allowable stress only. To limit total load deflection to 1/240 of span, multiply live load value shown by 1.5.
- For two equal continuous spans, the total load shown in these tables will not change. The live load shown may be increased by a factor of 2.4 to maintain the L/360 live load deflection limit, however live load, in any case, cannot exceed the total load shown. Combined bending and shear stresses should be investigated by the designer.
- Joists must be braced against rotation at all supports.
- End web crippling check is based on 3.5 inch end bearing. Joist flanges must be fastened to the support.
- Spans are based on continuous support of compression flange over the full length of the joist.
- End shear and web crippling capacity have not been reduced for punchouts.
- “ a “ indicates that web stiffeners are required at all supports.
- Allowable flexural strength values in the tables are based on the minimum of local, distortional, and lateral-torsional buckling. Distortional buckling strength is based on a  $k\phi = 0$ . Higher values may be obtained when sheathing is applied to the walls resulting in a higher k-phi value.

### LEED Green Building Credits

- MR Credit 2: Construction Waste Management – MBA steel framing is 100% recyclable.
- MR Credit 4: Recycled Content – MBA steel framing is formed from no less than 25.5% post-consumer and 6.8% pre-consumer recycled content.
- MR Credit 5: Regional Materials – MBA has manufacturing facilities in multiple states.

## Allowable Floor and Roof Joist Span Data

Member	Fy (ksi)		Floor and Roof Joist Span Tables																
			Allowable Uniform Load Table (plf) - Simple Span Joists																
			Span (ft)																
			6'-0"	7'-0"	8'-0"	9'-0"	10'-0"	11'-0"	12'-0"	13'-0"	14'-0"	15'-0"	16'-0"	17'-0"	18'-0"	19'-0"	20'-0"	22'-0"	24'-0"
600S250-118	50	Total Load	1207	a 1026	785	620	503	415	349	297	256	223	196	174	155	139	126	104	87
		Live Load	1207	a 983	659	463	337	253	195	154	123	100	82	69	58	49	42	32	24
800S162-33	33		126	a 108	a 95	a 84	68	56	47	40	35	30	26	23	21	19	17	14	12
			126	a 108	a 95	a 84	68	56	47	40	35	30	26	23	21	19	17	14	11
800S200-33	33		126	a 108	a 95	a 84	a 76	a 65	54	46	40	35	31	27	24	22	20	16	14
			126	a 108	a 95	a 84	a 76	a 65	54	46	40	35	31	27	24	22	20	16	13
800S162-43	33		326	240	184	145	117	97	82	70	60	52	46	41	36	33	29	24	20
			326	240	184	145	117	97	82	70	60	52	46	40	34	29	25	18	14
800S200-43	33		350	a 277	212	167	136	112	94	80	69	60	53	47	42	38	34	28	24
			350	a 277	212	167	136	112	94	80	69	60	53	47	40	34	29	22	17
800S250-43	33		350	a 291	223	176	143	118	99	84	73	63	56	49	44	40	36	29	25
			350	a 291	223	176	143	118	99	84	73	63	56	49	44	38	33	25	19
800S162-54	50		580	426	326	258	209	173	145	124	107	93	82	72	64	58	52	43	36
			580	426	326	258	209	173	142	112	89	73	60	50	42	36	31	23	18
800S200-54	50		667	490	375	296	240	198	167	142	122	107	94	83	74	67	60	50	42
			667	490	375	296	240	198	166	131	105	85	70	58	49	42	36	27	21
800S250-54	50		697	a 515	394	311	252	208	175	149	129	112	99	87	78	70	63	52	44
			697	a 515	394	311	252	208	175	147	118	96	79	66	55	47	40	30	23

### General Notes

- All loads are computed in accordance with AISI S100-16, NAS for Design of Cold-Formed Steel Structural Members with Supplement 2.
- Total loads shown are for single span condition and are limited by allowable bending stress or allowable end shear. Live loads shown are limited by allowable bending stress, allowable end shear, or by deflection on 1/360 of span.
- Total load values in table are based on maximum allowable stress only. To limit total load deflection to 1/240 of span, multiply live load value shown by 1.5.
- For two equal continuous spans, the total load shown in these tables will not change. The live load shown may be increased by a factor of 2.4 to maintain the L/360 live load deflection limit, however live load, in any case, cannot exceed the total load shown. Combined bending and shear stresses should be investigated by the designer.
- Joists must be braced against rotation at all supports.
- End web crippling check is based on 3.5 inch end bearing. Joist flanges must be fastened to the support.
- Spans are based on continuous support of compression flange over the full length of the joist.
- End shear and web crippling capacity have not been reduced for punchouts.
- “ a “ indicates that web stiffeners are required at all supports.
- Allowable flexural strength values in the tables are based on the minimum of local, distortional, and lateral-torsional buckling. Distortional buckling strength is based on a  $k\phi = 0$ . Higher values may be obtained when sheathing is applied to the walls resulting in a higher k-phi value.

### LEED Green Building Credits

- MR Credit 2: Construction Waste Management – MBA steel framing is 100% recyclable.
- MR Credit 4: Recycled Content – MBA steel framing is formed from no less than 25.5% post-consumer and 6.8% pre-consumer recycled content.
- MR Credit 5: Regional Materials – MBA has manufacturing facilities in multiple states.

## Allowable Floor and Roof Joist Span Data

Member	Fy (ksi)		Floor and Roof Joist Span Tables																
			Allowable Uniform Load Table (plf) - Simple Span Joists @ 24" o.c. Spacing																
			Span (ft)																
			6'-0"	7'-0"	8'-0"	9'-0"	10'-0"	11'-0"	12'-0"	13'-0"	14'-0"	15'-0"	16'-0"	17'-0"	18'-0"	19'-0"	20'-0"	22'-0"	24'-0"
800S162-68	50	Total Load	794	584	447	353	286	236	199	169	146	127	112	99	88	79	71	59	50
		Live Load	794	584	447	353	286	232	179	141	113	92	75	63	53	45	39	29	22
800S200-68	50		910	668	512	404	328	271	227	194	167	146	128	113	101	91	82	68	57
			910	668	512	404	328	267	206	162	130	105	87	72	61	52	44	33	26
800S250-68	50		960	705	540	427	346	286	240	205	176	154	135	120	107	96	86	71	60
			960	705	540	427	346	286	234	184	147	120	99	82	69	59	51	38	29
800S162-97	50		1385	1017	779	615	498	412	346	295	254	222	195	172	154	138	125	103	87
			1385	1017	779	583	425	319	246	193	155	126	104	86	73	62	53	40	31
800S200-97	50		1589	1168	894	706	572	473	397	339	292	254	224	198	177	159	143	118	99
			1589	1168	894	672	490	368	283	223	178	145	120	100	84	71	61	46	35
800S250-97	50		1537	1129	865	683	553	457	384	327	282	246	216	192	171	153	138	114	96
			1537	1129	865	683	553	420	324	254	204	166	136	114	96	82	70	53	40
800S162-118	50		1868	1372	1051	830	672	556	467	398	343	299	263	233	208	186	168	139	117
			1868	1372	983	690	503	378	291	229	183	149	123	102	86	73	63	47	36
800S200-118	50		2080	1528	1170	925	749	619	520	443	382	333	293	259	231	207	187	155	130
			2080	1528	1137	799	582	437	337	265	212	173	142	119	100	85	73	55	42
800S250-118	50		1982	1456	1115	881	714	590	496	422	364	317	279	247	220	198	178	147	124
			1982	1456	1115	881	666	501	386	303	243	197	163	136	114	97	83	63	48

### General Notes

- All loads are computed in accordance with AISI S100-16, NAS for Design of Cold-Formed Steel Structural Members with Supplement 2.
- Total loads shown are for single span condition and are limited by allowable bending stress or allowable end shear. Live loads shown are limited by allowable bending stress, allowable end shear, or by deflection on 1/360 of span.
- Total load values in table are based on maximum allowable stress only. To limit total load deflection to 1/240 of span, multiply live load value shown by 1.5.
- For two equal continuous spans, the total load shown in these tables will not change. The live load shown may be increased by a factor of 2.4 to maintain the L/360 live load deflection limit, however live load, in any case, cannot exceed the total load shown. Combined bending and shear stresses should be investigated by the designer.
- Joists must be braced against rotation at all supports.
- End web crippling check is based on 3.5 inch end bearing. Joist flanges must be fastened to the support.
- Spans are based on continuous support of compression flange over the full length of the joist.
- End shear and web crippling capacity have not been reduced for punchouts.
- " a " indicates that web stiffeners are required at all supports.
- Allowable flexural strength values in the tables are based on the minimum of local, distortional, and lateral-torsional buckling. Distortional buckling strength is based on a  $k\phi = 0$ . Higher values may be obtained when sheathing is applied to the walls resulting in a higher k-phi value.

### LEED Green Building Credits

- MR Credit 2: Construction Waste Management – MBA steel framing is 100% recyclable.
- MR Credit 4: Recycled Content – MBA steel framing is formed from no less than 25.5% post-consumer and 6.8% pre-consumer recycled content.
- MR Credit 5: Regional Materials – MBA has manufacturing facilities in multiple states.

## Allowable Floor and Roof Joist Span Data

Member	Fy (ksi)		Floor and Roof Joist Span Tables																
			Allowable Uniform Load Table (plf) - Simple Span Joists @ 24" o.c. Spacing																
			Span (ft)																
			11'-0"	12'-0"	13'-0"	14'-0"	15'-0"	16'-0"	17'-0"	18'-0"	19'-0"	20'-0"	22'-0"	24'-0"	26'-0"	28'-0"	30'-0"	32'-0"	34'-0"
1000S162-431	33	Total Load	100	84	71	62	54	47	42	37	33	30	25	21	18	15	13	12	10
		Live Load	100	84	71	62	54	47	42	37	33	30	25	21	18	15	12	10	8
1000S200-431	33		117	98	84	72	63	55	49	44	39	35	29	25	21	18	16	14	12
			117	98	84	72	63	55	49	44	39	35	29	25	21	17	14	11	10
1000S250-431	33		122 a	104	88	76	66	58	52	46	41	37	31	26	22	19	17	15	13
			122 a	104	88	76	66	58	52	46	41	37	31	26	22	19	17	14	11
1000S162-54	50		213	179	153	132	115	101	89	80	71	64	53	45	38	33	29	25	22
			213	179	153	132	115	100	84	71	60	51	39	30	23	19	15	13	10
1000S200-54	50		248	209	178	153	134	117	104	93	83	75	62	52	44	38	33	29	26
			248	209	178	153	134	115	96	81	69	59	44	34	27	21	17	14	12
1000S250-54	50		263	221	188	162	141	124	110	98	88	79	66	55	47	41	35	31	27
			263	221	188	162	141	124	110	95	81	69	52	40	32	25	21	17	14
1000S162-68	50		296	249	212	183	159	140	124	111	99	90	74	62	53	46	40	35	31
			296	249	212	183	155	128	107	90	76	65	49	38	30	24	19	16	13
1000S200-68	50		342	288	245	211	184	162	143	128	115	104	86	72	61	53	46	40	36
			342	288	245	211	177	146	122	102	87	75	56	43	34	27	22	18	15
1000S250-68	50		363	305	260	224	195	172	152	136	122	110	91	76	65	56	49	43	38
			363	305	260	224	195	168	140	118	100	86	65	50	39	31	25	21	18
1000S162-97	50		483	406	346	298	260	228	202	180	162	146	121	102	86	75	65	57	51
			483	406	338	270	220	181	151	127	108	93	70	54	42	34	27	23	19
1000S200-97	50		554	465	396	342	298	262	232	207	186	167	138	116	99	85	74	65	58
			554	465	385	308	250	206	172	145	123	106	79	61	48	39	31	26	22
1000S250-97	50		590	496	423	364	317	279	247	220	198	179	148	124	106	91	79	70	62
			590	496	423	348	283	233	194	164	139	119	90	69	54	43	35	29	24
1000S162-118	50		664	558	476	410	357	314	278	248	223	201	166	140	119	103	89	78	70
			663	510	401	321	261	215	179	151	129	110	83	64	50	40	33	27	22
1000S200-118	50		759	638	543	469	408	359	318	283	254	230	190	159	136	117	102	90	79
			757	583	459	367	299	246	205	173	147	126	95	73	57	46	37	31	26
1000S250-118	50		769	646	551	475	414	364	322	287	258	233	192	162	138	119	103	91	81
			769	646	519	416	338	278	232	195	166	143	107	82	65	52	42	35	29

### General Notes

- All loads are computed in accordance with AISI S100-16, NAS for Design of Cold-Formed Steel Structural Members with Supplement 2.
- Total loads shown are for single span condition and are limited by allowable bending stress or allowable end shear. Live loads shown are limited by allowable bending stress, allowable end shear, or by deflection on 1/360 of span.
- Total load values in table are based on maximum allowable stress only. To limit total load deflection to 1/240 of span, multiply live load value shown by 1.5.
- For two equal continuous spans, the total load shown in these tables will not change. The live load shown may be increased by a factor of 2.4 to maintain the L/360 live load deflection limit, however live load, in any case, cannot exceed the total load shown. Combined bending and shear stresses should be investigated by the designer.
- Joists must be braced against rotation at all supports.
- End web crippling check is based on 3.5 inch end bearing. Joist flanges must be fastened to the support.
- Spans are based on continuous support of compression flange over the full length of the joist.
- End shear and web crippling capacity have not been reduced for punchouts.
- “ a “ indicates that web stiffeners are required at all supports.
- Allowable flexural strength values in the tables are based on the minimum of local, distortional, and lateral-torsional buckling. Distortional buckling strength is based on a  $k\phi = 0$ . Higher values may be obtained when sheathing is applied to the walls resulting in a higher k-phi value.

### LEED Green Building Credits

- MR Credit 2: Construction Waste Management – MBA steel framing is 100% recyclable.
- MR Credit 4: Recycled Content – MBA steel framing is formed from no less than 25.5% post-consumer and 6.8% pre-consumer recycled content.
- MR Credit 5: Regional Materials – MBA has manufacturing facilities in multiple states.

## Allowable Floor and Roof Joist Span Data

Member	Fy (ksi)		Floor and Roof Joist Span Tables																
			Allowable Uniform Load Table (plf) - Simple Span Joists @ 24" o.c. Spacing																
			Span (ft)																
			11'-0"	12'-0"	13'-0"	14'-0"	15'-0"	16'-0"	17'-0"	18'-0"	19'-0"	20'-0"	22'-0"	24'-0"	26'-0"	28'-0"	30'-0"	32'-0"	34'-0"
1400S300-54	50	Total Load	171 <sup>a</sup>	157 <sup>a</sup>	145 <sup>a</sup>	134 <sup>a</sup>	125 <sup>a</sup>	118 <sup>a</sup>	111 <sup>a</sup>	105 <sup>a</sup>	99 <sup>a</sup>	94 <sup>a</sup>	78	65	56	48	42	37	33
		Live Load	171 <sup>a</sup>	157 <sup>a</sup>	145 <sup>a</sup>	134 <sup>a</sup>	125 <sup>a</sup>	118 <sup>a</sup>	111 <sup>a</sup>	105 <sup>a</sup>	99 <sup>a</sup>	94 <sup>a</sup>	78	65	56	48	42	36	30
1400S200-68	50		430 <sup>a</sup>	390	332	287	250	219	194	173	156	140	116	98	83	72	62	55	49
			430 <sup>a</sup>	390	332	287	250	219	194	173	156	140	116	94	74	59	48	40	33
1400S250-68	50		430 <sup>a</sup>	394 <sup>a</sup>	359	310	270	237	210	187	168	152	125	105	90	77	67	59	53
			430 <sup>a</sup>	394 <sup>a</sup>	359	310	270	237	210	187	168	152	125	105	84	67	54	45	37
1400S300-68	50		430 <sup>a</sup>	394 <sup>a</sup>	364 <sup>a</sup>	325	283	249	220	196	176	159	131	110	94	81	71	62	55
			430 <sup>a</sup>	394 <sup>a</sup>	364 <sup>a</sup>	325	283	249	220	196	176	159	131	110	91	73	59	49	41
1400S200-97	50		778	654	557	480	419	368	326	291	261	235	195	163	139	120	105	92	81
			778	654	557	480	419	368	326	291	261	235	179	138	109	87	71	58	49
1400S250-97	50		840	706	602	519	452	397	352	314	282	254	210	177	150	130	113	99	88
			840	706	602	519	452	397	352	314	282	254	200	154	121	97	79	65	54
1400S300-97	50		883	742	632	545	475	417	370	330	296	267	221	185	158	136	119	104	92
			883	742	632	545	475	417	370	330	296	267	219	169	133	106	86	71	59
1400S200-111	50		1032	867	739	637	555	488	432	385	346	312	258	217	185	159	139	122	108
			1032	867	739	637	555	488	432	385	341	293	220	169	133	107	87	71	60
1400S250-111	50		1116	938	799	689	600	528	467	417	374	338	279	235	200	172	150	132	117
			1116	938	799	689	600	528	467	417	374	325	244	188	148	119	96	79	66
1400S300-111	50		1175	988	842	726	632	556	492	439	394	356	294	247	210	181	158	139	123
			1175	988	842	726	632	556	492	439	394	356	269	207	163	131	106	87	73
1600S200-68	50		300 <sup>a</sup>	275 <sup>a</sup>	254 <sup>a</sup>	236 <sup>a</sup>	220 <sup>a</sup>	203	180	160	144	130	107	90	77	66	58	51	45
			300 <sup>a</sup>	275 <sup>a</sup>	254 <sup>a</sup>	236 <sup>a</sup>	220 <sup>a</sup>	203	180	160	144	130	107	90	77	66	58	51	45
1600S250-68	50		300 <sup>a</sup>	275 <sup>a</sup>	254 <sup>a</sup>	236 <sup>a</sup>	220 <sup>a</sup>	206 <sup>a</sup>	194 <sup>a</sup>	175	157	142	117	98	84	72	63	55	49
			300 <sup>a</sup>	275 <sup>a</sup>	254 <sup>a</sup>	236 <sup>a</sup>	220 <sup>a</sup>	206 <sup>a</sup>	194 <sup>a</sup>	175	157	142	117	98	84	72	63	55	49
1600S300-68	50		300 <sup>a</sup>	275 <sup>a</sup>	254 <sup>a</sup>	236 <sup>a</sup>	220 <sup>a</sup>	206 <sup>a</sup>	194 <sup>a</sup>	183 <sup>a</sup>	166	150	124	104	88	76	66	58	52
			300 <sup>a</sup>	275 <sup>a</sup>	254 <sup>a</sup>	236 <sup>a</sup>	220 <sup>a</sup>	206 <sup>a</sup>	194 <sup>a</sup>	183 <sup>a</sup>	166	150	124	104	88	76	66	58	52
1600S350-68	50		300 <sup>a</sup>	275 <sup>a</sup>	254 <sup>a</sup>	236 <sup>a</sup>	220 <sup>a</sup>	206 <sup>a</sup>	194 <sup>a</sup>	183 <sup>a</sup>	174 <sup>a</sup>	165 <sup>a</sup>	150 <sup>a</sup>	130	111	96	83	73	65
			300 <sup>a</sup>	275 <sup>a</sup>	254 <sup>a</sup>	236 <sup>a</sup>	220 <sup>a</sup>	206 <sup>a</sup>	194 <sup>a</sup>	183 <sup>a</sup>	174 <sup>a</sup>	165 <sup>a</sup>	150 <sup>a</sup>	130	111	96	83	73	64
1600S200-97	50		874	734	626	539	470	413	366	326	293	264	218	184	156	135	117	103	91
			874	734	626	539	470	413	366	326	293	264	218	184	149	119	97	80	67
1600S250-97	50		951	799	681	587	511	450	398	355	319	288	238	200	170	147	128	112	100
			951	799	681	587	511	450	398	355	319	288	238	200	166	133	108	89	74

### General Notes

- All loads are computed in accordance with AISI S100-16, NAS for Design of Cold-Formed Steel Structural Members with Supplement 2.
- Total loads shown are for single span condition and are limited by allowable bending stress or allowable end shear. Live loads shown are limited by allowable bending stress, allowable end shear, or by deflection on 1/360 of span.
- Total load values in table are based on maximum allowable stress only. To limit total load deflection to 1/240 of span, multiply live load value shown by 1.5.
- For two equal continuous spans, the total load shown in these tables will not change. The live load shown may be increased by a factor of 2.4 to maintain the L/360 live load deflection limit, however live load, in any case, cannot exceed the total load shown. Combined bending and shear stresses should be investigated by the designer.
- Joists must be braced against rotation at all supports.
- End web crippling check is based on 3.5 inch end bearing. Joist flanges must be fastened to the support.
- Spans are based on continuous support of compression flange over the full length of the joist.
- End shear and web crippling capacity have not been reduced for punchouts.
- “ a “ indicates that web stiffeners are required at all supports.
- Allowable flexural strength values in the tables are based on the minimum of local, distortional, and lateral-torsional buckling. Distortional buckling strength is based on a  $k\phi = 0$ . Higher values may be obtained when sheathing is applied to the walls resulting in a higher k-phi value.

### LEED Green Building Credits

- MR Credit 2: Construction Waste Management – MBA steel framing is 100% recyclable.
- MR Credit 4: Recycled Content – MBA steel framing is formed from no less than 25.5% post-consumer and 6.8% pre-consumer recycled content.
- MR Credit 5: Regional Materials – MBA has manufacturing facilities in multiple states.

## Allowable Floor and Roof Joist Span Data

Member	Fy (ksi)		Floor and Roof Joist Span Tables																
			Allowable Uniform Load Table (plf) - Simple Span Joists																
			Span (ft)																
			6'-0"	7'-0"	8'-0"	9'-0"	10'-0"	11'-0"	12'-0"	13'-0"	14'-0"	15'-0"	16'-0"	17'-0"	18'-0"	19'-0"	20'-0"	22'-0"	24'-0"
600S162-33	33	Total Load	168	124	95	75	61	50	42	36	31	27	24	21	19	17	15	13	11
		Live Load	168	124	95	75	61	50	42	36	29	23	19	16	13	11	10	7	6
600S200-33	33		193	142	109	86	70	57	48	41	35	31	27	24	21	19	17	14	12
			193	142	109	86	70	57	48	41	33	27	22	18	15	13	11	8	7
600S162-43	33		252	185	142	112	91	75	63	54	46	40	35	31	28	25	23	19	16
			252	185	142	112	91	75	59	46	37	30	25	21	17	15	13	10	7
600S200-43	33		276	203	155	123	99	82	69	59	51	44	39	34	31	27	25	21	17
			276	203	155	123	99	82	68	53	43	35	29	24	20	17	15	11	8
600S250-43	33		291	214	164	129	105	87	73	62	53	47	41	36	32	29	26	22	18
			291	214	164	129	105	87	73	61	49	40	33	27	23	20	17	13	10
600S162-54	50		426	313	240	189	153	127	107	91	78	68	60	53	47	43	38	32	27
			426	313	240	172	125	94	72	57	46	37	31	25	21	18	16	12	9

### General Notes

1. All loads are computed in accordance with AISI S100-16, NAS for Design of Cold-Formed Steel Structural Members with Supplement 2.
2. Total loads shown are for single span condition and are limited by allowable bending stress or allowable end shear. Live loads shown are limited by allowable bending stress, allowable end shear, or by deflection on 1/360 of span.
3. Total load values in table are based on maximum allowable stress only. To limit total load deflection to 1/240 of span, multiply live load value shown by 1.5.
4. For two equal continuous spans, the total load shown in these tables will not change. The live load shown may be increased by a factor of 2.4 to maintain the L/360 live load deflection limit, however live load, in any case, cannot exceed the total load shown. Combined bending and shear stresses should be investigated by the designer.
5. Joists must be braced against rotation at all supports.
6. End web crippling check is based on 3.5 inch end bearing. Joist flanges must be fastened to the support.
7. Spans are based on continuous support of compression flange over the full length of the joist.
8. End shear and web crippling capacity have not been reduced for punchouts.
9. "a" indicates that web stiffeners are required at all supports.
10. Allowable flexural strength values in the tables are based on the minimum of local, distortional, and lateral-torsional buckling. Distortional buckling strength is based on a  $k\phi = 0$ . Higher values may be obtained when sheathing is applied to the walls resulting in a higher k-phi value.

### LEED Green Building Credits

- MR Credit 2: Construction Waste Management – MBA steel framing is 100% recyclable.
- MR Credit 4: Recycled Content – MBA steel framing is formed from no less than 25.5% post-consumer and 6.8% pre-consumer recycled content.
- MR Credit 5: Regional Materials – MBA has manufacturing facilities in multiple states.

## Curtain Wall – Table Notes

1. Lateral loads have not been modified for strength checks: full loads are applied.
2. Calculated properties are based on AISI S100-16/52-20, "North American Specification for Cold-Formed Steel Structural Members."
3. For 15 psf or higher wind pressure, read the note below.

IBC 2021/ASCE 7-16: Due to the change in the model building codes, design wind pressures determined using IBC 2021/ASCE 7-16 are strength level loads (LRFD) in comparison to those determined in earlier IBC codes which were service level loads (ASD). The load/span tables that follow are based on service level (ASD) wind loads. Therefore, to properly use the load/span tables in this catalog, multiply the IBC 2021/ASCE 7-16 design wind pressures by 0.6 (Reference section 2.4 ASCE 7-16) prior to entering the load/span tables.

-Example:

- \* ASCE 7-16 Calculated Design Wind Pressure = 25 psf (Strength level loads, LRFD)
- \* Convert to service level loads (ASD) = 25 psf x 0.6 = 15 psf
- \* Use 15 psf as the Pressure Value used in this Table to determine the member span

Any Other Building Code: The load/span tables that follow are based on service level (ASD) wind loads. If the wind load being used meets this criterion, it does not need to be modified prior to using the tables.

4. For 15 psf and higher wind pressures have been multiplied by 0.7 x ASD loads, or 0.42 x Ultimate loads for deflection determination, in accordance with footnote "f" of IBC Table 1604.3. The 5 psf live load has not been reduced for deflection checks.
5. Limiting heights are based on continuous support of each flange over the full length of the stud.
6. Limiting heights are based on steel properties alone (non-composite).
7. Web crippling checks are based on end-one flange loading condition using 1-inch end bearing.
8. End shear and web crippling capacity have not been reduced for punchouts. Punchouts are assumed to be at least 10-inches to centered no less than 12 inches from the end of members, in accordance with AISI 5240-20, Section A5.9.
9. Where limiting heights are followed by "e": web stiffeners are required.

Stud Member	Spacing	Fy (ksi)	5 psf			15 psf			20 psf			25 psf			30 psf			
			L/120	L/240	L/360	L/120	L/240	L/360	L/120	L/240	L/360	L/120	L/240	L/360	L/120	L/240	L/360	L/120
250S137-33	12	33	17'-6"	13'-10"	12'-1"	10'-10"	9'-5"	8'-0"	9'-10"	8'-7"	7'-3"	9'-1"	8'-0"	6'-9"	8'-3"	7'-6"	6'-4"	7'-8"
	16		15'-10"	12'-7"	11'-0"	9'-10"	8'-7"	7'-3"	8'-10"	7'-10"	6'-7"	7'-10"	7'-3"	6'-1"	7'-2"	6'-10"	5'-9"	6'-8"
	24		13'-10"	11'-0"	9'-7"	8'-3"	7'-6"	6'-4"	7'-2"	6'-10"	5'-9"	6'-5"	6'-4"	5'-4"	5'-10"	5'-0"	5'-5"	5'-8"
250S137-43	12	33	19'-0"	15'-1"	13'-2"	11'-9"	10'-3"	8'-8"	10'-8"	9'-4"	7'-10"	9'-11"	8'-8"	7'-4"	9'-4"	8'-2"	6'-11"	8'-10"
	16		17'-3"	13'-8"	11'-11"	10'-8"	9'-4"	7'-10"	9'-9"	8'-6"	7'-2"	9'-0"	7'-10"	6'-8"	8'-5"	7'-5"	6'-3"	7'-10"
	24		15'-1"	11'-11"	10'-5"	9'-4"	8'-2"	6'-11"	8'-5"	7'-5"	6'-3"	7'-6"	6'-11"	5'-10"	6'-10"	6'-6"	5'-6"	6'-4"
250S137-54	12	33	20'-3"	16'-1"	14'-1"	12'-7"	11'-0"	9'-3"	11'-5"	10'-0"	8'-5"	10'-7"	9'-3"	7'-10"	10'-0"	8'-9"	7'-4"	9'-6"
	16		18'-5"	14'-8"	12'-9"	11'-5"	10'-0"	8'-5"	10'-5"	9'-1"	7'-8"	9'-8"	8'-5"	7'-1"	9'-1"	7'-11"	6'-8"	8'-7"
	24		16'-1"	12'-9"	11'-2"	10'-0"	8'-9"	7'-4"	9'-1"	7'-11"	6'-8"	8'-5"	7'-4"	6'-2"	7'-11"	6'-11"	5'-10"	7'-5"
250S137-54	12	50	20'-3"	16'-1"	14'-1"	12'-7"	11'-0"	9'-3"	11'-5"	10'-0"	8'-5"	10'-7"	9'-3"	7'-10"	10'-0"	8'-9"	7'-4"	9'-6"
	16		18'-5"	14'-8"	12'-9"	11'-5"	10'-0"	8'-5"	10'-5"	9'-1"	7'-8"	9'-8"	8'-5"	7'-1"	9'-1"	7'-11"	6'-8"	8'-7"
	24		16'-1"	12'-9"	11'-2"	10'-0"	8'-9"	7'-4"	9'-1"	7'-11"	6'-8"	8'-5"	7'-4"	6'-2"	7'-11"	6'-11"	5'-10"	7'-6"
250S137-68	12	50	19'-8"	15'-7"	13'-8"	12'-2"	10'-8"	9'-0"	11'-1"	9'-8"	8'-2"	10'-3"	9'-0"	7'-7"	9'-8"	8'-5"	7'-1"	9'-2"
	16		17'-2"	13'-8"	11'-11"	10'-8"	9'-4"	7'-10"	9'-8"	8'-5"	7'-1"	9'-0"	7'-10"	6'-7"	8'-5"	7'-5"	6'-3"	8'-0"
	24		18'-4"	14'-7"	12'-9"	11'-4"	9'-11"	8'-5"	10'-4"	9'-0"	7'-7"	9'-7"	8'-5"	7'-1"	8'-10"	7'-11"	6'-8"	8'-3"
250S162-33	12	33	16'-8"	13'-3"	11'-7"	10'-4"	9'-0"	7'-7"	9'-5"	8'-2"	6'-11"	8'-5"	7'-7"	6'-5"	7'-8"	7'-2"	6'-0"	7'-1"
	16		14'-7"	11'-7"	10'-1"	8'-10"	7'-11"	6'-8"	7'-8"	7'-2"	6'-0"	6'-10"	6'-8"	5'-7"	6'-3"	5'-3"	5'-10"	5'-10"
	24		19'-11"	15'-10"	13'-10"	12'-4"	10'-10"	9'-1"	11'-3"	9'-10"	8'-3"	10'-5"	9'-1"	7'-8"	9'-10"	8'-7"	7'-3"	9'-4"
250S162-43	12	33	18'-1"	14'-5"	12'-7"	11'-3"	9'-10"	8'-3"	10'-2"	8'-11"	7'-6"	9'-6"	8'-3"	7'-0"	8'-11"	7'-9"	6'-7"	8'-6"
	16		15'-10"	12'-7"	11'-0"	9'-10"	8'-7"	7'-3"	8'-11"	7'-9"	8'-3"	7'-7"	6'-3"	6'-1"	7'-7"	6'-10"	5'-9"	7'-0"
	24		21'-4"	16'-11"	14'-9"	13'-3"	11'-7"	9'-5"	12'-0"	10'-6"	8'-10"	11'-2"	9'-9"	8'-3"	10'-6"	9'-2"	7'-9"	10'-1"
250S162-54	12	33	19'-5"	15'-5"	13'-5"	12'-0"	10'-6"	8'-10"	10'-11"	9'-6"	10'-2"	8'-10"	7'-6"	9'-6"	8'-4"	7'-0"	9'-0"	9'-0"
	16		16'-11"	13'-5"	11'-9"	10'-6"	9'-2"	7'-9"	9'-6"	8'-4"	7'-0"	8'-10"	7'-9"	6'-6"	8'-4"	7'-3"	6'-2"	7'-11"
	24		22'-9"	18'-1"	15'-10"	14'-1"	12'-4"	10'-5"	12'-10"	11'-2"	9'-5"	11'-11"	10'-5"	8'-9"	11'-2"	9'-9"	8'-3"	10'-8"
250S162-54	12	50	20'-8"	16'-5"	14'-4"	12'-10"	11'-2"	9'-5"	11'-8"	10'-2"	8'-7"	10'-10"	9'-5"	8'-0"	10'-2"	8'-11"	7'-6"	9'-8"
	16		18'-1"	14'-4"	12'-6"	11'-2"	9'-9"	8'-3"	10'-2"	8'-11"	7'-6"	9'-5"	8'-3"	7'-0"	8'-11"	7'-9"	6'-7"	8'-5"
	24		23'-0"	18'-10"	16'-5"	14'-8"	12'-10"	10'-10"	13'-2"	11'-8"	9'-10"	11'-10"	10'-10"	9'-2"	10'-9"	10'-2"	8'-7"	10'-0"
350S162-33	12	33	21'-7"	17'-1"	14'-11"	13'-2"	11'-8"	9'-10"	11'-5"	10'-7"	8'-11"	10'-3"	9'-10"	8'-4"	9'-4"	9'-3"	7'-10"	8'-8"
	16		18'-8"	14'-11"	13'-1"	10'-9"	10'-2"	8'-7"	9'-4"	9'-3"	7'-10"	8'-4"	7'-7"	7'-7"	7'-7"	6'-10"	7'-1"	8'-8"
	24		25'-10"	20'-6"	17'-11"	16'-0"	14'-0"	11'-9"	14'-6"	12'-8"	10'-8"	13'-6"	11'-9"	9'-11"	12'-8"	11'-1"	9'-4"	11'-8"
350S162-43	12	33	23'-5"	18'-7"	16'-3"	14'-6"	12'-8"	10'-8"	13'-2"	11'-6"	9'-9"	12'-0"	10'-8"	9'-0"	10'-11"	10'-1"	8'-6"	10'-2"
	16		20'-6"	16'-3"	14'-2"	12'-8"	11'-1"	9'-4"	10'-11"	10'-1"	8'-6"	9'-9"	9'-4"	7'-11"	8'-11"	8'-10"	7'-5"	8'-3"
	24		27'-8"	21'-11"	19'-2"	17'-2"	15'-0"	12'-7"	15'-7"	13'-7"	11'-6"	14'-5"	12'-7"	10'-8"	13'-7"	11'-11"	10'-0"	12'-11"
350S162-54	12	33	25'-1"	19'-11"	17'-5"	15'-7"	13'-7"	11'-6"	14'-2"	12'-4"	10'-5"	13'-1"	11'-6"	9'-8"	12'-4"	10'-9"	9'-1"	11'-9"
	16		21'-11"	17'-5"	15'-2"	13'-7"	11'-11"	10'-0"	12'-4"	10'-9"	9'-1"	11'-6"	10'-0"	8'-5"	10'-9"	9'-5"	7'-11"	10'-3"
	24		29'-7"	23'-6"	20'-6"	18'-4"	16'-0"	13'-6"	16'-8"	14'-7"	12'-3"	15'-5"	13'-6"	11'-5"	14'-7"	12'-8"	10'-9"	13'-10"
350S162-68	12	50	26'-10"	21'-4"	18'-7"	16'-8"	14'-7"	12'-3"	15'-1"	13'-3"	11'-2"	14'-0"	12'-3"	10'-4"	13'-3"	11'-7"	9'-9"	12'-7"
	16		23'-6"	18'-7"	16'-3"	14'-7"	12'-8"	10'-9"	13'-3"	11'-7"	9'-9"	12'-3"	10'-9"	9'-0"	11'-7"	11'-11"	8'-6"	11'-0"
	24		32'-7"	25'-11"	22'-7"	20'-3"	17'-8"	14'-11"	18'-4"	16'-0"	13'-6"	17'-1"	14'-11"	12'-7"	16'-0"	14'-0"	11'-10"	15'-3"
350S162-97	12	50	29'-8"	23'-6"	20'-7"	18'-4"	16'-0"	13'-6"	16'-8"	14'-7"	12'-4"	15'-6"	13'-6"	11'-5"	14'-7"	12'-9"	10'-9"	13'-10"
	16		25'-11"	20'-7"	17'-11"	16'-0"	14'-0"	11'-10"	14'-7"	12'-9"	10'-9"	13'-6"	11'-10"	10'-0"	12'-9"	11'-1"	9'-5"	12'-1"
	24		27'-3"	21'-8"	18'-11"	16'-11"	14'-9"	12'-5"	15'-4"	13'-5"	11'-4"	14'-3"	12'-5"	10'-6"	13'-5"	11'-9"	9'-11"	12'-6"
350S200-43	12	33	24'-9"	19'-8"	17'-2"	15'-4"	13'-5"	11'-4"	13'-11"	12'-2"	10'-3"	12'-10"	11'-4"	9'-6"	11'-9"	10'-8"	9'-0"	10'-10"
	16		21'-8"	17'-2"	15'-0"	13'-5"	11'-9"	9'-11"	11'-9"	10'-8"	9'-0"	10'-6"	9'-11"	8'-4"	9'-7"	9'-4"	7'-10"	8'-10"
	24		21'-8"	17'-2"	15'-0"	13'-5"	11'-9"	9'-11"	11'-9"	10'-8"	9'-0"	10'-6"	9'-11"	8'-4"	9'-7"	9'-4"	7'-10"	8'-10"

## Curtain Wall – Limiting Wall Heights (Continued)

Stud Member	Spacing	Fy (ksi)	5 psf			15 psf			20 psf			25 psf			30 psf			35 psf			40 psf			
			L/120	L/240	L/360	L/120	L/240	L/360	L/120	L/240	L/360	L/120	L/240	L/360	L/120	L/240	L/360	L/120	L/240	L/360	L/120	L/240	L/360	
350S200-54	12	33	29'-3"	23'-2"	20'-3"	18'-1"	15'-10"	13'-4"	16'-5"	14'-4"	12'-1"	15'-3"	13'-4"	11'-3"	14'-4"	12'-7"	10'-7"	13'-8"	11'-11"	10'-1"	13'-1"	11'-5"	9'-7"	
	16		26'-6"	21'-1"	18'-5"	16'-5"	14'-4"	12'-1"	14'-11"	13'-1"	11'-0"	13'-10"	12'-1"	10'-3"	13'-1"	11'-5"	9'-7"	12'-5"	10'-10"	9'-2"	11'-10"	10'-4"	8'-9"	
	24		23'-2"	18'-5"	16'-1"	14'-4"	12'-7"	10'-7"	13'-1"	11'-5"	9'-7"	12'-1"	10'-7"	8'-11"	11'-4"	10'-0"	8'-5"	10'-6"	9'-6"	8'-0"	9'-10"	9'-1"	7'-8"	
350S200-54	12	50	29'-3"	23'-2"	20'-3"	18'-1"	15'-10"	13'-4"	16'-5"	14'-4"	12'-1"	15'-3"	13'-4"	11'-3"	14'-4"	12'-7"	10'-7"	13'-8"	11'-11"	10'-1"	13'-1"	11'-5"	9'-7"	
	16		26'-6"	21'-1"	18'-5"	16'-5"	14'-4"	12'-1"	14'-11"	13'-1"	11'-0"	13'-10"	12'-1"	10'-3"	13'-1"	11'-5"	9'-7"	12'-5"	10'-10"	9'-2"	11'-10"	10'-4"	8'-9"	
	24		23'-2"	18'-5"	16'-1"	14'-4"	12'-7"	10'-7"	13'-1"	11'-5"	9'-7"	12'-1"	10'-7"	8'-11"	11'-5"	10'-0"	8'-5"	10'-10"	9'-6"	8'-0"	10'-4"	9'-1"	7'-8"	
350S200-68	12	50	31'-3"	24'-10"	21'-8"	19'-5"	16'-11"	14'-3"	17'-7"	15'-5"	13'-0"	16'-4"	14'-3"	12'-1"	15'-5"	11'-4"	13'-5"	11'-4"	14'-7"	12'-9"	10'-9"	14'-0"	12'-3"	10'-4"
	16		28'-5"	22'-7"	19'-8"	17'-7"	15'-5"	13'-0"	16'-0"	14'-0"	11'-10"	14'-10"	13'-0"	10'-11"	14'-0"	12'-3"	10'-4"	13'-3"	11'-7"	9'-9"	12'-8"	11'-1"	9'-4"	
	24		24'-10"	19'-8"	17'-3"	15'-5"	13'-5"	11'-4"	14'-0"	12'-3"	10'-4"	13'-0"	11'-4"	9'-7"	12'-3"	10'-8"	9'-0"	11'-7"	10'-2"	8'-7"	11'-1"	9'-8"	8'-2"	
350S200-97	12	50	34'-7"	27'-5"	24'-0"	21'-5"	18'-9"	15'-10"	19'-6"	17'-0"	14'-4"	18'-1"	15'-10"	13'-4"	17'-0"	14'-10"	12'-6"	16'-2"	14'-1"	11'-11"	15'-6"	13'-6"	11'-5"	
	16		31'-5"	24'-11"	21'-9"	19'-6"	17'-0"	14'-4"	17'-8"	15'-6"	13'-0"	16'-5"	14'-4"	12'-1"	15'-6"	13'-6"	11'-5"	14'-8"	12'-10"	10'-10"	14'-1"	12'-3"	10'-4"	
	24		27'-5"	21'-9"	19'-0"	17'-0"	14'-10"	12'-6"	15'-6"	13'-6"	11'-5"	14'-4"	12'-6"	10'-7"	13'-6"	11'-10"	9'-11"	12'-10"	11'-2"	9'-5"	12'-3"	10'-9"	9'-0"	
362S137-33	12	33	23'-3"	18'-5"	16'-1"	14'-5"	12'-7"	10'-7"	12'-7"	11'-5"	9'-8"	11'-3"	10'-7"	8'-11"	10'-3"	8'-5"	9'-6"	9'-6"	8'-0"	8'-11"	8'-11"	7'-8"		
	16		21'-1"	16'-9"	14'-8"	12'-7"	11'-5"	9'-8"	10'-11"	10'-5"	8'-9"	9'-9"	9'-8"	8'-2"	8'-11"	8'-11"	7'-8"	8'-3"	7'-3"	7'-8"	7'-8"	6'-11"		
	24		17'-9"	14'-8"	12'-10"	10'-3"	10'-0"	8'-5"	8'-11"	8'-11"	7'-8"	8'-4"	7'-11"	7'-3"	7'-3"	6'-8"	6'-8"	6'-9"	6'-9"	6'-4"	6'-3"	6'-3"	6'-1"	
362S137-43	12	33	25'-3"	20'-1"	17'-6"	15'-8"	13'-8"	11'-7"	14'-3"	12'-5"	10'-6"	13'-2"	11'-7"	9'-9"	12'-0"	10'-10"	9'-2"	11'-1"	10'-4"	8'-8"	10'-5"	9'-10"	8'-4"	
	16		23'-0"	18'-3"	15'-11"	14'-3"	12'-5"	10'-6"	12'-9"	11'-4"	9'-6"	11'-5"	10'-6"	8'-10"	10'-5"	9'-10"	8'-4"	9'-7"	9'-5"	7'-11"	9'-0"	9'-0"	7'-7"	
	24		20'-1"	15'-11"	13'-11"	12'-0"	10'-10"	9'-2"	10'-5"	9'-10"	8'-4"	9'-4"	7'-9"	6'-8"	8'-6"	7'-3"	7'-10"	7'-10"	6'-11"	7'-4"	7'-4"	6'-7"		
362S137-54	12	33	27'-1"	21'-6"	18'-9"	16'-9"	14'-8"	12'-4"	15'-3"	13'-4"	11'-3"	14'-2"	12'-4"	10'-5"	13'-4"	11'-8"	9'-10"	12'-8"	11'-1"	9'-4"	12'-1"	10'-7"	8'-11"	
	16		24'-7"	19'-6"	17'-1"	15'-3"	13'-4"	11'-3"	13'-10"	12'-1"	10'-2"	12'-10"	11'-3"	9'-6"	12'-1"	10'-7"	8'-11"	11'-3"	10'-0"	8'-6"	10'-6"	9'-7"	8'-1"	
	24		21'-6"	17'-1"	14'-11"	13'-4"	11'-8"	9'-10"	12'-1"	10'-7"	8'-11"	11'-3"	9'-10"	8'-3"	9'-3"	7'-9"	9'-2"	8'-9"	7'-5"	8'-7"	8'-7"	8'-5"	7'-1"	
362S137-54	12	50	27'-1"	21'-6"	18'-9"	16'-9"	14'-8"	12'-4"	15'-3"	13'-4"	11'-3"	14'-2"	12'-4"	10'-5"	13'-4"	11'-8"	9'-10"	12'-8"	11'-1"	9'-4"	12'-1"	10'-7"	8'-11"	
	16		24'-7"	19'-6"	17'-1"	15'-3"	13'-4"	11'-3"	13'-10"	12'-1"	10'-2"	12'-10"	11'-3"	9'-6"	12'-1"	10'-7"	8'-11"	11'-6"	10'-0"	8'-6"	11'-0"	9'-7"	8'-1"	
	24		21'-6"	17'-1"	14'-11"	13'-4"	11'-8"	9'-10"	12'-1"	10'-7"	8'-11"	11'-3"	9'-10"	8'-3"	9'-3"	7'-9"	9'-2"	8'-9"	7'-5"	8'-7"	8'-7"	8'-5"	7'-1"	
362S137-68	12	50	28'-11"	23'-0"	20'-1"	17'-11"	15'-8"	13'-3"	16'-3"	14'-3"	12'-0"	15'-1"	13'-3"	11'-2"	14'-3"	12'-5"	10'-6"	13'-6"	11'-10"	10'-0"	12'-11"	11'-4"	9'-6"	
	16		26'-3"	20'-10"	18'-3"	16'-3"	14'-3"	12'-0"	14'-10"	12'-11"	10'-11"	13'-9"	12'-0"	10'-1"	12'-11"	11'-4"	9'-6"	12'-3"	10'-9"	9'-1"	11'-9"	10'-3"	8'-8"	
	24		23'-0"	18'-3"	15'-11"	14'-3"	12'-5"	10'-6"	12'-11"	11'-4"	9'-6"	12'-0"	10'-6"	8'-10"	11'-4"	9'-10"	8'-4"	10'-9"	9'-4"	7'-11"	10'-3"	9'-0"	7'-7"	
362S162-33	12	33	24'-4"	19'-4"	16'-11"	15'-1"	13'-2"	11'-1"	13'-6"	12'-0"	10'-1"	12'-1"	11'-1"	9'-5"	11'-0"	10'-6"	8'-10"	10'-2"	9'-11"	8'-5"	9'-6"	9'-6"	8'-0"	
	16		22'-2"	17'-7"	15'-4"	13'-6"	12'-0"	10'-1"	11'-8"	10'-11"	9'-2"	10'-5"	10'-1"	8'-6"	9'-6"	8'-0"	9'-6"	8'-10"	8'-10"	7'-7"	8'-3"	8'-3"	6'-1"	
	24		19'-0"	15'-4"	13'-5"	11'-0"	10'-6"	8'-10"	9'-6"	9'-6"	8'-0"	8'-6"	8'-6"	7'-5"	7'-9"	7'-9"	7'-0"	7'-2"	7'-2"	6'-8"	6'-9"	6'-9"	6'-4"	
362S162-43	12	33	26'-6"	21'-0"	18'-5"	16'-5"	14'-4"	12'-1"	14'-11"	13'-0"	11'-0"	13'-10"	12'-1"	10'-2"	12'-11"	11'-5"	9'-7"	11'-11"	10'-10"	9'-2"	11'-2"	10'-4"	8'-9"	
	16		24'-1"	19'-1"	16'-8"	14'-11"	13'-0"	11'-0"	13'-7"	11'-10"	10'-0"	12'-3"	11'-0"	9'-3"	11'-2"	10'-4"	8'-9"	10'-4"	9'-10"	8'-3"	9'-8"	9'-5"	7'-11"	
	24		21'-0"	16'-8"	14'-7"	12'-11"	11'-5"	9'-7"	11'-2"	10'-4"	8'-9"	10'-0"	9'-7"	8'-1"	9'-2"	9'-0"	7'-7"	8'-5"	8'-5"	7'-3"	7'-11"	7'-11"	6'-11"	
350S162-54	12	33	27'-8"	21'-11"	19'-2"	17'-2"	15'-0"	12'-7"	15'-7"	13'-7"	11'-6"	14'-5"	12'-7"	10'-8"	13'-7"	11'-11"	10'-0"	12'-11"	11'-3"	9'-6"	12'-4"	10'-9"	9'-1"	
	16		25'-1"	19'-11"	17'-5"	15'-7"	13'-7"	11'-6"	14'-2"	12'-4"	10'-5"	13'-1"	11'-6"	9'-8"	12'-4"	10'-9"	9'-1"	11'-9"	10'-3"	8'-8"	11'-2"	9'-10"	8'-3"	
	24		21'-11"	17'-5"	15'-2"	13'-7"	11'-11"	10'-0"	12'-4"	10'-9"	9'-1"	11'-6"	10'-0"	8'-5"	10'-7"	9'-5"	7'-11"	9'-9"	8'-11"	7'-7"	9'-2"	8'-7"	7'-3"	
350S162-54	12	50	27'-8"	21'-11"	19'-2"	17'-2"	15'-0"	12'-7"	15'-7"	13'-7"	11'-6"	14'-5"	12'-7"	10'-8"	13'-7"	11'-11"	10'-0"	12'-11"	11'-3"	9'-6"	12'-4"	10'-9"	9'-1"	
	16		25'-1"	19'-11"	17'-5"	15'-7"	13'-7"	11'-6"	14'-2"	12'-4"	10'-5"	13'-1"	11'-6"	9'-8"	12'-4"	10'-9"	9'-1"	11'-9"	10'-3"	8'-8"	11'-2"	9'-10"	8'-3"	
	24		21'-11"	17'-5"	15'-2"	13'-7"	11'-11"	10'-0"	12'-4"	10'-9"	9'-1"	11'-6"	10'-0"	8'-5"	10'-7"	9'-5"	7'-11"	9'-9"	8'-11"	7'-7"	9'-2"	8'-7"	7'-3"	
350S162-68	12	50	27'-8"	21'-11"	19'-2"	17'-2"	15'-0"	12'-7"	15'-7"	13'-7"	11'-6"	14'-5"	12'-7"	10'-8"	13'-7"	11'-11"	10'-0"	12'-11"	11'-3"	9'-6"	12'-4"	10'-9"	9'-1"	
	16		25'-1"	19'-11"	17'-5"	15'-7"	13'-7"	11'-6"	14'-2"	12'-4"	10'-5"	13'-1"	11'-6"	9'-8"	12'-4"	10'-9"	9'-1"	11'-9"	10'-3"	8'-8"	11'-2"	9'-10"	8'-3"	
	24		21'-11"	17'-5"	15'-2"	13'-7"	11'-11"	10'-0"	12'-4"	10'-9"	9'-1"	11'-6"	10'-0"	8'-5"	10'-7"	9'-5"	7'-11"	9'-9"	8'-11"	7'-7"	9'-2"	8'-7"	7'-3"	
350S162-88	12	50	29'-7"	23'-6"	20'-6"	18'-4"	16'-0"	13'-6"	16'-8"	14'-7"	12'-3"	15'-5"	13'-6"	11'-5"	14'-7"	12'-8"	10'-9"	13'-10"	12'-1"	10'-2"	13'-3"	11'-7"	9'-9"	
	16		26'-10"	21'-4"	18'-7"	16'-8"	14'-7"	12'-3"	15'-1"	13'-3"	11'-2"	14'-0"	12'-3"	10'-4"	13'-3"	11'-7"	9'-9"	12'-7"	11'-0"	9'-3"	12'-0"	10'-6"	8'-10"	
	24		23'-6"	18'-7"	16'-3"	14'-7"	12'-8"	10'-9"	13'-3"	11'-7"	9'-9"	12'-3"	10'-9"	9'-0"	11'-7"	10'-1"	8'-6"	11'-0"	9'-7"	8'-1"	10'-6"	9'-2"	7'-9"	
350S162-97	12	50	32'-7"	25'-11"	22'-7"	20'-3"	17'-8"	14'-11"	18'-4"	16'-0"	13'-6"	17'-1"	14'-11"	12'-7"	16'-0"	14'-0"	11'-10"	15'-3"	13'-4"	11'-3"	14'-7"	12'-9"	10'-9"	
	16		29'-8"	23'-6"	20'-7"	18'-4"	16'-0"	13'-6"	16'-8"	14'-7"	12'-4"	15'-6"	13'-6"	11'-5"	14'-7"	12'-9"	10'-9"	13'-10"	12'-1"	10'-2"	13'-3"	11'-7"	9'-9"	
	24		25'-11"	20'-7"	17'-11"	16'-0"	14'-0"	11'-10"	14'-7"	12'-9"	10'-9"	13'-6"	11'-10"	10'-0"	12'-9"	11'-1"	9'-5"	12'-1"	10'-7"	8'-11"	11'-7"	10'-1"	8'-6"	
350S200-43	12	33	27'-3"	21'-8"	18'-11"	16'-11"	14'-9"	12'-5"	15'-4"	13'-5"	11'-4"	14'-3"	12'-5"	10'-6"	13'-5"	11'-9"	9'-11"	12'-6"	11'-1"	9'-5"	11'-9"	10'-8"	9'-0"	
	16		24'-9"	19'-8"	17'-2"	15'-4"	13'-5"	11'-4"	13'-11"	12'-2"	10'-3"	12'-10"	11'-4"	9'-6"	11'-9"	10'-8"	9'-0"	10'-10"	10'-1"	8'-6"	10'-2"	9'-8"	8'-2"	
	24		21'-8"	17'-2"	15'-0"	13'-5"	11'-9"	9'-11"	11'-9"	10'-8"	9'-0"	10'-6"	9'-11"	8'-4"	9'-7"	8'-10"	7'-10"	8'-10"	7'-5"	8'-4"	8'-4"	7'-1"		
350S200-54	12	33																						

## Curtain Wall – Limiting Wall Heights (Continued)

Stud Member	Spacing	Fy (ksi)	5 psf			15 psf			20 psf			25 psf			30 psf			35 psf			40 psf		
			L/120	L/240	L/360	L/120	L/240	L/360	L/120	L/240	L/360	L/120	L/240	L/360	L/120	L/240	L/360	L/120	L/240	L/360	L/120	L/240	L/360
3625137-33	12	33	23'-3"	18'-5"	16'-1"	14'-5"	12'-7"	10'-7"	12'-7"	11'-5"	9'-8"	11'-3"	10'-7"	8'-11"	10'-3"	10'-0"	8'-5"	9'-6"	9'-6"	8'-0"	8'-11"	8'-11"	7'-8"
	16		21'-1"	16'-9"	14'-8"	12'-7"	11'-5"	9'-8"	10'-11"	10'-5"	8'-9"	9'-9"	9'-8"	8'-2"	8'-11"	8'-11"	7'-8"	8'-3"	8'-3"	6'-9"	7'-3"	7'-8"	6'-11"
	24		17'-9"	14'-8"	12'-10"	10'-3"	10'-0"	8'-5"	8'-11"	8'-11"	7'-8"	7'-11"	7'-11"	7'-1"	7'-3"	7'-3"	6'-8"	6'-9"	6'-9"	6'-4"	6'-3"	6'-3"	6'-1"
3625137-43	12	33	25'-3"	20'-1"	17'-6"	15'-8"	13'-8"	11'-7"	14'-3"	12'-5"	10'-6"	13'-2"	11'-7"	9'-9"	12'-0"	10'-10"	9'-2"	11'-1"	10'-4"	8'-8"	10'-5"	9'-10"	8'-8"
	16		23'-0"	18'-3"	15'-11"	14'-3"	12'-5"	10'-6"	12'-9"	11'-4"	9'-6"	11'-5"	10'-6"	8'-10"	10'-5"	9'-10"	8'-4"	9'-7"	9'-5"	7'-11"	9'-0"	9'-0"	7'-7"
	24		20'-1"	15'-11"	13'-11"	12'-0"	10'-10"	9'-2"	10'-5"	9'-10"	8'-4"	9'-4"	9'-2"	7'-9"	8'-6"	8'-6"	7'-3"	7'-10"	7'-10"	6'-11"	7'-4"	7'-4"	6'-7"
3625137-54	12	33	27'-1"	21'-6"	18'-9"	16'-9"	14'-8"	12'-4"	15'-3"	13'-4"	11'-3"	14'-2"	12'-4"	10'-5"	13'-4"	11'-8"	9'-10"	12'-8"	11'-1"	9'-4"	12'-1"	10'-7"	8'-11"
	16		24'-7"	19'-6"	17'-1"	15'-3"	13'-4"	11'-3"	13'-10"	12'-1"	10'-2"	12'-10"	11'-3"	9'-6"	12'-1"	10'-7"	8'-11"	11'-3"	10'-0"	8'-6"	10'-6"	9'-7"	8'-1"
	24		21'-6"	17'-1"	14'-11"	13'-4"	11'-8"	9'-10"	12'-1"	10'-7"	8'-11"	10'-10"	9'-10"	8'-3"	9'-11"	9'-3"	7'-9"	9'-2"	8'-9"	7'-5"	8'-7"	8'-5"	7'-1"
3625137-54	12	50	27'-1"	21'-6"	18'-9"	16'-9"	14'-8"	12'-4"	15'-3"	13'-4"	11'-3"	14'-2"	12'-4"	10'-5"	13'-4"	11'-8"	9'-10"	12'-8"	11'-1"	9'-4"	12'-1"	10'-7"	8'-11"
	16		24'-7"	19'-6"	17'-1"	15'-3"	13'-4"	11'-3"	13'-10"	12'-1"	10'-2"	12'-10"	11'-3"	9'-6"	12'-1"	10'-7"	8'-11"	11'-6"	10'-0"	8'-6"	11'-0"	9'-7"	8'-1"
	24		21'-6"	17'-1"	14'-11"	13'-4"	11'-8"	9'-10"	12'-1"	10'-7"	8'-11"	11'-3"	9'-10"	8'-3"	10'-7"	9'-3"	7'-9"	10'-0"	8'-9"	7'-5"	9'-7"	8'-5"	7'-1"
3625137-68	12	50	28'-11"	23'-0"	20'-1"	17'-11"	15'-8"	13'-3"	16'-3"	14'-3"	12'-0"	15'-1"	13'-3"	11'-2"	14'-3"	12'-5"	10'-6"	13'-6"	11'-10"	10'-0"	12'-11"	11'-4"	9'-6"
	16		26'-3"	20'-10"	18'-3"	16'-3"	14'-3"	12'-0"	14'-10"	12'-11"	10'-11"	13'-9"	12'-0"	10'-1"	12'-11"	11'-4"	9'-6"	12'-3"	10'-9"	9'-1"	11'-9"	10'-3"	8'-8"
	24		23'-0"	18'-3"	15'-11"	14'-3"	12'-5"	10'-6"	12'-11"	11'-4"	9'-6"	12'-0"	10'-6"	8'-10"	11'-4"	9'-10"	8'-4"	10'-9"	9'-4"	7'-11"	10'-3"	9'-0"	7'-7"
3625162-33	12	33	24'-4"	19'-4"	16'-11"	15'-1"	13'-2"	11'-1"	13'-6"	12'-0"	10'-1"	12'-1"	11'-1"	9'-5"	11'-0"	10'-6"	8'-10"	10'-2"	9'-11"	8'-5"	9'-6"	9'-6"	8'-0"
	16		22'-2"	17'-7"	15'-4"	13'-6"	12'-0"	10'-1"	11'-8"	10'-11"	9'-2"	10'-5"	10'-1"	8'-6"	9'-6"	9'-6"	8'-0"	8'-10"	8'-10"	7'-7"	8'-3"	8'-3"	7'-3"
	24		19'-0"	15'-4"	13'-5"	11'-0"	10'-6"	8'-10"	9'-6"	9'-6"	8'-0"	8'-6"	8'-6"	7'-5"	7'-9"	7'-9"	7'-0"	7'-2"	7'-2"	6'-8"	6'-9"	6'-9"	6'-4"
3625162-43	12	33	26'-6"	21'-0"	18'-5"	16'-5"	14'-4"	12'-1"	14'-11"	13'-0"	11'-0"	13'-10"	12'-1"	10'-2"	12'-11"	11'-5"	9'-7"	11'-11"	10'-10"	9'-2"	11'-2"	10'-4"	8'-9"
	16		24'-1"	19'-1"	16'-8"	14'-11"	13'-0"	11'-0"	13'-7"	11'-10"	10'-0"	12'-3"	11'-0"	9'-3"	11'-2"	10'-4"	8'-9"	10'-4"	9'-10"	8'-3"	9'-8"	9'-5"	7'-11"
	24		21'-0"	16'-8"	14'-7"	12'-11"	11'-5"	9'-7"	11'-2"	10'-4"	8'-9"	10'-0"	9'-7"	8'-1"	9'-2"	9'-0"	7'-7"	8'-5"	8'-5"	7'-3"	7'-11"	7'-11"	6'-11"
3625162-54	12	33	28'-5"	22'-6"	19'-8"	17'-7"	15'-4"	13'-0"	16'-0"	14'-0"	11'-9"	14'-10"	13'-0"	10'-11"	14'-0"	12'-2"	10'-4"	13'-3"	11'-7"	9'-9"	12'-8"	11'-1"	9'-4"
	16		25'-10"	20'-6"	17'-11"	16'-0"	14'-0"	11'-9"	14'-6"	12'-8"	10'-8"	13'-6"	11'-9"	9'-11"	12'-8"	11'-1"	9'-4"	12'-1"	10'-6"	8'-11"	11'-4"	10'-1"	8'-6"
	24		22'-6"	17'-11"	15'-8"	14'-0"	12'-2"	10'-4"	12'-8"	11'-1"	9'-4"	11'-9"	10'-4"	8'-8"	11'-1"	9'-8"	8'-2"	9'-11"	9'-2"	7'-9"	9'-3"	8'-10"	7'-5"
3625162-54	12	50	28'-5"	22'-6"	19'-8"	17'-7"	15'-4"	13'-0"	16'-0"	14'-0"	11'-9"	14'-10"	13'-0"	10'-11"	14'-0"	12'-2"	10'-4"	13'-3"	11'-7"	9'-9"	12'-8"	11'-1"	9'-4"
	16		25'-10"	20'-6"	17'-11"	16'-0"	14'-0"	11'-9"	14'-6"	12'-8"	10'-8"	13'-6"	11'-9"	9'-11"	12'-8"	11'-1"	9'-4"	12'-1"	10'-6"	8'-11"	11'-6"	10'-1"	8'-6"
	24		22'-6"	17'-11"	15'-8"	14'-0"	12'-2"	10'-4"	12'-8"	11'-1"	9'-4"	11'-9"	10'-4"	8'-8"	11'-1"	9'-8"	8'-2"	10'-6"	9'-2"	7'-9"	10'-1"	8'-10"	7'-5"
3625162-68	12	50	30'-5"	24'-1"	21'-1"	18'-10"	16'-5"	13'-10"	17'-1"	14'-11"	12'-7"	15'-11"	13'-10"	11'-8"	14'-11"	13'-1"	11'-0"	14'-2"	12'-5"	10'-6"	13'-7"	11'-10"	10'-0"
	16		27'-7"	21'-11"	19'-2"	17'-1"	14'-11"	12'-7"	15'-7"	13'-7"	11'-5"	14'-5"	12'-7"	10'-8"	13'-7"	11'-10"	10'-0"	12'-11"	11'-3"	9'-6"	12'-4"	10'-9"	9'-1"
	24		24'-1"	19'-2"	16'-9"	14'-11"	13'-1"	11'-0"	13'-7"	11'-10"	10'-0"	12'-7"	11'-0"	9'-3"	11'-10"	10'-4"	8'-9"	11'-3"	9'-10"	8'-4"	10'-9"	9'-5"	7'-11"
3625162-97	12	50	33'-6"	26'-7"	23'-3"	20'-9"	18'-2"	15'-4"	18'-11"	16'-6"	13'-11"	17'-6"	15'-4"	12'-11"	16'-6"	14'-5"	12'-2"	15'-8"	13'-8"	11'-7"	15'-0"	13'-1"	11'-0"
	16		30'-5"	24'-2"	21'-1"	18'-11"	16'-6"	13'-11"	17'-2"	15'-0"	12'-8"	15'-11"	13'-11"	11'-9"	15'-0"	13'-1"	11'-0"	14'-3"	12'-5"	10'-6"	13'-7"	11'-11"	10'-0"
	24		26'-7"	21'-1"	18'-5"	16'-6"	14'-5"	12'-2"	15'-0"	13'-1"	11'-0"	13'-11"	12'-2"	10'-3"	13'-1"	11'-5"	9'-8"	12'-5"	10'-10"	9'-2"	11'-11"	10'-5"	8'-9"
3625200-33	12	33	25'-8"	20'-5"	17'-10"	15'-11"	13'-11"	11'-9"	14'-1"	12'-8"	10'-8"	12'-7"	11'-9"	9'-11"	11'-6"	11'-0"	9'-4"	10'-8"	10'-6"	8'-10"	10'-0"	10'-0"	8'-6"
	16		23'-4"	18'-6"	16'-2"	14'-1"	12'-8"	10'-8"	12'-2"	11'-6"	9'-8"	10'-11"	10'-8"	9'-0"	10'-0"	8'-6"	9'-3"	9'-3"	8'-0"	8'-8"	8'-8"	7'-8"	
	24		19'-11"	16'-2"	14'-2"	11'-6"	11'-0"	9'-4"	10'-0"	10'-0"	8'-6"	8'-11"	8'-11"	7'-10"	8'-2"	8'-2"	7'-5"	7'-6"	7'-6"	7'-1"	7'-1"	6'-9"	6'-9"
3625200-43	12	33	28'-0"	22'-3"	19'-5"	17'-4"	15'-2"	12'-9"	15'-9"	13'-9"	11'-7"	14'-8"	12'-9"	10'-9"	13'-9"	12'-0"	10'-2"	12'-10"	11'-5"	9'-8"	12'-0"	10'-11"	9'-3"
	16		25'-5"	20'-2"	17'-8"	15'-9"	13'-9"	11'-7"	14'-4"	12'-6"	10'-7"	13'-2"	11'-7"	9'-10"	12'-0"	10'-11"	9'-3"	11'-1"	10'-5"	8'-9"	10'-5"	9'-11"	8'-4"
	24		22'-3"	17'-8"	15'-5"	13'-9"	12'-0"	10'-2"	12'-0"	10'-11"	9'-3"	10'-9"	10'-2"	8'-7"	9'-9"	9'-7"	8'-1"	9'-1"	9'-1"	7'-8"	8'-6"	8'-6"	7'-4"
3625200-54	12	33	30'-0"	23'-10"	20'-10"	18'-7"	16'-3"	13'-8"	16'-11"	14'-9"	12'-5"	15'-8"	13'-8"	11'-7"	14'-9"	12'-11"	10'-11"	14'-0"	12'-3"	10'-4"	13'-5"	11'-9"	9'-11"
	16		27'-3"	21'-8"	18'-11"	16'-11"	14'-9"	12'-5"	15'-4"	13'-5"	11'-4"	14'-3"	12'-5"	10'-6"	13'-5"	11'-9"	9'-11"	12'-9"	11'-2"	9'-5"	12'-2"	10'-8"	9'-0"
	24		23'-10"	18'-11"	16'-6"	14'-9"	12'-11"	10'-11"	13'-5"	11'-9"	9'-11"	12'-5"	10'-11"	9'-2"	11'-7"	10'-3"	8'-8"	10'-9"	9'-9"	8'-2"	10'-1"	9'-4"	7'-10"
3625200-54	12	50	30'-0"	23'-10"	20'-10"	18'-7"	16'-3"	13'-8"	16'-11"	14'-9"	12'-5"	15'-8"	13'-8"	11'-7"	14'-9"	12'-11"	10'-11"	14'-0"	12'-3"	10'-4"	13'-5"	11'-9"	9'-11"
	16		27'-3"	21'-8"	18'-11"	16'-11"	14'-9"	12'-5"	15'-4"	13'-5"	11'-4"	14'-3"	12'-5"	10'-6"	13'-5"	11'-9"	9'-11"	12'-9"	11'-2"	9'-5"	12'-2"	10'-8"	9'-0"
	24		23'-10"	18'-11"	16'-6"	14'-9"	12'-11"	10'-11"	13'-5"	11'-9"	9'-11"	12'-5"	10'-11"	9'-2"	11'-9"	10'-3"	8'-8"	11'-2"	9'-9"	8'-2"	10'-8"	9'-4"	7'-10"
3625200-68	12	50	32'-2"	25'-6"	22'-3"	19'-11"	17'-5"	14'-8"	18'-1"	15'-10"	13'-4"	16'-10"	14'-8"	12'-5"	15'-10"	13'-10"	11'-8"	15'-0"	13'-1"	11'-1"	14'-4"	12'-7"	10'-7"
	16		29'-2"	23'-2"	20'-3"	18'-1"	15'-10"	13'-4"	16'-5"	14'-4"	12'-1"	15'-3"	13'-4"	11'-3"	14'-4"	12'-7"	10'-7"	13'-8"	11'-11"	10'-1"	13'-1"	11'-5"	9'-7"
	24		25'-6"	20'-3"	17'-8"	15'-10"	13'-10"	11'-8"	14'-4"	12'-7"	10'-7"	13'-4"	11'-8"	9'-10"	12'-7"	11'-0"	9'-3"	11'-11"	10'-5"	8'-9"	11'-5"	10'-0"	8'-5"
3625200-97	12	50	35'-7"	28'-3"	24'-8"	22'-0"	19'-3"	16'-3"	20'-0"	17'-6"	14'-9"	18'-7"	16'-3"	13'-8"	17'-6"	15'-3"	12'-11"	16'-7"	14'-6"	12'-3"	15'-11"	13'-11"	11'-8"
	16		32'-4"	25'-8"	22'-5"	20'-0"	17'-6"	14'-9"	18'-2"	15'-11"	13'-5"	16'-11"	14'-9"	12'-5"	15'-11"	13'-11"	11'-8"	15'-1"	13'-2"	11'-1"	14'-5"	12'-7"	10'-8"
	24		28'-3"	22'-5"	19'-7"	17'-6"	15'-3"	12'-11"	15'-11"	13'-11"	11'-8"	14'-9"	12'-11"	10'-10"	13'-11"	12'-2"	10'-3"	13'-2"	11'-6"	9'-9"	12'-7"	11'-0"	9'-4"
3625250-43	12	33	29'-6"	23'-5"	20'-6"	18'-4"	16'-0"	13'-6"	16'-7"	14'-6"	12'-3"	15'-5"	13'-6"	11'-4"	14'-2"	12'-8"	10'-8"	13'-2"	12'-1"	10'-2"	12'-4"	11'-6"	9'-9"
	16		26'-10"	21'-3"	18'-7"	16'-7"	14'-6"	12'-3"	15'-1"	13'-2"	11'-2"	13'-6"	12'-3"	10'-4"	12'-4"	11'-6"	9'-9"	11'-5"	10'-11"	9'-3"	10'-8"	10'-6"	8'-10"
	24		23'-5"	18'-7"	16'-3"	14'-2"	12'-8"	10'-8"	12'-4"	11'-6"	9'-9"	11'-0"	10'-8"	9'-0"	10'-0"	8'-6"	9'-4"	9'-4"	8'-1"	8'-8"	8'-8"	7'-9"	6'-9"
3625250-54	12	33	31'-8"	25'-2"	21'-11"	19'-7"	17'-2"	14'-6"	17'-10"	15'-7"	13'-2"	16'-7"	14'-6"	12'-2"	15'-7"	13'-7"	11'-6"	14'-10"	12'-11"	10'-11"	13'-11"	12'-4"	10'-5"
	16		28'-9"	22'-10"	19'-11"	17'-10"	15'-7"	13'-2"	16'-2"	14'-2"	11'-11"	15'-0"	13'-2"	11'-1"	1								



## Curtain Wall – Limiting Wall Heights (Continued)

Stud Member	Spacing	Fy (ksi)	5 psf			15 psf			20 psf			25 psf			30 psf			35 psf			40 psf			
			L/120	L/240	L/360	L/120	L/240	L/360	L/120	L/240	L/360	L/120	L/240	L/360	L/120	L/240	L/360	L/120	L/240	L/360	L/120	L/240	L/360	
362S250-68	12	50	33'-11"	26'-11"	23'-6"	21'-0"	18'-5"	15'-6"	19'-1"	16'-8"	14'-1"	17'-9"	15'-6"	13'-1"	16'-8"	14'-7"	12'-4"	15'-10"	13'-0"	11'-8"	15'-2"	13'-3"	11'-2"	
	16		30'-10"	24'-6"	21'-5"	19'-1"	16'-8"	14'-1"	17'-4"	15'-2"	12'-10"	16'-1"	14'-1"	11'-11"	15'-2"	13'-3"	11'-2"	14'-5"	12'-7"	10'-7"	13'-9"	12'-0"	10'-2"	
	24		26'-11"	21'-5"	18'-8"	16'-8"	14'-7"	12'-4"	15'-2"	13'-3"	11'-2"	14'-1"	12'-4"	10'-5"	13'-3"	11'-7"	9'-9"	12'-7"	11'-0"	9'-3"	12'-0"	10'-6"	8'-10"	
362S250-97	12	50	37'-7"	29'-10"	26'-1"	23'-4"	20'-4"	17'-2"	21'-2"	18'-6"	15'-7"	19'-8"	17'-2"	14'-6"	18'-6"	16'-2"	13'-8"	17'-7"	15'-4"	12'-11"	16'-10"	14'-8"	12'-5"	
	16		34'-2"	27'-1"	23'-8"	21'-2"	18'-6"	15'-7"	19'-3"	16'-10"	14'-2"	17'-10"	15'-7"	13'-2"	16'-10"	14'-8"	12'-5"	16'-0"	13'-11"	11'-9"	15'-3"	13'-4"	11'-3"	
	24		29'-10"	23'-8"	20'-8"	18'-6"	16'-2"	13'-8"	16'-10"	14'-8"	12'-5"	15'-7"	13'-8"	11'-6"	14'-8"	12'-10"	10'-10"	13'-11"	12'-2"	10'-3"	13'-4"	11'-8"	9'-10"	
362S300-332	12	33	-	-	-	-	-	-	-	-	-	-	-	-	-	-	-	-	-	-	-	-	-	
	16		-	-	-	-	-	-	-	-	-	-	-	-	-	-	-	-	-	-	-	-	-	-
	24		-	-	-	-	-	-	-	-	-	-	-	-	-	-	-	-	-	-	-	-	-	-
362S300-432	12	33	-	-	-	-	-	-	-	-	-	-	-	-	-	-	-	-	-	-	-	-	-	
	16		-	-	-	-	-	-	-	-	-	-	-	-	-	-	-	-	-	-	-	-	-	-
	24		-	-	-	-	-	-	-	-	-	-	-	-	-	-	-	-	-	-	-	-	-	-
362S300-54	12	33	33'-1"	26'-3"	22'-11"	20'-6"	17'-11"	15'-1"	18'-8"	16'-3"	13'-9"	17'-4"	15'-1"	12'-9"	16'-3"	14'-3"	12'-0"	15'-3"	13'-6"	11'-5"	14'-3"	12'-11"	10'-11"	
	16		30'-1"	23'-10"	20'-10"	18'-8"	16'-3"	13'-9"	16'-11"	14'-10"	12'-6"	15'-7"	13'-9"	11'-7"	14'-3"	12'-11"	10'-11"	13'-2"	12'-3"	10'-4"	12'-4"	11'-9"	9'-11"	
	24		26'-3"	20'-10"	18'-3"	16'-3"	14'-3"	12'-0"	14'-3"	12'-11"	10'-11"	12'-9"	12'-0"	10'-1"	11'-8"	11'-3"	9'-6"	10'-9"	10'-9"	9'-1"	10'-1"	10'-1"	8'-8"	
362S300-54	12	50	32'-6"	25'-10"	22'-7"	20'-2"	17'-7"	14'-10"	18'-4"	16'-0"	13'-6"	17'-0"	14'-10"	12'-6"	16'-0"	14'-0"	11'-9"	13'-3"	11'-2"	14'-6"	12'-8"	10'-8"		
	16		29'-6"	23'-5"	20'-6"	18'-4"	16'-0"	13'-6"	16'-8"	14'-6"	12'-3"	15'-5"	13'-6"	11'-5"	14'-6"	12'-8"	10'-8"	13'-10"	12'-1"	10'-2"	13'-2"	11'-6"	9'-9"	
	24		25'-10"	20'-6"	17'-11"	16'-0"	14'-0"	11'-9"	14'-6"	12'-8"	10'-8"	13'-6"	11'-9"	9'-11"	12'-8"	11'-1"	9'-4"	12'-1"	10'-6"	8'-11"	11'-6"	10'-1"	8'-6"	
362S300-68	12	50	35'-4"	28'-1"	24'-6"	21'-11"	19'-2"	16'-2"	19'-11"	17'-5"	14'-8"	18'-6"	16'-2"	13'-7"	17'-5"	15'-2"	12'-10"	16'-6"	14'-5"	12'-2"	15'-10"	13'-10"	11'-8"	
	16		32'-1"	25'-6"	22'-3"	19'-11"	17'-5"	14'-8"	18'-1"	15'-10"	13'-4"	16'-9"	14'-8"	12'-4"	15'-10"	13'-10"	11'-8"	15'-0"	13'-1"	11'-1"	14'-4"	12'-6"	10'-7"	
	24		28'-1"	22'-3"	19'-5"	17'-5"	15'-2"	12'-10"	15'-10"	13'-10"	11'-8"	14'-8"	12'-10"	10'-10"	13'-10"	12'-1"	10'-2"	13'-1"	11'-5"	9'-8"	12'-6"	10'-11"	9'-3"	
362S300-97	12	50	39'-4"	31'-3"	27'-3"	24'-5"	21'-4"	18'-0"	22'-2"	19'-4"	16'-4"	20'-7"	18'-0"	15'-2"	19'-4"	16'-11"	14'-3"	18'-5"	16'-1"	13'-7"	17'-7"	15'-4"	13'-0"	
	16		35'-9"	28'-5"	24'-10"	22'-2"	19'-4"	16'-4"	20'-2"	17'-7"	14'-10"	18'-8"	16'-4"	13'-9"	17'-7"	15'-4"	13'-0"	16'-9"	14'-7"	12'-4"	16'-0"	14'-0"	11'-9"	
	24		31'-3"	24'-10"	21'-8"	19'-4"	16'-11"	14'-3"	17'-7"	15'-4"	13'-0"	16'-4"	14'-3"	12'-0"	15'-4"	13'-5"	11'-4"	14'-7"	12'-9"	10'-9"	14'-0"	12'-2"	10'-3"	
400S137-33	12	33	25'-1"	19'-11"	17'-5"	15'-4"	13'-7"	11'-6"	13'-4"	12'-4"	10'-5"	11'-11"	11'-6"	9'-8"	10'-10"	10'-9"	9'-1"	10'-1"	8'-8"	9'-5"	9'-5"	8'-3"		
	16		22'-10"	18'-1"	15'-10"	13'-4"	12'-4"	10'-5"	11'-6"	11'-3"	9'-6"	10'-4"	8'-9"	9'-5"	8'-3"	8'-9"	8'-9"	7'-10"	6'-8"	8'-2"	8'-2"	7'-6"		
	24		18'-10"	15'-10"	13'-10"	10'-10"	10'-9"	9'-1"	9'-5"	9'-5"	8'-3"	8'-5"	8'-5"	7'-8"	7'-8"	7'-8"	7'-3"	7'-1"	6'-10"	6'-8"	6'-8"	6'-7"		
400S137-43	12	33	27'-4"	21'-8"	18'-11"	16'-11"	14'-9"	12'-6"	15'-5"	13'-5"	11'-4"	14'-0"	12'-6"	10'-6"	12'-9"	11'-9"	9'-11"	11'-10"	11'-2"	9'-5"	11'-1"	10'-8"	9'-0"	
	16		24'-10"	19'-8"	17'-2"	15'-5"	13'-5"	11'-4"	13'-6"	12'-2"	10'-4"	12'-1"	11'-4"	9'-7"	11'-1"	10'-8"	9'-0"	10'-3"	10'-2"	8'-6"	9'-7"	9'-7"	8'-2"	
	24		21'-8"	17'-2"	15'-0"	12'-9"	11'-9"	9'-11"	11'-1"	10'-8"	9'-0"	9'-11"	9'-11"	8'-4"	9'-0"	9'-0"	7'-10"	8'-4"	8'-4"	7'-6"	7'-10"	7'-10"	7'-2"	
400S137-54	12	33	29'-3"	23'-3"	20'-3"	18'-1"	15'-10"	13'-4"	16'-6"	14'-5"	12'-2"	15'-3"	13'-4"	11'-3"	14'-4"	12'-7"	10'-7"	13'-4"	11'-11"	10'-1"	12'-5"	11'-5"	9'-8"	
	16		26'-7"	21'-1"	18'-5"	16'-6"	14'-5"	12'-2"	15'-0"	13'-1"	11'-0"	13'-7"	12'-2"	10'-3"	12'-5"	11'-5"	9'-8"	11'-6"	10'-10"	9'-2"	10'-9"	10'-4"	8'-9"	
	24		23'-3"	18'-5"	16'-1"	14'-4"	12'-7"	10'-7"	12'-5"	11'-5"	9'-8"	11'-1"	10'-7"	8'-11"	10'-1"	10'-0"	8'-5"	9'-4"	9'-4"	8'-0"	8'-9"	8'-9"	7'-8"	
400S137-54	12	50	29'-3"	23'-3"	20'-3"	18'-1"	15'-10"	13'-4"	16'-6"	14'-5"	12'-2"	15'-3"	13'-4"	11'-3"	14'-5"	12'-7"	10'-7"	13'-8"	11'-11"	10'-1"	13'-1"	11'-5"	9'-8"	
	16		26'-7"	21'-1"	18'-5"	16'-6"	14'-5"	12'-2"	15'-0"	13'-1"	11'-0"	13'-11"	12'-2"	10'-3"	13'-1"	11'-5"	9'-8"	12'-5"	10'-10"	9'-2"	11'-10"	10'-4"	8'-9"	
	24		23'-3"	18'-5"	16'-1"	14'-4"	12'-7"	10'-7"	12'-5"	11'-5"	9'-8"	11'-1"	10'-7"	8'-11"	10'-1"	10'-0"	8'-5"	9'-4"	9'-4"	8'-0"	8'-9"	8'-9"	7'-8"	
400S137-68	12	50	31'-3"	24'-10"	21'-8"	19'-5"	16'-11"	14'-3"	17'-7"	15'-5"	13'-0"	16'-4"	14'-3"	12'-1"	15'-5"	13'-4"	11'-4"	14'-7"	12'-9"	10'-9"	14'-0"	12'-2"	10'-4"	
	16		28'-5"	22'-7"	19'-8"	17'-7"	15'-5"	13'-0"	16'-0"	14'-0"	11'-9"	14'-10"	13'-0"	10'-11"	14'-0"	12'-2"	10'-4"	13'-3"	11'-7"	9'-9"	12'-8"	11'-1"	9'-4"	
	24		24'-10"	19'-8"	17'-2"	15'-5"	13'-5"	11'-4"	14'-0"	12'-2"	10'-4"	13'-0"	11'-4"	9'-7"	12'-2"	10'-8"	9'-0"	11'-3"	10'-2"	8'-7"	11'-1"	9'-8"	8'-2"	
400S162-33	12	33	26'-3"	20'-10"	18'-3"	16'-3"	14'-3"	12'-0"	14'-3"	12'-11"	10'-11"	12'-9"	12'-0"	10'-1"	11'-8"	11'-4"	9'-6"	10'-9"	10'-9"	9'-1"	10'-1"	10'-1"	8'-8"	
	16		23'-11"	18'-11"	16'-7"	14'-3"	12'-11"	10'-11"	12'-4"	11'-9"	9'-11"	11'-11"	9'-2"	10'-1"	10'-1"	8'-8"	9'-4"	9'-4"	8'-3"	8'-9"	8'-9"	8'-9"	7'-10"	
	24		20'-2"	16'-7"	14'-6"	11'-4"	9'-6"	10'-1"	10'-1"	8'-8"	9'-0"	9'-0"	8'-0"	8'-3"	7'-7"	7'-8"	7'-8"	7'-2"	6'-10"	6'-8"	6'-8"	6'-10"		
400S162-43	12	33	28'-7"	22'-8"	19'-10"	17'-9"	15'-6"	13'-1"	16'-1"	14'-1"	11'-10"	14'-11"	13'-1"	11'-0"	13'-9"	12'-3"	10'-4"	12'-8"	11'-8"	9'-10"	11'-11"	11'-2"	9'-5"	
	16		26'-0"	20'-7"	18'-0"	16'-1"	14'-1"	11'-10"	14'-7"	12'-9"	10'-9"	13'-0"	11'-10"	10'-0"	11'-11"	11'-2"	9'-5"	11'-0"	10'-7"	8'-11"	10'-5"	10'-2"	8'-7"	
	24		22'-8"	18'-0"	15'-9"	13'-9"	12'-3"	10'-4"	11'-11"	11'-2"	9'-5"	10'-8"	10'-4"	8'-9"	9'-8"	8'-3"	9'-0"	9'-0"	7'-10"	8'-3"	8'-5"	8'-5"	7'-6"	
400S162-54	12	33	30'-8"	24'-4"	21'-3"	19'-0"	16'-7"	14'-0"	17'-3"	15'-1"	12'-9"	16'-0"	14'-0"	11'-10"	15'-1"	13'-2"	11'-1"	14'-3"	12'-6"	10'-7"	13'-4"	12'-0"	10'-1"	
	16		27'-10"	22'-1"	19'-4"	17'-3"	15'-1"	12'-9"	15'-8"	13'-8"	11'-7"	14'-7"	12'-9"	10'-9"	13'-4"	12'-0"	10'-1"	12'-4"	11'-4"	9'-7"	11'-6"	10'-10"	9'-2"	
	24		24'-4"	19'-4"	16'-10"	15'-1"	13'-2"	11'-1"	13'-4"	12'-0"	10'-1"	11'-11"	9'-4"	10'-10"	10'-5"	8'-10"	10'-1"	11'-11"	9'-11"	8'-5"	9'-5"	9'-5"	8'-0"	
400S162-54	12	50	30'-8"	24'-4"	21'-3"	19'-0"	16'-7"	14'-0"	17'-3"	15'-1"	12'-9"	16'-0"	14'-0"	11'-10"	15'-1"	13'-2"	11'-1"	14'-4"	12'-6"	10'-7"	13'-8"	12'-0"	10'-1"	
	16		27'-10"	22'-1"	19'-4"	17'-3"	15'-1"	12'-9"	15'-8"	13'-8"	11'-7"	14'-7"	12'-9"	10'-9"	13'-8"	12'-0"	10'-1"	13'-0"	11'-4"	9'-7"	12'-5"	10'-10"	9'-2"	
	24		24'-4"	19'-4"	16'-10"	15'-1"	13'-2"	11'-1"	13'-8"	12'-0"	10'-1"	11'-2"	9'-4"	12'-0"	10'-5"	8'-10"	11'-4"	9'-11"	8'-5"	10'-10"	9'-6"	8'-0"		
400S162-68	12	50	32'-10"	26'-0"	22'-9"	20'-4"	17'-9"	15'-0"	18'-6"	16'-2"	13'-7"	17'-2"	15'-0"	12'-8"	16'-2"	14'-1"	11'-11"	15'-4"	13'-5"	11'-4"	14'-8"	12'-10"	10'-10"	
	16		29'-0"	23'-8"	20'-8"	18'-6"	16'-2"	13'-7"	16'-9"	14'-8"	12'-4"	15'-7"	13'-7"	11'-6"	14'-8"	12'-10"	10'-10"	13'-11"	12'-2"	10				

## Curtain Wall – Limiting Wall Heights (Continued)

Stud Member	Spacing	Fy (ksi)	5 psf			15 psf			20 psf			25 psf			30 psf			35 psf			40 psf						
			L/120	L/240	L/360	L/120	L/240	L/360	L/120	L/240	L/360	L/120	L/240	L/360	L/120	L/240	L/360	L/120	L/240	L/360	L/120	L/240	L/360				
400S250-33 <sup>2</sup>	12	33	-	-	-	-	-	-	-	-	-	-	-	-	-	-	-	-	-	-	-	-	-	-			
	16		-	-	-	-	-	-	-	-	-	-	-	-	-	-	-	-	-	-	-	-	-	-	-		
	24		-	-	-	-	-	-	-	-	-	-	-	-	-	-	-	-	-	-	-	-	-	-	-	-	
400S250-43	12	33	31'-9"	25'-3"	22'-0"	19'-8"	17'-2"	14'-6"	17'-11"	15'-8"	13'-2"	16'-6"	14'-6"	12'-3"	15'-1"	13'-8"	11'-6"	13'-11"	13'-0"	10'-11"	13'-0"	12'-5"	10'-6"	13'-0"	12'-5"	10'-6"	
	16		28'-10"	22'-11"	20'-0"	17'-11"	15'-8"	13'-2"	16'-0"	14'-2"	12'-0"	14'-3"	13'-2"	11'-1"	13'-0"	12'-5"	10'-6"	12'-1"	11'-9"	9'-11"	11'-3"	11'-3"	9'-6"	10'-6"	10'-6"	9'-6"	
	24		25'-3"	20'-0"	17'-6"	15'-1"	13'-8"	11'-6"	13'-0"	12'-5"	10'-6"	11'-8"	11'-6"	9'-9"	10'-8"	9'-2"	9'-10"	9'-10"	8'-8"	8'-8"	9'-3"	9'-3"	8'-4"	9'-3"	8'-4"	8'-4"	
400S250-54	12	33	34'-1"	27'-1"	23'-8"	21'-2"	18'-6"	15'-7"	19'-2"	16'-9"	14'-2"	17'-10"	15'-7"	13'-2"	16'-9"	14'-8"	12'-4"	15'-10"	13'-11"	11'-9"	14'-10"	13'-4"	11'-3"	14'-10"	13'-4"	11'-3"	
	16		31'-0"	24'-7"	21'-6"	19'-2"	16'-9"	14'-2"	17'-5"	15'-3"	12'-10"	16'-2"	14'-2"	11'-11"	14'-10"	13'-4"	11'-3"	13'-9"	12'-8"	10'-8"	12'-10"	12'-1"	10'-2"	12'-10"	12'-1"	10'-2"	
	24		27'-1"	21'-6"	18'-9"	16'-9"	14'-8"	12'-4"	14'-10"	13'-4"	11'-3"	13'-3"	12'-4"	10'-5"	12'-1"	11'-8"	9'-10"	11'-3"	11'-1"	9'-4"	10'-6"	10'-6"	8'-11"	10'-6"	10'-6"	8'-11"	
400S250-54	12	50	34'-1"	27'-0"	23'-7"	21'-1"	18'-5"	15'-7"	19'-2"	16'-9"	14'-1"	17'-10"	15'-7"	13'-1"	16'-9"	14'-8"	12'-4"	15'-11"	13'-11"	11'-9"	15'-3"	13'-4"	11'-3"	14'-10"	13'-4"	11'-3"	
	16		30'-11"	24'-7"	21'-5"	19'-2"	16'-9"	14'-1"	17'-5"	15'-3"	12'-10"	16'-2"	14'-1"	11'-11"	15'-3"	13'-4"	11'-3"	14'-5"	12'-8"	10'-8"	13'-10"	12'-1"	10'-2"	13'-10"	12'-1"	10'-2"	
	24		27'-0"	21'-5"	18'-9"	16'-9"	14'-8"	12'-4"	15'-3"	13'-4"	11'-3"	14'-1"	12'-4"	10'-5"	13'-4"	11'-7"	9'-10"	12'-8"	11'-0"	9'-4"	12'-1"	10'-7"	8'-11"	12'-1"	10'-7"	8'-11"	
400S250-68	12	50	36'-7"	29'-0"	25'-4"	22'-8"	19'-10"	16'-8"	20'-7"	18'-0"	15'-2"	19'-1"	16'-8"	14'-1"	18'-0"	15'-9"	13'-3"	17'-1"	14'-11"	12'-7"	16'-4"	14'-3"	12'-1"	16'-4"	14'-3"	12'-1"	
	16		33'-3"	26'-4"	23'-0"	20'-7"	18'-0"	15'-2"	18'-9"	16'-4"	13'-9"	17'-4"	15'-2"	12'-10"	16'-4"	14'-3"	12'-1"	15'-6"	13'-7"	11'-5"	14'-10"	13'-0"	10'-11"	14'-10"	13'-0"	10'-11"	
	24		29'-0"	23'-0"	20'-2"	18'-0"	15'-9"	13'-3"	16'-4"	14'-3"	12'-1"	15'-2"	13'-3"	11'-2"	14'-3"	12'-6"	10'-6"	13'-7"	11'-10"	10'-0"	13'-0"	11'-4"	9'-7"	13'-0"	11'-4"	9'-7"	
400S250-97	12	50	40'-7"	32'-2"	28'-1"	25'-2"	21'-11"	18'-6"	22'-10"	19'-11"	16'-10"	21'-2"	18'-6"	15'-7"	19'-11"	17'-5"	14'-8"	18'-11"	16'-7"	14'-0"	18'-2"	15'-10"	13'-4"	18'-2"	15'-10"	13'-4"	
	16		36'-10"	29'-3"	25'-7"	22'-10"	19'-11"	16'-10"	20'-9"	18'-2"	15'-3"	19'-3"	16'-10"	14'-2"	18'-2"	15'-10"	13'-4"	17'-3"	15'-0"	12'-8"	16'-6"	14'-5"	12'-2"	16'-6"	14'-5"	12'-2"	
	24		32'-2"	25'-7"	22'-4"	19'-11"	17'-5"	14'-8"	18'-2"	15'-10"	13'-4"	16'-10"	14'-8"	12'-5"	15'-10"	13'-10"	11'-8"	15'-0"	13'-2"	11'-1"	14'-5"	12'-7"	10'-7"	14'-5"	12'-7"	10'-7"	
400S300-33 <sup>2</sup>	12	33	-	-	-	-	-	-	-	-	-	-	-	-	-	-	-	-	-	-	-	-	-	-	-	-	
	16		-	-	-	-	-	-	-	-	-	-	-	-	-	-	-	-	-	-	-	-	-	-	-	-	-
	24		-	-	-	-	-	-	-	-	-	-	-	-	-	-	-	-	-	-	-	-	-	-	-	-	-
400S300-43 <sup>2</sup>	12	33	-	-	-	-	-	-	-	-	-	-	-	-	-	-	-	-	-	-	-	-	-	-	-	-	
	16		-	-	-	-	-	-	-	-	-	-	-	-	-	-	-	-	-	-	-	-	-	-	-	-	-
	24		-	-	-	-	-	-	-	-	-	-	-	-	-	-	-	-	-	-	-	-	-	-	-	-	-
400S300-54	12	33	35'-7"	28'-3"	24'-8"	22'-1"	19'-3"	16'-3"	20'-1"	17'-6"	14'-9"	18'-7"	16'-3"	13'-9"	17'-6"	15'-4"	12'-11"	16'-2"	14'-6"	12'-3"	15'-2"	13'-11"	11'-9"	15'-2"	13'-11"	11'-9"	
	16		32'-4"	25'-8"	22'-5"	20'-1"	17'-6"	14'-9"	18'-3"	15'-11"	13'-5"	16'-7"	14'-9"	12'-6"	15'-2"	13'-11"	11'-9"	14'-0"	13'-3"	11'-2"	13'-1"	12'-8"	10'-8"	13'-1"	12'-8"	10'-8"	
	24		28'-3"	22'-9"	19'-7"	17'-6"	15'-4"	12'-11"	15'-2"	13'-11"	11'-9"	13'-6"	12'-11"	10'-11"	12'-4"	12'-2"	10'-3"	11'-5"	11'-5"	9'-9"	10'-8"	10'-8"	9'-4"	10'-8"	10'-8"	9'-4"	
400S300-54	12	50	35'-0"	27'-5"	24'-3"	21'-8"	18'-11"	16'-0"	19'-8"	17'-3"	14'-6"	18'-3"	16'-0"	13'-6"	16'-0"	13'-6"	10'-7"	12'-8"	16'-4"	14'-3"	12'-1"	15'-8"	13'-8"	11'-6"	15'-8"	13'-8"	
	16		31'-9"	25'-3"	22'-1"	19'-8"	17'-3"	14'-6"	17'-11"	15'-8"	13'-2"	16'-7"	14'-6"	12'-3"	15'-8"	13'-8"	11'-6"	14'-10"	13'-0"	10'-11"	14'-3"	12'-5"	10'-6"	14'-3"	12'-5"	10'-6"	
	24		27'-9"	22'-1"	19'-3"	17'-3"	15'-0"	12'-8"	15'-8"	13'-8"	11'-6"	14'-6"	12'-8"	10'-8"	13'-8"	11'-11"	10'-1"	13'-0"	11'-4"	9'-7"	12'-4"	10'-10"	9'-2"	12'-4"	10'-10"	9'-2"	
400S300-68	12	50	38'-0"	30'-2"	26'-4"	23'-7"	20'-7"	17'-4"	21'-5"	18'-9"	15'-9"	19'-11"	17'-4"	14'-8"	18'-9"	16'-4"	13'-9"	17'-9"	15'-6"	13'-1"	17'-0"	14'-10"	12'-6"	17'-0"	14'-10"	12'-6"	
	16		34'-7"	27'-5"	24'-0"	21'-5"	18'-9"	15'-9"	19'-6"	17'-0"	14'-4"	18'-1"	15'-9"	13'-4"	17'-0"	14'-10"	12'-6"	16'-2"	14'-1"	11'-11"	15'-5"	13'-6"	11'-9"	15'-5"	13'-6"	11'-9"	
	24		30'-2"	24'-0"	20'-11"	18'-9"	16'-4"	13'-9"	17'-0"	14'-10"	12'-6"	15'-9"	13'-9"	11'-8"	14'-10"	13'-0"	10'-11"	14'-1"	12'-4"	10'-5"	13'-6"	11'-9"	9'-11"	13'-6"	11'-9"	9'-11"	
400S300-97	12	50	42'-5"	33'-8"	29'-5"	26'-3"	22'-11"	19'-4"	23'-10"	20'-10"	17'-7"	22'-2"	19'-4"	16'-4"	20'-10"	18'-3"	15'-4"	19'-10"	17'-4"	14'-7"	18'-11"	16'-7"	13'-11"	18'-11"	16'-7"	13'-11"	
	16		38'-6"	30'-7"	26'-8"	23'-10"	20'-10"	17'-7"	21'-8"	18'-11"	16'-0"	20'-2"	17'-7"	14'-10"	18'-11"	16'-7"	13'-11"	18'-0"	15'-9"	13'-3"	17'-3"	15'-0"	12'-8"	17'-3"	15'-0"	12'-8"	
	24		33'-8"	26'-8"	23'-4"	20'-10"	18'-3"	15'-4"	18'-11"	16'-7"	13'-11"	17'-7"	15'-4"	12'-11"	16'-7"	14'-5"	12'-2"	15'-9"	13'-9"	11'-7"	15'-0"	13'-2"	11'-1"	15'-0"	13'-2"	11'-1"	
550S162-33	12	33	33'-8"	26'-9"	23'-4"	20'-11"	18'-3"	15'-5"	18'-3"	16'-7"	14'-0"	16'-4"	15'-5"	13'-0"	14'-11"	14'-6"	12'-3"	13'-10"	13'-9"	11'-7"	12'-11"	12'-11"	11'-1"	12'-11"	12'-11"	11'-1"	
	16		30'-7"	24'-4"	21'-3"	18'-3"	16'-7"	14'-0"	15'-10"	15'-1"	12'-8"	14'-2"	14'-0"	11'-9"	12'-11"	12'-11"	12'-0"	12'-0"	10'-6"	11'-2"	11'-2"	10'-1"	11'-2"	11'-2"	10'-1"	10'-1"	
	24		25'-10"	21'-3"	18'-7"	14'-11"	14'-6"	12'-3"	12'-11"	12'-11"	11'-1"	11'-7"	11'-7"	10'-4"	10'-7"	10'-7"	9'-8"	9'-9"	9'-9"	9'-2"	9'-2"	9'-2"	8'-10"	9'-2"	8'-10"	8'-10"	
550S162-43	12	33	36'-8"	29'-1"	25'-5"	22'-9"	19'-10"	16'-9"	20'-8"	18'-1"	15'-3"	19'-2"	16'-9"	14'-2"	17'-11"	15'-9"	13'-4"	16'-7"	15'-0"	12'-8"	15'-6"	14'-4"	12'-1"	15'-6"	14'-4"	12'-1"	
	16		33'-4"	26'-5"	23'-1"	20'-8"	18'-1"	15'-3"	18'-9"	16'-5"	13'-10"	17'-0"	15'-3"	12'-10"	15'-6"	14'-4"	12'-1"	14'-4"	13'-7"	11'-6"	13'-5"	13'-0"	11'-0"	13'-5"	13'-0"	11'-0"	
	24		29'-1"	23'-1"	20'-2"	17'-11"	15'-9"	13'-4"	15'-6"	14'-4"	12'-1"	13'-11"	13'-4"	11'-3"	12'-8"	12'-6"	10'-7"	11'-9"	11'-9"	10'-0"	11'-0"	11'-0"	9'-7"	11'-0"	11'-0"	9'-7"	
550S162-54	12	33	39'-4"	31'-3"	27'-3"	24'-5"	21'-4"	18'-0"	22'-2"	19'-4"	16'-4"	20'-7"	18'-0"	15'-2"	19'-4"	16'-11"	14'-3"	18'-5"	16'-1"	13'-7"	17'-7"	15'-4"	13'-0"	17'-7"	15'-4"	13'-0"	
	16		35'-9"	28'-5"	24'-10"	22'-2"	19'-4"	16'-4"	20'-2"	17'-7"	14'-10"	18'-8"	16'-4"	13'-9"	17'-7"	15'-4"	13'-0"	16'-4"	14'-7"	12'-4"	15'-3"	14'-0"	11'-9"	15'-3"	14'-0"	11'-9"	
	24		31'-3"	24'-10"	21'-8"	19'-4"	16'-11"	14'-3"	17'-7"	15'-4"	13'-0"	15'-9"	14'-3"	12'-0"	14'-5"	13'-5"	11'-4"	13'-4"	12'-9"	10'-9"	12'-6"	12'-2"	10'-3"	12'-6"	12'-2"	10'-3"	
550S162-54	12	50	39'-4"	31'-3"	27'-3"	24'-5"	21'-4"	18'-0"	22'-2"	19'-4"	16'-4"	20'-7"	18'-0"	15'-2"	19'-4"	16'-11"	14'-3"	18'-5"	16'-1"	13'-7"	17'-7"	15'-4"	13'-0"	17'-7"	15'-4"	13'-0"	
	16		35'-9"	28'-5"	24'-10"	22'-2"	19'-4"	16'-4"	20'-2"	17'-7"	14'-10"	18'-8"	16'-4"	13'-9"	17'-7"	15'-4"	13'-0"	16'-4"	14'-7"	12'-4"	15'-3"	14'-0"	11'-9"	15'-3"	14'-0"	11'-9"	
	24		31'-3"	24'-10"	21'-8"	19'-4"	16'-11"	14'-3"	17'-7"	15'-4"	13'-0"	15'-9"	14'-3"	12'-0"	14'-5"	13'-5"	11'-4"	13'-4"	12'-9"	10'-9"	12'-6"	12'-2"	10'-3"	12'-6"	12'-2"	10'-3"	
550S162-68	12	50	42'-2"	33'-6"	29'-3"	26'-2"	22'-10"	19'-3"	23'-9"	20'-9"	17'-6"	22'-1"	19'-3"	16'-3"	20'-9"	18'-2"	15'-3"	19'-7"	17'-3"	14'-6"	18'-10"	16'-6"	13'-11"	18'-10"	16'-6"	13'-11"	
	16		38'-4"	30'-5"	26'-7"	23'-9"	20'-9"	17'-6"	21'-7"	18'-10"	15'-11"	20'-0"	17'-6"	14'-9"	18'-10"	16'-6"	13'-11"	17'-11"	15'-8"	13'-2"	17'-2"	15'-0"	12'-7"	17'-2"	15'-0"	12'-7"	
	24		33'-6"	26'-7"	23'-3"	20'-9"	18'-2"	15'-3"	18'-10"	16'-6"	13'-11"	17'-6"	15'-3"	12'-11"	16'-6"	14'-5"	12'-2"	15'-8"	13'-8"	11'-6"	15'-0"	13'-1"	11'-0"	15'-0"	13'-1"	11'-0"	
550S162-97	12	50	46'-9"	37'-1"	32'-5"	28'-11"	25'-4"	21'-4"	26'-4"	23'-0"	19'-5"	24'-5"	21'-4"	18'-0"	23'-0"	20'-1"	16'-11"	21'-10"	19'-1"	16'-1"	20'-11"	18'-3"	15'-5"	19'-1"	16'-1		

## Curtain Wall – Limiting Wall Heights (Continued)

Stud Member	Spacing	Fy (ksi)	5 psf			15 psf			20 psf			25 psf			30 psf			35 psf			40 psf				
			L/120	L/240	L/360	L/120	L/240	L/360	L/120	L/240	L/360	L/120	L/240	L/360	L/120	L/240	L/360	L/120	L/240	L/360	L/120	L/240	L/360		
600S162-43	12	33	37'-8"	29'-11"	26'-2"	23'-4"	20'-5"	17'-3"	20'-6"	18'-6"	15'-8"	18'-4"	17'-3"	14'-6"	16'-8"	16'-2"	13'-8"	15'-6"	13'-0"	14'-6"	14'-6"	12'-5"	14'-6"	12'-5"	
			34'-3"	27'-2"	23'-9"	20'-6"	18'-6"	15'-8"	17'-9"	16'-10"	14'-3"	15'-10"	15'-8"	13'-2"	14'-6"	14'-6"	12'-5"	13'-5"	13'-5"	11'-9"	12'-6"	12'-6"	11'-3"	11'-3"	
			28'-11"	23'-9"	20'-9"	16'-8"	16'-2"	13'-8"	14'-6"	14'-6"	12'-5"	12'-11"	12'-11"	11'-6"	11'-10"	11'-10"	10'-10"	10'-11"	10'-11"	10'-4"	10'-3"	10'-3"	9'-10"	9'-10"	
600S162-54	12	33	40'-5"	32'-1"	28'-0"	25'-1"	21'-11"	18'-5"	22'-9"	19'-11"	16'-9"	21'-2"	18'-5"	15'-7"	19'-11"	17'-4"	14'-8"	18'-11"	16'-6"	13'-11"	18'-1"	15'-9"	13'-4"	13'-4"	
			36'-9"	29'-2"	25'-6"	22'-9"	19'-11"	16'-9"	20'-8"	18'-1"	15'-3"	18'-1"	16'-9"	14'-2"	16'-6"	15'-9"	13'-4"	15'-3"	15'-0"	12'-8"	14'-3"	14'-3"	12'-1"	12'-1"	
			32'-1"	25'-6"	22'-3"	19'-1"	17'-4"	14'-8"	16'-6"	15'-9"	13'-4"	14'-9"	14'-8"	12'-4"	13'-6"	13'-6"	11'-8"	12'-6"	12'-6"	11'-1"	11'-8"	11'-8"	10'-7"	10'-7"	
600S162-54	12	50	40'-5"	32'-1"	28'-0"	25'-1"	21'-11"	18'-5"	22'-9"	19'-11"	16'-9"	21'-2"	18'-5"	15'-7"	19'-11"	17'-4"	14'-8"	18'-11"	16'-6"	13'-11"	18'-1"	15'-9"	13'-4"	13'-4"	
			36'-9"	29'-2"	25'-6"	22'-9"	19'-11"	16'-9"	20'-8"	18'-1"	15'-3"	19'-2"	16'-9"	14'-2"	18'-1"	15'-9"	13'-4"	17'-2"	15'-0"	12'-8"	16'-5"	14'-4"	12'-1"	12'-1"	
			32'-1"	25'-6"	22'-3"	19'-1"	17'-4"	14'-8"	18'-1"	15'-9"	13'-4"	16'-9"	14'-8"	12'-4"	13'-6"	13'-6"	11'-8"	12'-6"	12'-6"	11'-1"	11'-8"	11'-8"	10'-7"	10'-7"	
600S162-68	12	50	43'-4"	34'-4"	30'-0"	26'-10"	23'-5"	19'-9"	24'-5"	21'-4"	18'-0"	22'-8"	19'-9"	16'-8"	21'-4"	18'-7"	15'-8"	20'-3"	17'-8"	14'-11"	19'-4"	16'-11"	14'-3"	14'-3"	
			39'-4"	31'-3"	27'-3"	24'-5"	21'-4"	18'-0"	22'-2"	19'-4"	16'-4"	20'-7"	18'-0"	15'-2"	19'-4"	16'-11"	14'-3"	18'-5"	16'-1"	13'-7"	17'-7"	15'-4"	12'-11"	12'-11"	
			34'-4"	27'-3"	23'-10"	21'-4"	18'-7"	15'-8"	19'-4"	16'-11"	14'-3"	18'-0"	15'-8"	13'-3"	16'-11"	14'-9"	12'-5"	16'-1"	14'-0"	11'-10"	15'-4"	13'-5"	11'-4"	11'-4"	
600S162-97	12	50	47'-11"	38'-0"	33'-3"	29'-8"	25'-11"	21'-10"	27'-0"	23'-7"	19'-10"	25'-0"	21'-10"	18'-5"	23'-7"	20'-7"	17'-4"	22'-5"	19'-7"	16'-6"	21'-5"	18'-8"	15'-9"	15'-9"	
			43'-6"	34'-6"	30'-2"	27'-0"	23'-7"	19'-10"	24'-6"	21'-5"	18'-1"	22'-9"	19'-10"	16'-9"	21'-5"	18'-8"	15'-9"	20'-4"	17'-9"	15'-0"	19'-5"	17'-0"	14'-4"	14'-4"	
			38'-0"	30'-2"	26'-4"	23'-7"	20'-7"	17'-4"	21'-5"	18'-8"	15'-9"	19'-10"	17'-4"	14'-8"	18'-8"	16'-4"	13'-9"	17'-9"	15'-6"	13'-1"	17'-0"	14'-10"	12'-6"	12'-6"	
600S162-118	12	50	36'-1"	28'-8"	25'-0"	22'-4"	19'-7"	16'-6"	19'-5"	17'-9"	15'-0"	17'-5"	16'-6"	13'-11"	15'-10"	15'-6"	13'-1"	14'-8"	12'-5"	13'-9"	13'-9"	11'-11"	11'-11"		
			32'-9"	26'-0"	22'-9"	19'-5"	17'-9"	15'-0"	16'-10"	16'-2"	13'-7"	15'-1"	15'-0"	12'-8"	13'-9"	13'-9"	11'-11"	12'-9"	12'-9"	11'-3"	11'-11"	11'-11"	10'-10"	10'-10"	
			27'-6"	22'-9"	19'-10"	15'-10"	15'-6"	13'-1"	13'-9"	13'-9"	11'-11"	12'-3"	12'-3"	11'-0"	11'-3"	11'-3"	10'-5"	10'-5"	10'-5"	9'-10"	9'-9"	9'-9"	9'-5"	9'-5"	
600S200-33	12	33	39'-4"	31'-2"	27'-3"	24'-4"	21'-3"	17'-11"	22'-2"	19'-4"	16'-4"	20'-7"	17'-11"	15'-2"	19'-0"	16'-11"	14'-3"	17'-7"	16'-1"	13'-6"	16'-6"	15'-4"	12'-11"	12'-11"	
			35'-9"	28'-4"	24'-9"	22'-2"	19'-4"	16'-4"	20'-1"	17'-7"	14'-10"	18'-11"	16'-4"	13'-9"	16'-6"	15'-4"	12'-11"	15'-3"	14'-7"	12'-4"	14'-3"	13'-11"	11'-9"	11'-9"	
			31'-2"	24'-9"	21'-8"	19'-0"	16'-11"	14'-3"	16'-6"	15'-4"	12'-11"	14'-9"	14'-3"	12'-0"	13'-5"	13'-5"	11'-4"	12'-5"	12'-5"	10'-9"	11'-8"	11'-8"	10'-3"	10'-3"	
600S200-43	12	33	42'-2"	33'-6"	29'-3"	26'-2"	22'-10"	19'-3"	23'-9"	20'-9"	17'-6"	22'-1"	19'-3"	16'-3"	20'-9"	18'-1"	15'-3"	18'-7"	17'-3"	14'-6"	18'-9"	16'-6"	13'-11"	13'-11"	
			38'-4"	30'-5"	26'-7"	23'-9"	20'-9"	17'-6"	21'-7"	18'-10"	15'-11"	20'-0"	17'-6"	14'-9"	18'-9"	16'-6"	13'-11"	17'-4"	15'-8"	13'-2"	16'-3"	15'-0"	12'-7"	12'-7"	
			33'-6"	26'-7"	23'-3"	20'-9"	18'-1"	15'-3"	18'-9"	16'-6"	13'-11"	16'-9"	15'-3"	12'-11"	15'-4"	14'-5"	12'-2"	13'-8"	11'-6"	13'-3"	13'-1"	11'-0"	11'-0"	11'-0"	
600S200-54	12	33	42'-2"	33'-6"	29'-3"	26'-2"	22'-10"	19'-3"	23'-9"	20'-9"	17'-6"	22'-1"	19'-3"	16'-3"	20'-9"	18'-1"	15'-3"	18'-7"	17'-3"	14'-6"	18'-9"	16'-6"	13'-11"	13'-11"	
			38'-4"	30'-5"	26'-7"	23'-9"	20'-9"	17'-6"	21'-7"	18'-10"	15'-11"	20'-0"	17'-6"	14'-9"	18'-10"	16'-6"	13'-11"	17'-11"	15'-8"	13'-2"	17'-2"	15'-0"	12'-7"	12'-7"	
			33'-6"	26'-7"	23'-3"	20'-9"	18'-1"	15'-3"	18'-10"	16'-6"	13'-11"	17'-6"	15'-3"	12'-11"	16'-6"	14'-5"	12'-2"	13'-8"	11'-6"	15'-0"	13'-1"	11'-0"	11'-0"	11'-0"	
600S200-54	12	50	45'-3"	35'-11"	31'-4"	28'-0"	24'-6"	20'-8"	25'-6"	22'-3"	18'-9"	23'-8"	20'-8"	17'-5"	22'-3"	19'-5"	16'-5"	21'-2"	18'-6"	17'-5"	20'-3"	17'-8"	14'-11"	14'-11"	
			41'-1"	32'-7"	28'-6"	25'-6"	22'-3"	18'-9"	23'-2"	20'-3"	17'-1"	21'-6"	18'-9"	15'-10"	20'-3"	17'-8"	14'-11"	19'-2"	16'-9"	14'-2"	18'-4"	16'-0"	13'-6"	13'-6"	
			35'-11"	28'-6"	24'-11"	22'-3"	19'-5"	16'-5"	20'-3"	17'-8"	14'-11"	18'-9"	16'-5"	13'-10"	17'-8"	15'-5"	13'-0"	16'-9"	14'-8"	12'-4"	16'-0"	14'-0"	11'-10"	11'-10"	
600S200-68	12	50	50'-1"	39'-9"	34'-9"	31'-1"	27'-2"	22'-11"	28'-3"	24'-8"	20'-10"	26'-2"	22'-11"	19'-4"	24'-8"	21'-6"	18'-2"	23'-5"	20'-5"	17'-3"	22'-5"	19'-7"	16'-6"	16'-6"	
			45'-6"	36'-2"	31'-7"	28'-3"	24'-8"	20'-10"	25'-8"	22'-5"	18'-11"	23'-10"	20'-10"	17'-6"	22'-5"	19'-7"	17'-1"	14'-5"	18'-7"	16'-3"	13'-8"	20'-4"	17'-9"	15'-0"	15'-0"
			39'-9"	31'-7"	27'-7"	24'-8"	21'-6"	18'-2"	22'-5"	19'-7"	16'-6"	20'-10"	18'-2"	15'-4"	19'-7"	17'-1"	14'-5"	18'-7"	16'-3"	13'-8"	17'-9"	15'-6"	13'-1"	13'-1"	
600S200-97	12	50	52'-11"	42'-0"	36'-8"	32'-10"	28'-8"	24'-2"	29'-10"	26'-1"	22'-0"	27'-8"	24'-2"	20'-5"	26'-1"	22'-9"	19'-2"	24'-9"	21'-7"	18'-3"	23'-8"	20'-8"	17'-5"	17'-5"	
			48'-1"	38'-2"	33'-4"	29'-10"	26'-1"	22'-0"	27'-1"	23'-8"	19'-11"	25'-2"	22'-0"	18'-6"	23'-8"	20'-8"	17'-5"	22'-6"	19'-8"	16'-7"	21'-6"	18'-9"	15'-10"	15'-10"	
			42'-0"	33'-4"	29'-2"	26'-1"	22'-9"	19'-2"	23'-8"	20'-8"	17'-5"	22'-0"	19'-2"	16'-2"	20'-8"	18'-1"	15'-3"	19'-8"	17'-2"	14'-6"	18'-9"	16'-5"	13'-10"	13'-10"	
600S200-118	12	50	37'-10"	30'-0"	26'-3"	23'-2"	20'-6"	17'-3"	20'-1"	18'-7"	15'-8"	17'-11"	17'-3"	14'-7"	16'-4"	16'-3"	13'-8"	15'-2"	15'-2"	13'-0"	14'-2"	14'-2"	12'-5"	12'-5"	
			34'-4"	27'-3"	23'-10"	20'-1"	18'-7"	15'-8"	17'-4"	16'-11"	14'-3"	15'-6"	15'-6"	13'-3"	14'-2"	14'-2"	12'-5"	13'-1"	13'-1"	11'-10"	12'-3"	12'-3"	11'-4"	11'-4"	
			28'-4"	23'-10"	20'-10"	16'-4"	16'-3"	13'-8"	14'-2"	14'-2"	12'-5"	12'-8"	12'-8"	11'-7"	11'-7"	10'-11"	10'-11"	10'-9"	10'-9"	10'-4"	10'-0"	10'-0"	9'-11"	9'-11"	
600S250-43	12	33	41'-3"	32'-9"	28'-7"	25'-7"	22'-4"	18'-10"	23'-3"	20'-4"	17'-2"	21'-5"	18'-10"	15'-11"	19'-6"	17'-9"	15'-0"	18'-1"	16'-10"	14'-3"	16'-11"	16'-1"	13'-7"	13'-7"	
			37'-6"	29'-9"	26'-0"	23'-3"	20'-4"	17'-2"	20'-9"	18'-5"	15'-7"	18'-6"	17'-2"	14'-5"	16'-11"	16'-1"	13'-7"	15'-8"	15'-4"	12'-11"	14'-8"	14'-8"	12'-4"	12'-4"	
			32'-9"	26'-0"	22'-9"	19'-6"	17'-9"	15'-0"	16'-11"	16'-1"	13'-7"	15'-2"	15'-0"	12'-7"	13'-10"	13'-10"	11'-11"	12'-9"	12'-9"	11'-3"	12'-0"	12'-0"	10'-9"	10'-9"	
600S250-54	12	33	44'-4"	35'-2"	30'-9"	27'-6"	24'-0"	20'-3"	24'-11"	21'-10"	18'-5"	23'-2"	20'-3"	17'-1"	21'-10"	19'-1"	16'-1"	20'-9"	18'-1"	15'-3"	19'-10"	17'-4"	14'-7"	14'-7"	
			40'-3"	32'-0"	27'-11"	24'-11"	21'-10"	18'-5"	22'-8"	19'-10"	16'-8"	21'-1"	18'-5"	15'-6"	19'-10"	17'-4"	14'-7"	18'-6"	16'-5"	13'-10"	17'-4"	15'-9"	13'-3"	13'-3"	
			35'-2"	27'-11"	24'-5"	21'-10"	19'-1"	16'-1"	19'-10"	17'-4"	14'-7"	17'-10"	16'-1"	13'-7"	16'-4"	15'-1"	12'-9"	15'-1"	14'-4"	12'-1"	14'-2"	13'-9"	11'-7"	11'-7"	
600S250-54	12	50	44'-4"	35'-2"	30'-9"	27'-6"	24'-0"	20'-3"	24'-11"	21'-10"	18'-5"	23'-2"	20'-3"	17'-1"	21'-10"	19'-1"	16'-1"	20'-9"	18'-1"	15'-3"	19'-10"	17'-4"	14'-7"	14'-7"	
			40'-3"	32'-0"	27'-11"	24'-11"	21'-10"	18'-5"	22'-8"	19'-10"	16'-8"	21'-1"	18'-5"	15'-6"	19'-10"	17'-4"	14'-7"	18'-10"	16'-5"	13'-10"	18'-0"	15'-9"	13'-7"	13'-7"	
			35'-2"	27'-11"	24'-5"	21'-10"	19'-1"	16'-1"	19'-10"	17'-4"	14'-7"	18'-5"	16'-1"	13'-7"	17'-4"	15'-1"	12'-9"	16'-5"	14'-4"	12'-1"	15'-9"	13'-9"	11'-7"	11'-7"	
600S250-68	12	50	47'-7"	37'-9"	33'-0"	29'-6"	25'-9"	21'-9"	26'-9"	23'-5"	19'-9"	24'-10"	21'-9"	18'-4"	23'-5"	20'-5"	17'-3"	22'-3"	19'-5"	16'-4"	21'-3"	18'-7"	15'-8"	15'-8"	
			43'-2"	34'-4"	29'-11"	26'-9"	23'-5"	19'-9"	24'-4"	21'-3"	17'-11"	22'-7"	19'-9"	16'-8"	21'-3"	18'-7"	15'-8"	20'-2"	17'-8"	14'-11"	19'-4"	16'-10"	14'-3"	14'-3"	
			37'-9"	29'-11"	26'-2"	23'-5"	20'-5"	17'-3"	21'-3"	18'-7"	15'-8"	19'-9"	17'-3"	14'-6"	18'-7"	16'-3"	13'-8"	17'-8"	15'-5"	13'-0"	16'-10"	14'-9"	12'-5"	12'-5"	
600S250-97	12	50	52'-10"	41'-11"	36'-7"	32'-9"	28'-7"	24'-1"	29'-9"	26'-0"	21'-11"	27'-7"	24'-1"	20'-4"	26'-0"	22'-8"	19'-2"	24'-8"	21'-7"	18'-2"	23'-7"	20'-7"	17'-5"	17'-5"	
			48'-0"	38'-1"	33'-3"	29'-9"	26'-0"	21'-11"	27'-0"	23'-7"	19'-11"	25'-1"	21'-11"	18'-6"	23'-7"	20'-7"	17'-5"	22'-5"	19'-7"	16'-6"	21'-5"	18'-9"	15'-10"	15'-10"	
			41'-11"	33'-3"	29'-1"</																				

## Curtain Wall – Limiting Wall Heights (Continued)

Stud Member	Spacing	Fy (ksi)	5 psf			15 psf			20 psf			25 psf			30 psf			35 psf			40 psf		
			L/120	L/240	L/360	L/120	L/240	L/360	L/120	L/240	L/360	L/120	L/240	L/360	L/120	L/240	L/360	L/120	L/240	L/360	L/120	L/240	L/360
600S350-68	12	50	37'-8"	29'-11"	26'-2"	23'-4"	20'-5"	17'-3"	20'-6"	18'-6"	15'-8"	18'-4"	17'-3"	14'-6"	16'-8"	16'-2"	13'-8"	15'-6"	15'-5"	13'-0"	14'-6"	14'-6"	12'-5"
	16		34'-3"	27'-2"	23'-9"	20'-6"	18'-6"	15'-8"	17'-9"	16'-10"	14'-3"	15'-10"	15'-8"	13'-2"	14'-6"	14'-6"	12'-5"	13'-5"	13'-5"	11'-9"	12'-6"	12'-6"	11'-3"
	24		28'-11"	23'-9"	20'-9"	16'-8"	16'-2"	13'-8"	14'-6"	14'-6"	12'-5"	12'-11"	12'-11"	11'-6"	11'-10"	11'-10"	10'-10"	10'-11"	10'-11"	10'-4"	10'-3"	10'-3"	9'-10"
600S350-97	12	50	40'-5"	32'-1"	28'-0"	25'-1"	21'-11"	18'-5"	22'-9"	19'-11"	16'-9"	20'-10"	18'-5"	15'-7"	19'-1"	17'-4"	14'-8"	17'-8"	16'-6"	13'-11"	16'-6"	15'-9"	13'-4"
	16		36'-9"	29'-2"	25'-6"	22'-9"	19'-11"	16'-9"	20'-2"	18'-1"	15'-3"	18'-1"	16'-9"	14'-2"	16'-6"	15'-9"	13'-4"	15'-3"	15'-0"	12'-8"	14'-3"	14'-3"	12'-1"
	24		32'-1"	25'-6"	22'-3"	19'-1"	17'-4"	14'-8"	16'-6"	15'-9"	13'-4"	14'-9"	14'-8"	12'-4"	13'-6"	13'-6"	11'-8"	12'-6"	12'-6"	11'-1"	11'-8"	11'-8"	10'-7"
600S350-118	12	50	40'-5"	32'-1"	28'-0"	25'-1"	21'-11"	18'-5"	22'-9"	19'-11"	16'-9"	20'-10"	18'-5"	15'-7"	19'-1"	17'-4"	14'-8"	18'-11"	16'-6"	13'-11"	18'-1"	15'-9"	13'-4"
	16		36'-9"	29'-2"	25'-6"	22'-9"	19'-11"	16'-9"	20'-8"	18'-1"	15'-3"	19'-2"	16'-9"	14'-2"	18'-1"	15'-9"	13'-4"	17'-2"	15'-0"	12'-8"	16'-5"	14'-4"	12'-1"
	24		32'-1"	25'-6"	22'-3"	19'-11"	17'-4"	14'-8"	18'-1"	15'-9"	13'-4"	16'-9"	14'-8"	12'-4"	15'-9"	13'-9"	11'-8"	14'-9"	13'-1"	11'-1"	13'-10"	12'-6"	10'-7"
800S137-33 <sup>1</sup>	12	33	43'-4"	30'-4"	26'-10"	23'-5"	19'-9"	23'-5"	21'-4"	18'-0"	22'-2"	19'-4"	16'-4"	20'-7"	18'-0"	15'-2"	19'-4"	16'-11"	14'-3"	18'-5"	16'-1"	13'-7"	17'-7"
	16		39'-4"	31'-3"	27'-3"	24'-5"	21'-4"	18'-0"	22'-2"	19'-4"	16'-4"	20'-7"	18'-0"	15'-2"	19'-4"	16'-11"	14'-3"	18'-5"	16'-1"	13'-7"	17'-7"	15'-4"	12'-11"
	24		34'-4"	27'-3"	23'-10"	21'-4"	18'-7"	15'-8"	19'-4"	16'-11"	14'-3"	18'-0"	15'-8"	13'-3"	16'-11"	14'-9"	12'-5"	16'-1"	14'-0"	11'-10"	15'-4"	13'-5"	11'-4"
800S137-43	12	33	47'-11"	38'-0"	33'-3"	29'-8"	25'-11"	21'-10"	27'-0"	23'-7"	19'-10"	25'-0"	21'-10"	18'-5"	23'-7"	17'-4"	22'-5"	19'-7"	17'-4"	22'-5"	19'-7"	16'-10"	15'-9"
	16		43'-6"	34'-6"	30'-2"	27'-0"	23'-7"	19'-10"	24'-6"	21'-5"	18'-1"	22'-9"	19'-10"	16'-9"	21'-5"	18'-8"	15'-9"	20'-4"	17'-9"	15'-0"	19'-5"	17'-0"	14'-4"
	24		38'-0"	30'-2"	26'-4"	23'-7"	20'-7"	17'-4"	21'-5"	18'-8"	15'-9"	19'-10"	17'-4"	14'-8"	16'-4"	13'-9"	18'-9"	15'-6"	13'-1"	17'-0"	14'-10"	12'-6"	10'-7"
800S137-54	12	33	36'-1"	28'-8"	25'-0"	22'-4"	19'-7"	16'-6"	19'-5"	17'-9"	15'-0"	17'-5"	16'-6"	13'-11"	15'-10"	15'-6"	13'-1"	14'-8"	14'-8"	12'-5"	13'-9"	13'-9"	11'-11"
	16		32'-9"	26'-0"	22'-9"	19'-5"	17'-9"	15'-0"	16'-10"	16'-2"	13'-7"	15'-1"	15'-0"	12'-8"	13'-9"	13'-9"	11'-11"	12'-9"	12'-9"	11'-3"	11'-11"	11'-11"	10'-10"
	24		27'-6"	22'-9"	19'-10"	15'-10"	15'-6"	13'-1"	13'-9"	13'-9"	11'-11"	12'-3"	12'-3"	11'-0"	11'-3"	11'-3"	10'-5"	10'-5"	10'-5"	9'-10"	9'-9"	9'-9"	9'-5"
800S137-54	12	50	39'-4"	31'-2"	27'-3"	24'-4"	21'-3"	17'-11"	22'-2"	19'-4"	16'-4"	20'-7"	17'-11"	15'-2"	19'-0"	16'-11"	14'-3"	17'-7"	16'-1"	13'-6"	16'-6"	15'-4"	12'-11"
	16		35'-9"	28'-4"	24'-9"	22'-2"	19'-4"	16'-4"	20'-1"	17'-7"	14'-10"	18'-1"	16'-4"	13'-9"	16'-6"	15'-4"	12'-11"	15'-3"	14'-7"	12'-4"	14'-3"	13'-11"	11'-9"
	24		31'-2"	24'-9"	21'-8"	19'-0"	16'-11"	14'-3"	16'-6"	15'-4"	12'-11"	14'-9"	14'-3"	12'-0"	13'-5"	13'-5"	11'-4"	12'-5"	12'-5"	10'-9"	11'-8"	11'-8"	10'-3"
800S137-68	12	50	42'-2"	33'-6"	29'-3"	26'-2"	22'-10"	19'-3"	23'-9"	20'-9"	17'-6"	22'-1"	19'-3"	16'-3"	20'-9"	18'-1"	15'-3"	19'-8"	17'-3"	14'-6"	18'-9"	16'-6"	13'-11"
	16		38'-4"	30'-5"	26'-7"	23'-9"	20'-9"	17'-6"	21'-7"	18'-10"	15'-11"	20'-0"	17'-6"	14'-9"	18'-10"	16'-6"	13'-11"	17'-4"	15'-8"	13'-2"	16'-3"	15'-0"	12'-7"
	24		33'-6"	26'-7"	23'-3"	20'-9"	18'-1"	15'-3"	18'-9"	16'-6"	13'-11"	16'-9"	15'-3"	12'-11"	15'-4"	14'-5"	12'-2"	14'-2"	13'-8"	11'-6"	13'-3"	13'-1"	11'-0"
800S137-97	12	50	42'-2"	33'-6"	29'-3"	26'-2"	22'-10"	19'-3"	23'-9"	20'-9"	17'-6"	22'-1"	19'-3"	16'-3"	20'-9"	18'-1"	15'-3"	19'-8"	17'-3"	14'-6"	18'-10"	16'-6"	13'-11"
	16		38'-4"	30'-5"	26'-7"	23'-9"	20'-9"	17'-6"	21'-7"	18'-10"	15'-11"	20'-0"	17'-6"	14'-9"	18'-10"	16'-6"	13'-11"	17'-11"	15'-8"	13'-2"	17'-2"	15'-0"	12'-7"
	24		33'-6"	26'-7"	23'-3"	20'-9"	18'-1"	15'-3"	18'-10"	16'-6"	13'-11"	16'-9"	15'-3"	12'-11"	15'-4"	14'-5"	12'-2"	15'-8"	13'-8"	11'-6"	15'-0"	13'-1"	11'-0"
800S162-33 <sup>1</sup>	12	33	45'-3"	35'-11"	31'-4"	28'-0"	24'-6"	20'-8"	25'-6"	22'-3"	18'-9"	23'-8"	20'-8"	17'-5"	22'-3"	19'-5"	16'-5"	21'-2"	18'-6"	15'-7"	20'-3"	17'-8"	14'-11"
	16		41'-1"	32'-7"	28'-6"	25'-3"	22'-3"	18'-9"	23'-2"	20'-3"	17'-1"	21'-6"	18'-9"	15'-10"	20'-3"	17'-8"	14'-11"	19'-2"	16'-9"	14'-2"	18'-4"	16'-0"	13'-6"
	24		35'-11"	28'-6"	24'-11"	22'-6"	19'-5"	16'-5"	20'-3"	17'-8"	14'-11"	18'-9"	16'-5"	13'-10"	17'-8"	15'-5"	13'-0"	16'-9"	14'-8"	12'-4"	16'-0"	14'-0"	11'-10"
800S162-43	12	33	50'-1"	39'-9"	34'-9"	31'-1"	27'-2"	22'-11"	28'-3"	24'-8"	20'-10"	26'-2"	22'-11"	19'-4"	24'-8"	21'-6"	18'-2"	23'-5"	20'-5"	17'-3"	22'-5"	19'-7"	16'-6"
	16		45'-6"	36'-2"	31'-7"	28'-3"	24'-8"	20'-10"	25'-8"	22'-5"	18'-11"	23'-10"	20'-10"	17'-6"	22'-5"	19'-7"	16'-6"	21'-3"	18'-7"	15'-8"	20'-4"	17'-9"	15'-0"
	24		39'-9"	31'-7"	27'-7"	24'-8"	21'-6"	18'-2"	22'-5"	19'-7"	16'-6"	20'-10"	18'-2"	15'-4"	19'-7"	17'-1"	14'-5"	18'-7"	16'-3"	13'-8"	17'-9"	15'-6"	13'-1"
800S162-54	12	50	52'-11"	42'-0"	36'-8"	32'-10"	28'-8"	24'-2"	29'-10"	26'-1"	22'-0"	27'-8"	24'-2"	20'-5"	26'-1"	22'-9"	19'-2"	24'-9"	21'-7"	18'-3"	23'-8"	20'-8"	17'-5"
	16		48'-1"	38'-2"	33'-4"	29'-10"	26'-1"	22'-0"	27'-1"	23'-8"	19'-11"	25'-2"	22'-0"	18'-6"	23'-8"	20'-8"	17'-5"	22'-6"	19'-8"	16'-7"	21'-6"	18'-9"	15'-10"
	24		42'-0"	33'-4"	29'-2"	26'-1"	22'-9"	19'-2"	23'-8"	20'-8"	17'-5"	22'-0"	19'-2"	16'-2"	20'-8"	18'-1"	15'-3"	19'-8"	17'-2"	14'-6"	18'-9"	16'-5"	13'-10"
800S162-68	12	50	41'-3"	32'-9"	28'-7"	25'-7"	22'-4"	18'-10"	23'-3"	20'-4"	17'-2"	21'-5"	18'-10"	15'-11"	19'-6"	17'-9"	15'-0"	18'-1"	16'-10"	14'-3"	16'-11"	16'-1"	13'-7"
	16		37'-6"	29'-9"	26'-0"	23'-3"	20'-4"	17'-2"	20'-9"	18'-5"	15'-7"	18'-6"	17'-2"	14'-5"	16'-11"	16'-1"	13'-7"	15'-8"	15'-4"	12'-11"	14'-8"	14'-8"	12'-4"
	24		32'-9"	26'-0"	22'-9"	19'-6"	17'-9"	15'-0"	16'-11"	16'-1"	13'-7"	15'-2"	15'-0"	12'-7"	13'-10"	13'-10"	11'-11"	12'-9"	12'-9"	12'-0"	12'-0"	12'-0"	10'-9"
800S162-97	12	50	44'-4"	35'-2"	30'-9"	27'-6"	24'-0"	20'-3"	24'-11"	21'-10"	18'-5"	23'-2"	20'-3"	17'-1"	21'-10"	19'-1"	16'-1"	20'-9"	18'-1"	15'-3"	19'-10"	17'-4"	14'-7"
	16		40'-3"	32'-0"	27'-11"	24'-11"	21'-10"	18'-5"	22'-8"	19'-10"	16'-8"	21'-1"	18'-5"	15'-6"	19'-10"	17'-4"	14'-7"	18'-6"	16'-5"	13'-10"	17'-4"	15'-9"	13'-3"
	24		35'-2"	27'-11"	24'-5"	21'-10"	19'-1"	16'-1"	19'-10"	17'-4"	14'-7"	17'-10"	16'-1"	13'-7"	16'-4"	15'-1"	12'-9"	15'-1"	14'-4"	12'-1"	14'-2"	13'-9"	11'-7"
800S162-118	12	50	44'-4"	35'-2"	30'-9"	27'-6"	24'-0"	20'-3"	24'-11"	21'-10"	18'-5"	23'-2"	20'-3"	17'-1"	21'-10"	19'-1"	16'-1"	20'-9"	18'-1"	15'-3"	19'-10"	17'-4"	14'-7"
	16		40'-3"	32'-0"	27'-11"	24'-11"	21'-10"	18'-5"	22'-8"	19'-10"	16'-8"	21'-1"	18'-5"	15'-6"	19'-10"	17'-4"	14'-7"	18'-10"	16'-5"	13'-10"	18'-0"	15'-9"	13'-3"
	24		35'-2"	27'-11"	24'-5"	21'-10"	19'-1"	16'-1"	19'-10"	17'-4"	14'-7"	18'-5"	16'-1"	13'-7"	17'-4"	15'-1"	12'-9"	16'-5"	14'-4"	12'-1"	15'-9"	13'-9"	11'-7"
800S200-33 <sup>1</sup>	12	33	47'-7"	37'-9"	33'-0"	29'-6"	25'-9"	21'-9"	26'-9"	23'-5"	19'-9"	24'-10"	21'-9"	18'-4"	23'-5"	20'-5"	17'-3"	22'-3"	19'-5"	16'-4"	21'-3"	18'-7"	15'-8"
	16		43'-2"	34'-4"	29'-11"	26'-9"	23'-5"	19'-9"	24'-4"	21'-3"	17'-11"	22'-7"	19'-9"	16'-8"	21'-3"	18'-7"	15'-8"	20'-2"	17'-8"	14'-11"	19'-4"	16'-10"	14'-3"
	24		37'-9"	29'-11"	26'-2"	23'-5"	20'-5"	17'-3"	21'-3"	18'-7"	15'-8"	19'-9"	17'-3"	14'-6"	18'-7"	16'-3"	13'-8"	17'-8"	15'-5"	13'-0"	16'-10"	14'-9"	12'-5"
800S200-43	12	33	52'-10"	41'-11"	36'-7"	32'-9"	28'-7"	24'-1"	29'-9"	26'-0"	21'-11"	27'-7"	24'-1"	20'-4"	26'-0"	22'-8"	19'-2"	24'-8"	21'-7"	18'-2"	23'-7"	20'-7"	17'-5"
	16		48'-0"	38'-1"	33'-3"	29'-9"	26'-0"	21'-11"	27'-0"	23'-7"	19'-11"	25'-1"	21'-11"	18'-6"	23'-7"	20'-7"	17'-5"	22'-5"	19'-7"	16'-6"	21'-5"	18'-9"	15'-10"
	24		41'-11"	33'-3"	29'-1"	26'-0"	22'-8"	19'-2"	23'-7"	20'-7"	17'-5"	21'-11"	19'-2"	16'-2"	20'-7"	18'-0"	15'-2"	19'-7"	17'-1"	14'-5"	18'-9"	16'-4"	13'-10"
800S200-54	12	33	55'-10"	44'-4"	38'-9"	34'-7"	30'-3"	25'-6"	31'-5"	27'-6"	23'-2"	29'-2"	25'-6"	21'-6"	27'-6"	24'-0"	20'-3"	26'-1"	22'-10"	19'-3"	25'-0"	21'-10"	18'-5"
	16		50'-9"	40'-3"	35'-2"	31'-5"	27'-6"	23'-2"	28'-7"	25'-0"	21'-1"	26'-6"	23'-2"	19'-7"	25'-0"	21'-10"	18'-5"	23'-9"	20'-9"	17'-6"	22'-8"	19'-10"	16'-9"
	24		44'-4"	35'-2"	30'-9"	27'-6"	24'-0"	20'-3"	25'-0"	21'-10"	18'-5"	23'-2"	20'-3"	17'-1"	21'-10"	19'-1"	16'-1"	20'-9"	18'-1"	15'-3"	19'-10"	17'-4"	14'-7"
800S200-54	12	50	43'-3"	34'-4"	30																		

## Curtain Wall – Limiting Wall Heights (Continued)

Stud Member	Spacing	Fy (ksi)	5 psf			15 psf			20 psf			25 psf			30 psf			
			L/120	L/240	L/360	L/120	L/240	L/360	L/120	L/240	L/360	L/120	L/240	L/360	L/120	L/240	L/360	L/120
800S250-54	12	50	37'-8"	29'-11"	26'-2"	23'-4"	20'-5"	17'-3"	20'-6"	18'-6"	15'-8"	18'-4"	17'-3"	14'-6"	16'-8"	16'-2"	13'-8"	15'-6"
	16		34'-3"	27'-2"	23'-9"	20'-6"	18'-6"	15'-8"	17'-9"	16'-10"	14'-3"	15'-10"	15'-8"	13'-2"	14'-6"	14'-6"	12'-5"	13'-5"
	24		28'-11"	23'-9"	20'-9"	16'-8"	16'-2"	13'-8"	14'-6"	14'-6"	12'-5"	12'-11"	12'-11"	11'-6"	11'-10"	11'-10"	10'-10"	10'-11"
800S250-68	12	50	40'-5"	32'-1"	28'-0"	25'-1"	21'-11"	18'-5"	22'-9"	19'-11"	16'-9"	20'-10"	18'-5"	15'-7"	19'-1"	17'-4"	14'-8"	17'-8"
	16		36'-9"	29'-2"	25'-6"	22'-9"	19'-11"	16'-9"	20'-2"	18'-1"	15'-3"	18'-1"	16'-9"	14'-2"	16'-6"	15'-9"	13'-4"	15'-3"
	24		32'-1"	25'-6"	22'-3"	19'-1"	17'-4"	14'-8"	16'-6"	15'-9"	13'-4"	14'-9"	14'-8"	12'-4"	13'-6"	13'-6"	11'-8"	12'-6"
800S250-97	12	50	40'-5"	32'-1"	28'-0"	25'-1"	21'-11"	18'-5"	22'-9"	19'-11"	16'-9"	21'-2"	18'-5"	15'-7"	19'-11"	17'-4"	14'-8"	18'-11"
	16		36'-9"	29'-2"	25'-6"	22'-9"	19'-11"	16'-9"	20'-8"	18'-1"	15'-3"	19'-2"	16'-9"	14'-2"	18'-1"	15'-9"	13'-4"	17'-2"
	24		32'-1"	25'-6"	22'-3"	19'-11"	17'-4"	14'-8"	18'-1"	15'-9"	13'-4"	16'-9"	14'-8"	12'-4"	15'-9"	13'-9"	11'-8"	14'-9"
800S250-118	12	50	43'-4"	34'-4"	30'-0"	26'-10"	23'-5"	19'-9"	24'-5"	21'-4"	18'-0"	22'-8"	19'-9"	16'-8"	21'-4"	18'-7"	15'-8"	20'-3"
	16		39'-4"	31'-3"	27'-3"	24'-5"	21'-4"	18'-0"	22'-2"	19'-4"	16'-4"	20'-7"	18'-0"	15'-2"	19'-4"	16'-11"	14'-3"	18'-5"
	24		34'-4"	27'-3"	23'-10"	21'-4"	18'-7"	15'-8"	19'-4"	16'-11"	14'-3"	18'-0"	15'-8"	13'-3"	16'-11"	14'-9"	12'-5"	16'-1"
800S300-54	12	50	47'-11"	38'-0"	33'-3"	29'-8"	25'-11"	21'-10"	27'-0"	23'-7"	19'-10"	25'-0"	21'-10"	18'-5"	23'-7"	20'-7"	17'-4"	22'-5"
	16		43'-6"	34'-6"	30'-2"	27'-0"	23'-7"	19'-10"	24'-6"	21'-5"	18'-1"	22'-9"	19'-10"	16'-9"	21'-8"	18'-5"	15'-8"	20'-3"
	24		38'-0"	30'-2"	26'-4"	23'-7"	20'-7"	17'-4"	21'-5"	18'-8"	15'-9"	19'-10"	17'-4"	14'-8"	18'-8"	16'-4"	13'-9"	17'-9"
800S300-68	12	50	36'-1"	28'-8"	25'-0"	22'-4"	19'-7"	16'-6"	19'-5"	17'-9"	15'-0"	17'-5"	16'-6"	13'-11"	15'-10"	15'-6"	13'-1"	14'-8"
	16		32'-9"	26'-0"	22'-9"	19'-5"	17'-9"	15'-0"	16'-10"	16'-2"	13'-7"	15'-1"	15'-0"	12'-8"	13'-9"	13'-9"	11'-11"	12'-9"
	24		27'-6"	22'-9"	19'-10"	15'-10"	15'-6"	13'-1"	13'-9"	13'-9"	11'-11"	12'-3"	12'-3"	11'-0"	11'-3"	11'-3"	10'-5"	10'-5"
800S300-97	12	50	39'-4"	31'-2"	27'-3"	24'-4"	21'-3"	17'-11"	22'-2"	19'-4"	16'-4"	20'-7"	17'-11"	15'-2"	19'-0"	16'-11"	14'-3"	17'-7"
	16		35'-9"	28'-4"	24'-9"	22'-2"	19'-4"	16'-4"	20'-1"	17'-7"	14'-10"	18'-1"	16'-4"	13'-9"	16'-6"	15'-4"	12'-11"	15'-3"
	24		31'-2"	24'-9"	21'-8"	19'-0"	16'-11"	14'-3"	16'-6"	15'-4"	12'-11"	14'-9"	14'-3"	12'-0"	13'-5"	13'-5"	11'-4"	12'-5"
800S300-118	12	50	42'-2"	33'-6"	29'-3"	26'-2"	22'-10"	19'-3"	23'-9"	20'-9"	17'-6"	22'-1"	19'-3"	16'-3"	20'-9"	18'-1"	15'-3"	19'-8"
	16		38'-4"	30'-5"	26'-7"	23'-9"	20'-9"	17'-6"	21'-7"	18'-10"	15'-11"	20'-0"	17'-6"	14'-9"	18'-9"	16'-6"	13'-11"	17'-4"
	24		33'-6"	26'-7"	23'-3"	20'-9"	18'-1"	15'-3"	18'-9"	16'-6"	13'-11"	16'-9"	15'-3"	12'-11"	15'-4"	14'-5"	12'-2"	14'-2"
800S350-54	12	50	42'-2"	33'-6"	29'-3"	26'-2"	22'-10"	19'-3"	23'-9"	20'-9"	17'-6"	22'-1"	19'-3"	16'-3"	20'-9"	18'-1"	15'-3"	19'-8"
	16		38'-4"	30'-5"	26'-7"	23'-9"	20'-9"	17'-6"	21'-7"	18'-10"	15'-11"	20'-0"	17'-6"	14'-9"	18'-10"	16'-6"	13'-11"	17'-11"
	24		33'-6"	26'-7"	23'-3"	20'-9"	18'-1"	15'-3"	18'-10"	16'-6"	13'-11"	17'-6"	15'-3"	12'-11"	16'-6"	14'-5"	12'-2"	15'-8"
800S350-68	12	50	45'-3"	35'-11"	31'-4"	28'-0"	24'-6"	20'-8"	25'-6"	22'-3"	18'-9"	23'-8"	20'-8"	17'-5"	22'-3"	19'-5"	16'-5"	21'-2"
	16		41'-1"	32'-7"	28'-6"	25'-6"	22'-3"	18'-9"	23'-2"	20'-3"	17'-1"	21'-6"	18'-9"	15'-10"	20'-3"	17'-8"	14'-11"	19'-2"
	24		35'-11"	28'-6"	24'-11"	22'-3"	19'-5"	16'-5"	20'-3"	17'-8"	14'-11"	18'-9"	16'-5"	13'-10"	17'-8"	15'-5"	13'-0"	16'-9"
800S350-97	12	50	50'-1"	39'-9"	34'-9"	31'-1"	27'-2"	22'-11"	28'-3"	24'-8"	20'-10"	26'-2"	22'-11"	19'-4"	24'-8"	21'-6"	18'-2"	23'-5"
	16		45'-6"	36'-2"	31'-7"	28'-3"	24'-8"	20'-10"	25'-8"	22'-5"	18'-11"	23'-10"	20'-10"	17'-6"	22'-5"	19'-7"	16'-6"	21'-3"
	24		39'-9"	31'-7"	27'-7"	24'-8"	21'-6"	18'-2"	22'-5"	19'-7"	16'-6"	20'-10"	18'-2"	15'-4"	19'-7"	17'-1"	14'-5"	18'-7"
800S350-118	12	50	52'-11"	42'-0"	36'-8"	32'-10"	28'-8"	24'-2"	29'-10"	26'-1"	22'-0"	27'-8"	24'-2"	20'-5"	26'-1"	22'-9"	19'-2"	24'-9"
	16		48'-1"	38'-2"	33'-4"	29'-10"	26'-1"	22'-0"	27'-1"	23'-8"	19'-11"	25'-2"	22'-0"	18'-6"	23'-8"	20'-8"	17'-5"	22'-6"
	24		42'-0"	33'-4"	29'-2"	26'-1"	22'-9"	19'-2"	23'-8"	20'-8"	17'-5"	22'-0"	19'-2"	16'-2"	20'-8"	18'-1"	15'-3"	19'-8"

## Combined Axial and Lateral Load Tables

1. Allowable axial loads listed in kips (1 kip = 1000 pounds).
2. Allowable axial loads determined in accordance with AISI S240-20, assuming that all axial loads pass through the geometric center of the section.
3. Listed lateral pressures and axial loads have not been modified for load combinations or allowable stress increases based on wind/earthquake or multiple transient loads.
4. Allowable axial loads based on lateral and torsional bracing at a maximum spacing of 4 feet on center.
5. The 5 psf live load has not been reduced for deflection checks. For 15 psf or higher wind pressure, read the note below:

IBC 2021/ASCE 7-16: Due to the change in the model building codes, design wind pressures determined using IBC 2021/ASCE 7-16 are strength level loads (LRFD) in comparison to those determined in some earlier IBC codes which were service level loads (ASD). The load/span tables that follow are based on service level (ASD) wind loads. Therefore, to properly use the load/span tables in this catalog, multiply the IBC 2021/ASCE 7-16 design wind pressures by 0.6 (Reference Section 2.4 ASCE 7-16) prior to entering the load/span tables.

Example:

- ASCE 7-16 Calculated Design Wind Pressure = 25 psf (Strength level loads, LRFD)
- Convert to service level loads (ASD) = 25 psf x 0.6 = 15 psf
- Use 15 psf as the Pressure Value used in this Table to determine the member span

Any Other Building Code: The load/span tables that follow are based on service level (ASD) wind loads. If the wind load being used meets this criterion, it does not need to be modified prior to using the tables.

6. Studs are assumed to be adequately braced at a maximum spacing of  $L_u$  to develop full allowable moment,  $M_a$ .
7. End supports have not been checked for web crippling. Refer web crippling capacity tables.
8. All tables are based on simple (single) span.
9. Cells marked with an “ \* ” have  $h/t > 200$ , thus requires bearing stiffeners. Cells are left blank when  $h/t > 260$ .
10. Cells marked with an a, b, c, d, e, or f meets  $L/720$ ,  $L/600$ ,  $L/480$ ,  $L/360$ ,  $L/240$ , or  $L/120$  respectively. Blank cells do not meet  $L/120$ .
11. Stud distortional buckling moment based on assumed  $K_\phi = 0$
12. Moment of inertia for deflection is optimized based on the maximum moment at service loads for the listed spans; therefore span values may be greater than spans based on effective moment of inertia listed in section property tables.

## 5 psf Lateral Load (Interior Walls Only)

Wall Height (ft)	Spacing (in.) o.c.	362S137-(mils)				362S162-(mils)					362S200-(mils)				362S250-(mils)				
		33 ksi		50 ksi		33 ksi		50 ksi			33 ksi		50 ksi		33 ksi		50 ksi		
		33	43	54	68	33	43	54	68	97	97	33	54	68	97	43	54	68	97
8	12	1.46 a	2.08 a	3.11 a	4.05 a	1.86 a	2.52 a	3.98 a	5.11 a	7.48 a	2.26 a	3.26 a	5.05 a	7.99 a	9.2 a	3.72 a	5.74 a	7.52 a	10.57 a
	16	1.4 a	2.02 a	3.07 a	4.01 a	1.8 a	2.46 a	3.93 a	5.07 a	7.43 a	2.2 a	3.2 a	5 a	7.92 a	9.15 a	3.65 a	5.68 a	7.46 a	10.51 a
	24	1.29 a	1.91 a	2.98 a	3.93 a	1.68 a	2.35 a	3.84 a	4.98 a	7.35 a	2.06 a	3.07 a	4.88 a	7.79 a	9.06 a	3.51 a	5.55 a	7.34 a	10.41 a
9	12	1.38 a	1.98 a	2.93 a	3.82 a	1.75 a	2.38 a	3.74 a	4.78 a	6.97 a	2.14 a	3.09 a	4.72 a	7.48 a	8.54 a	3.56 a	5.44 a	7 a	9.83 a
	16	1.31 a	1.91 a	2.88 a	3.78 a	1.68 a	2.31 a	3.68 a	4.73 a	6.92 a	2.06 a	3.01 a	4.65 a	7.4 a	8.49 a	3.47 a	5.36 a	6.93 a	9.77 a
	24	1.17 a	1.78 a	2.77 a	3.68 a	1.53 a	2.17 a	3.56 a	4.63 a	6.81 a	1.9 a	2.85 a	4.52 a	7.24 a	8.38 a	3.3 a	5.22 a	6.79 a	9.64 a
10	12	1.28 a	1.87 a	2.72 a	3.55 a	1.63 a	2.09 a	3.47 a	4.42 a	6.41 a	2.01 a	2.9 a	4.35 a	6.88 a	7.83 a	3.38 a	5.1 a	6.43 a	9.05 a
	16	1.2 a	1.79 a	2.66 a	3.5 a	1.54 a	2.02 a	3.4 a	4.36 a	6.35 a	1.91 a	2.81 a	4.27 a	6.79 a	7.77 a	3.28 a	5.01 a	6.35 a	8.97 a
	24	1.04 a	1.62 a	2.54 a	3.39 a	1.37 a	1.86 a	3.26 a	4.24 a	6.23 a	1.72 a	2.62 a	4.12 a	6.61 a	7.64 a	3.08 a	4.84 a	6.2 a	8.83 a
12	12	1.08 a	1.6 a	2.29 a	2.98 a	1.37 a	1.99 a	2.84 a	3.62 a	5.2 a	1.71 a	2.48 a	3.54 a	5.58 a	6.33 a	2.91 a	4.17 a	5.25 a	7.39 a
	16	0.97 b	1.5 a	2.21 a	2.91 a	1.25 a	1.88 a	2.76 a	3.55 a	5.13 a	1.59 a	2.36 a	3.45 a	5.48 a	6.26 a	2.78 a	4.07 a	5.16 a	7.3 a
	24	0.76 d	1.28 c	2.05 b	2.78 a	1.03 c	1.66 b	2.59 a	3.41 a	4.99 a	1.33 c	2.13 a	3.27 a	5.27 a	6.11 a	2.52 a	3.86 a	4.97 a	7.13 a
14	12	0.85 c	1.31 b	1.86 a	2.43 a	1.09 b	1.63 a	2.28 a	2.93 a	4.17 a	1.38 a	2.05 a	2.82 a	4.45 a	5.08 a	2.42 a	3.33 a	4.22 a	5.95 a
	16	0.72 d	1.18 c	1.77 b	2.36 a	0.95 d	1.5 b	2.19 a	2.85 a	4.09 a	1.23 c	1.91 b	2.72 a	4.33 a	4.99 a	2.26 a	3.22 a	4.11 a	5.86 a
	24	0.47 e	0.93 e	1.59 d	2.21 c	0.69 e	1.23 d	2 c	2.68 b	3.93 a	0.93 d	1.63 d	2.52 c	4.1 a	4.83 a	1.95 c	2.99 b	3.9 a	5.66 a
16	12	0.63 d	1.01 d	1.49 c	1.96 b	0.82 d	1.28 c	1.82 b	2.35 a	3.35 a	1.05 c	1.62 b	2.25 a	3.56 a	4.09 a	1.93 a	2.66 a	3.4 a	4.82 a
	16	0.49 e	0.87 e	1.39 d	1.88 c	0.67 e	1.13 d	1.72 c	2.27 b	3.26 a	0.88 d	1.47 c	2.14 c	3.43 a	4 a	1.76 c	2.54 b	3.28 a	4.72 a
	24	0.2 f	0.59 f	1.2 e	1.72 e	0.37 f	0.84 e	1.52 e	2.09 d	3.1 c	0.55 e	1.16 e	1.92 d	3.18 c	3.83 b	1.41 d	2.29 d	3.06 c	4.51 a

Wall Height (ft)	Spacing (in.) o.c.	362S300-(mils)			600S137-(mils)					600S162-(mils)					
		50 ksi			33 ksi		50 ksi			33 ksi		50 ksi			
		54	68	97	33	43	54	68	97	33	43	54	68	97	118
8	12	5.79 a	8.01 a	11.82 a	1.77 a	2.51 a	3.8 a	5.03 a	7.52 a	2.44 a	3.4 a	5.59 a	7.42 a	11.35 a	14.19 a
	16	5.73 a	7.95 a	11.76 a	1.74 a	2.47 a	3.77 a	5 a	7.5 a	2.4 a	3.37 a	5.56 a	7.39 a	11.32 a	14.16 a
	24	5.61 a	7.83 a	11.65 a	1.67 a	2.41 a	3.71 a	4.95 a	7.45 a	2.33 a	3.3 a	5.49 a	7.33 a	11.25 a	14.09 a
9	12	5.49 a	7.51 a	11.15 a	1.75 a	2.48 a	3.77 a	5 a	7.5 a	2.4 a	3.37 a	5.57 a	7.4 a	11.32 a	14.17 a
	16	5.42 a	7.44 a	11.09 a	1.7 a	2.44 a	3.74 a	4.97 a	7.47 a	2.35 a	3.33 a	5.52 a	7.36 a	11.28 a	14.13 a
	24	5.28 a	7.29 a	10.96 a	1.61 a	2.36 a	3.67 a	4.9 a	7.41 a	2.26 a	3.24 a	5.44 a	7.28 a	11.2 a	14.04 a
10	12	5.17 a	6.99 a	10.28 a	1.71 a	2.45 a	3.75 a	4.98 a	7.48 a	2.35 a	3.32 a	5.52 a	7.37 a	11.29 a	14.14 a
	16	5.09 a	6.9 a	10.21 a	1.66 a	2.4 a	3.71 a	4.94 a	7.44 a	2.29 a	3.27 a	5.47 a	7.32 a	11.24 a	14.09 a
	24	4.92 a	6.74 a	10.06 a	1.55 a	2.3 a	3.62 a	4.86 a	7.37 a	2.18 a	3.16 a	5.37 a	7.22 a	11.14 a	13.98 a
12	12	4.55 a	5.93 a	8.45 a	1.64 a	2.38 a	3.69 a	4.93 a	7.43 a	2.23 a	3.18 a	5.29 a	7.16 a	11.23 a	14.07 a
	16	4.44 a	5.83 a	8.36 a	1.57 a	2.31 a	3.63 a	4.87 a	7.38 a	2.15 a	3.11 a	5.22 a	7.09 a	11.15 a	13.99 a
	24	4.22 a	5.62 a	8.18 a	1.41 a	2.16 a	3.51 a	4.75 a	7.27 a	1.99 a	2.96 a	5.07 a	6.96 a	11.01 a	13.84 a
14	12	3.8 a	4.85 a	6.85 a	1.56 a	2.3 a	3.63 a	4.86 a	7.37 a	2.07 a	3 a	4.96 a	6.75 a	10.8 a	13.99 a
	16	3.68 a	4.73 a	6.75 a	1.45 a	2.2 a	3.55 a	4.78 a	7.3 a	1.97 a	2.9 a	4.87 a	6.66 a	10.7 a	13.89 a
	24	3.42 a	4.5 a	6.54 a	1.24 a	2 a	3.38 a	4.62 a	7.15 a	1.76 a	2.71 a	4.68 a	6.49 a	10.51 a	13.68 a
16	12	3.07 a	3.92 a	5.58 a	1.45 a	2.2 a	3.55 a	4.79 a	7.3 a	1.89 a	2.78 a	4.54 a	6.22 a	9.94 a	12.85 a
	16	2.93 a	3.79 a	5.47 a	1.31 a	2.07 a	3.44 a	4.68 a	7.21 a	1.76 a	2.66 a	4.43 a	6.11 a	9.82 a	12.72 a
	24	2.66 c	3.54 b	5.25 a	1.04 c	1.81 a	3.23 a	4.47 a	7.02 a	1.5 b	2.41 a	4.21 a	5.89 a	9.59 a	12.48 a

Wall Height (ft)	Spacing (in.) o.c.	600S200-(mils)						600S250-(mils)						600S300-(mils)				600S350-(mils)			
		33 ksi			50 ksi			33 ksi			50 ksi			50 ksi							
		33	43	54	68	97	118	43	54	68	97	118	54	68	97	118	54	68	97	118	
8	12	2.86 a	4.29 a	7.35 a	9.77 a	15.24 a	19.54 a	4.65 a	7.59 a	10.93 a	17.91 a	22.79 a	7.9 a	11.11 a	19.22 a	24.9 a	10.21 a	14.72 a	23.85 a	31.42 a	
	16	2.82 a	4.25 a	7.31 a	9.73 a	15.2 a	19.5 a	4.61 a	7.55 a	10.88 a	17.86 a	22.75 a	7.86 a	11.07 a	19.17 a	24.85 a	10.17 a	14.68 a	23.8 a	31.36 a	
	24	2.74 a	4.17 a	7.23 a	9.65 a	15.12 a	19.42 a	4.52 a	7.48 a	10.8 a	17.77 a	22.65 a	7.78 a	10.98 a	19.08 a	24.76 a	10.09 a	14.59 a	23.7 a	31.26 a	
9	12	2.81 a	4.22 a	7.22 a	9.62 a	15.01 a	19.25 a	4.58 a	7.47 a	10.74 a	17.58 a	22.38 a	7.78 a	10.93 a	18.86 a	24.47 a	10.03 a	14.47 a	23.44 a	30.71 a	
	16	2.76 a	4.17 a	7.18 a	9.57 a	14.96 a	19.2 a	4.53 a	7.42 a	10.69 a	17.52 a	22.32 a	7.73 a	10.88 a	18.81 a	24.41 a	9.98 a	14.42 a	23.38 a	30.64 a	
	24	2.66 a	4.06 a	7.08 a	9.47 a	14.87 a	19.1 a	4.42 a	7.33 a	10.58 a	17.41 a	22.21 a	7.63 a	10.77 a	18.69 a	24.29 a	9.87 a	14.31 a	23.25 a	30.52 a	
10	12	2.75 a	4.14 a	7.07 a	9.43 a	14.73 a	18.9 a	4.5 a	7.33 a	10.53 a	17.2 a	21.89 a	7.63 a	10.72 a	18.45 a	23.97 a	9.82 a	14.19 a	22.97 a	29.9 a	
	16	2.69 a	4.07 a	7.01 a	9.37 a	14.67 a	18.83 a	4.44 a	7.27 a	10.46 a	17.13 a	21.82 a	7.57 a	10.66 a	18.38 a	23.89 a	9.75 a	14.12 a	22.9 a	29.82 a	
	24	2.57 a	3.95 a	6.89 a	9.25 a	14.56 a	18.71 a	4.31 a	7.15 a	10.33 a	16.99 a	21.68 a	7.45 a	10.53 a	18.24 a	23.75 a	9.63 a	13.98 a	22.75 a	29.67 a	
12	12	2.61 a	3.94 a	6.69 a	8.94 a	14 a	17.95 a	4.31 a	6.98 a	10.01 a	16.23 a	20.67 a	7.27 a	10.27 a	17.45 a	22.79 a	9.32 a	13.52 a	21.92 a	28.01 a	
	16	2.53 a	3.85 a	6.6 a	8.86 a	13.92 a	17.87 a	4.22 a	6.9 a	9.92 a	16.14 a	20.57 a	7.19 a	10.19 a	17.36 a	22.69 a	9.24 a	13.42 a	21.82 a	27.9 a	
	24	2.36 a	3.67 a	6.44 a	8.69 a	13.76 a	17.7 a	4.03 a	6.74 a	9.74 a	15.94 a	20.37 a	7.02 a	10.01 a	17.17 a	22.49 a	9.06 a	13.23 a	21.61 a	27.7 a	
14	12	2.44 a	3.68 a	6.19 a	8.3 a	13.04 a	16.69 a	4.08 a	6.6 a	9.38 a	15.04 a	19.14 a	6.84 a	9.74 a	16.28 a	21.48 a	8.75 a	12.73 a	20.52 a	25.83 a	
	16	2.32 a	3.57 a	6.08 a	8.19 a	12.94 a	16.59 a	3.95 a	6.49 a	9.27 a	14.92 a	19.01 a	6.73 a	9.63 a	16.16 a	21.35 a	8.63 a	12.6 a	20.38 a	25.7 a	
	24	2.1 a	3.34 a	5.87 a	7.98 a	12.73 a	16.37 a	3.71 a	6.28 a	9.03 a	14.67 a	18.76 a	6.51 a	9.39 a	15.92 a	21.09 a	8.41 a	12.36 a	20.12 a	25.44 a	
16	12	2.23 a	3.38 a	5.6 a	7.55 a	11.89 a	15.19 a	3.8 a	6.21 a	8.7 a	13.68 a	17.4 a	6.34 a	9.14 a	15.01 a	19.59 a	8.1 a	11.84 a	18.64 a	23.47 a	
	16	2.09 a	3.24 a	5.47 a	7.42 a	11.76 a	15.06 a	3.65 a	6.08 a	8.56 a	13.54 a	17.25 a	6.21 a	8.99 a	14.87 a	19.44 a	7.96 a	11.69 a	18.48 a	23.31 a	
	24	1.81 a	2.96 a	5.22 a	7.16 a	11.52 a	14.81 a	3.35 a	5.81 a	8.28 a											

## 5 psf Lateral Load (Interior Walls Only)

Wall Height (ft)	Spacing (in.) o.c.	800S137-(mils)					800S162-(mils)					800S200-(mils)						
		33 ksi		50 ksi			33 ksi		50 ksi			33 ksi		50 ksi				
		33	43	54	68	97	33	43	54	68	97	118	33	43	54	68	97	118
8	12	1.7 a*	2.43 a	3.56 a	4.73 a	7.23 a	2.38 a*	3.35 a	5.42 a	7.23 a	11.25 a	14.31 a	2.95 a*	4.49 a	7.74 a	10.27 a	15.96 a	20.43 a
	16	1.67 a*	2.4 a	3.54 a	4.72 a	7.21 a	2.35 a*	3.33 a	5.4 a	7.21 a	11.23 a	14.29 a	2.92 a*	4.46 a	7.72 a	10.24 a	15.93 a	20.41 a
	24	1.62 a*	2.36 a	3.5 a	4.68 a	7.18 a	2.28 a*	3.27 a	5.35 a	7.16 a	11.18 a	14.24 a	2.84 a*	4.4 a	7.66 a	10.19 a	15.88 a	20.35 a
9	12	1.68 a*	2.41 a	3.54 a	4.72 a	7.22 a	2.35 a*	3.33 a	5.4 a	7.21 a	11.23 a	14.29 a	2.92 a*	4.46 a	7.72 a	10.25 a	15.93 a	20.41 a
	16	1.64 a*	2.38 a	3.52 a	4.7 a	7.2 a	2.31 a*	3.3 a	5.37 a	7.18 a	11.2 a	14.26 a	2.88 a*	4.43 a	7.69 a	10.21 a	15.9 a	20.38 a
	24	1.57 a*	2.32 a	3.47 a	4.65 a	7.16 a	2.22 a*	3.23 a	5.31 a	7.12 a	11.15 a	14.21 a	2.78 a*	4.35 a	7.61 a	10.14 a	15.83 a	20.31 a
10	12	1.65 a*	2.39 a	3.53 a	4.7 a	7.2 a	2.32 a*	3.31 a	5.38 a	7.19 a	11.21 a	14.27 a	2.89 a*	4.44 a	7.7 a	10.22 a	15.91 a	20.39 a
	16	1.61 a*	2.35 a	3.5 a	4.68 a	7.18 a	2.27 a*	3.26 a	5.34 a	7.15 a	11.18 a	14.24 a	2.83 a*	4.39 a	7.65 a	10.18 a	15.87 a	20.34 a
	24	1.52 a*	2.28 a	3.44 a	4.62 a	7.13 a	2.16 a*	3.18 a	5.27 a	7.08 a	11.11 a	14.17 a	2.71 a*	4.3 a	7.56 a	10.09 a	15.79 a	20.26 a
12	12	1.59 a*	2.34 a	3.49 a	4.67 a	7.17 a	2.25 a*	3.25 a	5.33 a	7.14 a	11.17 a	14.23 a	2.8 a*	4.37 a	7.63 a	10.17 a	15.86 a	20.33 a
	16	1.53 a*	2.29 a	3.45 a	4.63 a	7.13 a	2.17 a*	3.19 a	5.28 a	7.09 a	11.12 a	14.18 a	2.72 a*	4.3 a	7.57 a	10.1 a	15.8 a	20.27 a
	24	1.4 a*	2.18 a	3.37 a	4.55 a	7.06 a	2.02 a*	3.06 a	5.17 a	6.98 a	11.02 a	14.08 a	2.55 a*	4.17 a	7.44 a	9.98 a	15.68 a	20.14 a
14	12	1.52 a*	2.28 a	3.44 a	4.62 a	7.13 a	2.17 a*	3.18 a	5.27 a	7.08 a	11.11 a	14.17 a	2.68 a*	4.23 a	7.39 a	9.91 a	15.7 a	20.26 a
	16	1.44 a*	2.21 a	3.39 a	4.57 a	7.08 a	2.06 a*	3.1 a	5.2 a	7.01 a	11.04 a	14.11 a	2.57 a*	4.14 a	7.3 a	9.83 a	15.62 a	20.18 a
	24	1.26 a*	2.07 a	3.28 a	4.46 a	6.98 a	1.85 a*	2.93 a	5.05 a	6.87 a	10.91 a	13.97 a	2.34 a*	3.97 a	7.14 a	9.66 a	15.46 a	20.01 a
16	12	1.44 a*	2.22 a	3.39 a	4.57 a	7.09 a	2.07 a*	3.1 a	5.2 a	7.02 a	11.05 a	14.11 a	2.53 a*	4.05 a	7.05 a	9.49 a	15.09 a	19.6 a
	16	1.33 a*	2.13 a	3.32 a	4.5 a	7.02 a	1.93 a*	2.99 a	5.11 a	6.92 a	10.96 a	14.02 a	2.38 a*	3.94 a	6.95 a	9.39 a	14.99 a	19.49 a
	24	1.1 a*	1.94 a	3.17 a	4.36 a	6.9 a	1.65 a*	2.77 a	4.91 a	6.73 a	10.79 a	13.85 a	2.09 a*	3.72 a	6.73 a	9.18 a	14.78 a	19.28 a

Wall Height (ft)	Spacing (in.) o.c.	800S250-(mils)				800S300-(mils)				800S350-(mils)				
		33 ksi		50 ksi		50 ksi		50 ksi		50 ksi		50 ksi		
		43	54	68	97	118	54	68	97	118	54	68	97	118
8	12	4.89 a	8.13 a	11.73 a	19.55 a	25.43 a	8.48 a	12 a	21.32 a	27.8 a	10.93 a	15.73 a	25.86 a	34.32 a
	16	4.86 a	8.1 a	11.7 a	19.52 a	25.4 a	8.45 a	11.97 a	21.28 a	27.76 a	10.9 a	15.7 a	25.83 a	34.28 a
	24	4.8 a	8.04 a	11.64 a	19.45 a	25.33 a	8.39 a	11.91 a	21.21 a	27.69 a	10.84 a	15.64 a	25.75 a	34.2 a
9	12	4.85 a	8.07 a	11.67 a	19.45 a	25.26 a	8.41 a	11.92 a	21.14 a	27.58 a	10.83 a	15.61 a	25.7 a	34.05 a
	16	4.82 a	8.03 a	11.63 a	19.4 a	25.22 a	8.37 a	11.88 a	21.1 a	27.54 a	10.79 a	15.57 a	25.65 a	34 a
	24	4.74 a	7.96 a	11.55 a	19.32 a	25.13 a	8.3 a	11.8 a	21.01 a	27.45 a	10.71 a	15.48 a	25.56 a	33.91 a
10	12	4.81 a	8 a	11.59 a	19.32 a	25.05 a	8.33 a	11.81 a	20.93 a	27.32 a	10.71 a	15.46 a	25.46 a	33.74 a
	16	4.76 a	7.96 a	11.54 a	19.27 a	25 a	8.28 a	11.76 a	20.88 a	27.27 a	10.66 a	15.41 a	25.4 a	33.68 a
	24	4.66 a	7.86 a	11.45 a	19.16 a	24.89 a	8.19 a	11.67 a	20.77 a	27.16 a	10.56 a	15.31 a	25.29 a	33.57 a
12	12	4.7 a	7.82 a	11.38 a	18.99 a	24.47 a	8.13 a	11.53 a	20.37 a	26.64 a	10.41 a	15.09 a	24.78 a	32.99 a
	16	4.63 a	7.76 a	11.32 a	18.92 a	24.39 a	8.06 a	11.47 a	20.3 a	26.56 a	10.34 a	15.02 a	24.7 a	32.91 a
	24	4.49 a	7.63 a	11.18 a	18.77 a	24.24 a	7.92 a	11.33 a	20.14 a	26.4 a	10.2 a	14.87 a	24.54 a	32.74 a
14	12	4.56 a	7.58 a	11.02 a	18.34 a	23.64 a	7.86 a	11.17 a	19.63 a	25.73 a	10.04 a	14.6 a	23.95 a	31.77 a
	16	4.46 a	7.49 a	10.93 a	18.24 a	23.54 a	7.77 a	11.08 a	19.53 a	25.63 a	9.95 a	14.51 a	23.84 a	31.66 a
	24	4.28 a	7.32 a	10.75 a	18.05 a	23.33 a	7.59 a	10.91 a	19.33 a	25.42 a	9.77 a	14.32 a	23.63 a	31.44 a
16	12	4.38 a	7.26 a	10.54 a	17.48 a	22.56 a	7.53 a	10.72 a	18.72 a	24.64 a	9.61 a	14.03 a	23.01 a	30.13 a
	16	4.26 a	7.15 a	10.43 a	17.36 a	22.43 a	7.42 a	10.61 a	18.6 a	24.51 a	9.5 a	13.91 a	22.88 a	30 a
	24	4.03 a	6.94 a	10.2 a	17.11 a	22.17 a	7.19 a	10.39 a	18.35 a	24.25 a	9.26 a	13.67 a	22.61 a	29.73 a

See Combined Axial and Lateral Load Table Notes

## 15 psf Lateral Load

Wall Height (ft)	Spacing (in.) o.c.	362S137-(mils)				362S162-(mils)					362S200-(mils)				362S250-(mils)				
		33 ksi		50 ksi		33 ksi		50 ksi			33 ksi		50 ksi		33 ksi		50 ksi		
		33	43	54	68	33	43	54	68	97	97	33	54	68	97	33	54	68	97
8	12	1.13 a	1.75 a	2.85 a	3.82 a	1.5 a	2.18 a	3.69 a	4.85 a	7.21 a	1.87 a	2.88 a	4.72 a	7.6 a	8.92 a	3.3 a	5.37 a	7.17 a	10.24 a
	16	0.96 a	1.58 a	2.71 a	3.7 a	1.32 a	2 a	3.54 a	4.72 a	7.08 a	1.67 a	2.69 a	4.55 a	7.4 a	8.78 a	3.09 a	5.19 a	6.99 a	10.08 a
	24	0.63 b	1.25 a	2.45 a	3.47 a	0.96 a	1.66 a	3.25 a	4.45 a	6.82 a	1.27 a	2.3 a	4.22 a	7.01 a	8.5 a	2.68 a	4.83 a	6.64 a	9.76 a
9	12	0.97 a	1.57 a	2.61 a	3.54 a	1.31 a	1.96 a	3.39 a	4.47 a	6.66 a	1.65 a	2.62 a	4.32 a	7.01 a	8.21 a	3.05 a	5 a	6.58 a	9.45 a
	16	0.77 a	1.37 a	2.45 a	3.4 a	1.09 a	1.75 a	3.21 a	4.31 a	6.5 a	1.41 a	2.39 a	4.12 a	6.78 a	8.05 a	2.79 a	4.78 a	6.37 a	9.26 a
	24	0.36 c	0.96 b	2.13 a	3.12 a	0.65 c	1.33 a	2.86 a	4 a	6.19 a	0.93 b	1.92 a	3.72 a	6.32 a	7.72 a	2.28 a	4.35 a	5.95 a	8.87 a
10	12	0.8 b	1.38 a	2.35 a	3.23 a	1.11 a	1.63 a	3.06 a	4.06 a	6.05 a	1.43 a	2.35 a	3.89 a	6.35 a	7.45 a	2.77 a	4.59 a	5.96 a	8.61 a
	16	0.56 c	1.13 b	2.17 a	3.07 a	0.85 b	1.4 a	2.86 a	3.88 a	5.87 a	1.14 a	2.07 a	3.67 a	6.08 a	7.27 a	2.47 a	4.33 a	5.72 a	8.39 a
	24	0.07 e	0.65 d	1.79 c	2.74 b	0.33 d	0.93 c	2.45 b	3.52 a	5.51 a	0.56 c	1.52 b	3.21 a	5.55 a	6.89 a	1.86 a	3.82 a	5.24 a	7.95 a
12	12	0.44 d	0.96 c	1.82 b	2.58 a	0.69 d	1.32 b	2.35 a	3.19 a	4.78 a	0.95 c	1.77 a	2.99 a	4.95 a	5.89 a	2.13 a	3.55 a	4.68 a	6.87 a
	16	0.12 e	0.64 d	1.59 c	2.38 b	0.35 e	0.99 d	2.1 c	2.98 b	4.57 a	0.57 d	1.42 c	2.72 b	4.63 a	5.67 a	1.73 b	3.25 a	4.4 a	6.61 a
	24			1.13 e	1.98 d		0.32 e	1.61 d	2.54 d	4.14 b	-0.18 e	0.7 d	2.17 d	4 c	5.23 a	0.94 d	2.63 c	3.82 b	6.09 a
14	12	0.08 e	0.54 e	1.33 d	1.98 c	0.28 e	0.84 d	1.73 d	2.44 c	3.7 a	0.47 e	1.2 d	2.21 c	3.75 b	4.59 a	1.48 c	2.64 b	3.58 a	5.37 a
	16		0.16 e	1.06 e	1.75 d		0.44 e	1.45 e	2.2 d	3.46 c	0.02 e	0.78 e	1.9 d	3.4 c	4.34 b	1.01 d	2.3 c	3.26 b	5.08 a
	24			0.53 f	1.3 e			0.9 f	1.71 e	3 d			1.29 e	2.7 e	3.86 d	0.08 e	1.61 e	2.63 d	4.51 c
16	12		0.16 f	0.91 e	1.47 e		0.4 e	1.22 e	1.83 d	2.85 c	0.05 f	0.69 e	1.59 d	2.81 d	3.57 b	0.89 e	1.92 d	2.71 c	4.2 a
	16			0.61 f	1.22 e			0.92 f	1.57 e	2.6 d			0.23 f	1.26 e	2.43 e	0.37 e	1.55 e	2.37 d	3.89 c
	24			0.03 f	0.73 f			0.32 f	1.04 f	2.09 e			0.6 f	1.69 f	2.79 e		0.81 f	1.68 e	3.27 d

Wall Height (ft)	Spacing (in.) o.c.	362S300-(mils)			600S137-(mils)				600S162-(mils)					600S200-(mils)			
		50 ksi			33 ksi		50 ksi		33 ksi		50 ksi			33 ksi			
		54	68	97	33	43	54	68	97	33	43	54	68	97	118	33	43
8	12	5.26 a	7.47 a	11.32 a	1.46 a	2.21 a	3.55 a	4.79 a	7.3 a	2.11 a	3.09 a	5.3 a	7.14 a	11.06 a	13.89 a	2.51 a	3.92 a
	16	5.02 a	7.22 a	11.1 a	1.33 a	2.08 a	3.44 a	4.68 a	7.21 a	1.97 a	2.96 a	5.16 a	7.01 a	10.93 a	13.76 a	2.35 a	3.75 a
	24	4.55 a	6.74 a	10.66 a	1.05 a	1.81 a	3.23 a	4.47 a	7.02 a	1.68 a	2.68 a	4.9 a	6.76 a	10.67 a	13.49 a	2.03 a	3.42 a
9	12	4.85 a	6.86 a	10.56 a	1.35 a	2.1 a	3.47 a	4.7 a	7.23 a	1.99 a	2.98 a	5.19 a	7.04 a	10.95 a	13.79 a	2.36 a	3.75 a
	16	4.57 a	6.57 a	10.29 a	1.18 a	1.93 a	3.33 a	4.57 a	7.11 a	1.81 a	2.81 a	5.02 a	6.88 a	10.79 a	13.62 a	2.17 a	3.55 a
	24	3.99 a	6 a	9.77 a	0.83 a	1.6 a	3.05 a	4.3 a	6.86 a	1.45 a	2.46 a	4.69 a	6.56 a	10.46 a	13.28 a	1.77 a	3.14 a
10	12	4.42 a	6.24 a	9.6 a	1.23 a	1.98 a	3.37 a	4.61 a	7.14 a	1.85 a	2.84 a	5.06 a	6.93 a	10.84 a	13.67 a	2.21 a	3.57 a
	16	4.08 a	5.9 a	9.3 a	1.02 a	1.78 a	3.2 a	4.44 a	6.99 a	1.63 a	2.63 a	4.85 a	6.73 a	10.64 a	13.46 a	1.96 a	3.32 a
	24	3.41 a	5.24 a	8.7 a	0.59 a	1.36 a	2.86 a	4.11 a	6.69 a	1.18 a	2.2 a	4.44 a	6.34 a	10.23 a	13.04 a	1.48 a	2.81 a
12	12	3.57 a	5 a	7.64 a	0.95 a	1.71 a	3.15 a	4.39 a	6.94 a	1.52 a	2.51 a	4.64 a	6.54 a	10.57 a	13.39 a	1.84 a	3.14 a
	16	3.14 b	4.59 a	7.27 a	0.64 a	1.41 a	2.9 a	4.15 a	6.73 a	1.21 a	2.2 a	4.35 a	6.26 a	10.28 a	13.09 a	1.5 a	2.79 a
	24	2.27 d	3.76 c	6.55 a	0.02 c	0.81 b	2.41 a	3.67 a	6.29 a	0.58 c	1.6 a	3.78 a	5.71 a	9.69 a	12.49 a	0.81 b	2.09 a
14	12	2.66 c	3.79 b	5.94 a	0.61 b	1.39 a	2.88 a	4.13 a	6.71 a	1.15 a	2.11 a	4.13 a	5.95 a	9.93 a	13.07 a	1.42 a	2.65 a
	16	2.16 d	3.32 c	5.54 b	0.19 d	0.98 b	2.55 a	3.8 a	6.41 a	0.73 c	1.71 b	3.75 a	5.59 a	9.54 a	12.66 a	0.97 b	2.19 a
	24	1.14 e	2.39 e	4.73 d		0.17 d	1.89 c	3.15 b	5.82 a	-0.09 d	0.92 d	3.01 c	4.87 a	8.77 a	11.84 a	0.07 d	1.27 c
16	12	1.83 e	2.78 d	4.6 b	0.22 d	1.01 c	2.58 b	3.83 a	6.44 a	0.73 c	1.67 b	3.53 a	5.23 a	8.89 a	11.74 a	0.96 c	2.1 a
	16	1.28 e	2.27 e	4.16 d	-0.32 e	0.48 d	2.14 c	3.4 b	6.05 a	0.22 d	1.17 d	3.07 c	4.8 a	8.42 a	11.24 a	0.4 d	1.54 c
	24	0.18 f	1.26 f	3.29 e	0	0.58 e	1.28 e	2.55 d	5.28 c		0.18 e	2.17 d	3.92 c	7.49 b	10.26 a	-0.73 e	0.4 d

Wall Height (ft)	Spacing (in.) o.c.	600S200-(mils)				600S250-(mils)				600S300-(mils)				600S350-(mils)				
		50 ksi				33 ksi		50 ksi		33 ksi		50 ksi		33 ksi		50 ksi		
		54	68	97	118	33	43	54	68	97	118	54	68	97	118	54	68	97
8	12	7.11 a	9.54 a	15.01 a	19.3 a	4.39 a	7.36 a	10.67 a	17.63 a	22.51 a	7.67 a	10.85 a	18.94 a	24.61 a	9.96 a	14.45 a	23.56 a	31.11 a
	16	6.99 a	9.42 a	14.89 a	19.18 a	4.27 a	7.24 a	10.54 a	17.49 a	22.36 a	7.55 a	10.73 a	18.8 a	24.47 a	9.83 a	14.32 a	23.41 a	30.95 a
	24	6.76 a	9.18 a	14.66 a	18.94 a	4.01 a	7.01 a	10.28 a	17.21 a	22.07 a	7.31 a	10.48 a	18.53 a	24.18 a	9.58 a	14.04 a	23.11 a	30.65 a
9	12	6.93 a	9.32 a	14.72 a	18.95 a	4.26 a	7.18 a	10.42 a	17.23 a	22.03 a	7.48 a	10.61 a	18.52 a	24.11 a	9.71 a	14.14 a	23.07 a	30.33 a
	16	6.78 a	9.17 a	14.58 a	18.8 a	4.1 a	7.03 a	10.26 a	17.06 a	21.85 a	7.33 a	10.46 a	18.35 a	23.93 a	9.56 a	13.97 a	22.88 a	30.13 a
	24	6.48 a	8.87 a	14.29 a	18.5 a	3.78 a	6.74 a	9.94 a	16.71 a	21.49 a	7.04 a	10.14 a	18 a	23.57 a	9.24 a	13.63 a	22.51 a	29.75 a
10	12	6.71 a	9.07 a	14.38 a	18.53 a	4.11 a	6.98 a	10.14 a	16.77 a	21.46 a	7.27 a	10.34 a	18.03 a	23.53 a	9.44 a	13.78 a	22.52 a	29.44 a
	16	6.53 a	8.89 a	14.21 a	18.35 a	3.91 a	6.8 a	9.94 a	16.56 a	21.24 a	7.09 a	10.15 a	17.82 a	23.31 a	9.25 a	13.57 a	22.3 a	29.21 a
	24	6.17 a	8.52 a	13.86 a	17.98 a	3.52 a	6.44 a	9.55 a	16.14 a	20.81 a	6.73 a	9.76 a	17.4 a	22.88 a	8.87 a	13.16 a	21.85 a	28.75 a
12	12	6.19 a	8.44 a	13.52 a	17.45 a	3.76 a	6.49 a	9.47 a	15.66 a	20.07 a	6.77 a	9.74 a	16.88 a	22.19 a	8.8 a	12.95 a	21.3 a	27.39 a
	16	5.94 a	8.19 a	13.29 a	17.2 a	3.48 a	6.24 a	9.2 a	15.37 a	19.78 a	6.52 a	9.47 a	16.6 a	21.89 a	8.54 a	12.67 a	20.99 a	27.08 a
	24	5.44 a	7.69 a	12.81 a	16.69 a	2.93 a	5.75 a	8.66 a	14.79 a	19.18 a	6.02 a	8.94 a	16.02 a	21.3 a	8.01 a	12.1 a	20.37 a	26.46 a
14	12	5.55 a	7.66 a	12.43 a	16.05 a	3.35 a	5.95 a	8.69 a	14.31 a	18.39 a	6.19 a	9.05 a	15.55 a	20.71 a	8.07 a	11.99 a	19.72 a	25.05 a
	16	5.24 a	7.35 a	12.12 a	15.73 a	2.99 a	5.63 a	8.34 a	13.94 a	18.01 a	5.86 a	8.7 a	15.19 a	20.32 a	7.73 a	11.63 a	19.32 a	24.66 a
	24	4.6 a	6.71 a	11.51 a	15.09 a	2.26 a	4.99 a	7.64 a	13.21 a	17.26 a	5.22 a	8 a	14.46 a	19.55 a	7.05 a	10.89 a	18.53 a	23.88 a
16	12	4.84 a	6.78 a	11.15 a	14.42 a	2.89 a	5.41 a	7.85 a	12.81 a	16.5 a	5.55 a	8.28 a	14.13 a	18.67 a	7.27 a	10.94 a	17.69 a	22.54 a
	16	4.46 a	6.4 a	10.79 a	14.04 a	2.44 a	5 a	7.42 a	12.37 a	16.05 a	5.15 a	7.85 a	13.68 a	18.21 a	6.86 a	10.49 a	17.22 a	22.07 a
	24	3.7 b	5.64 a	10.06 a	13.27 a	1.53 c	4.2 b	6.57 a	11.49 a	15.15 a	4.35 a	6.99 a	12.8 a	17.29 a	6.03 a	9.59 a	16.27 a	21.14 a

## 15 psf Lateral Load

Wall Height (ft)	Spacing (in.) o.c.	800S137-(mils)					800S162-(mils)					800S200-(mils)						
		33 ksi		50 ksi			33 ksi		50 ksi			33 ksi		50 ksi				
		33	43	54	68	97	33	43	54	68	97	118	33	43	54	68	97	118
8	12	1.53 a*	2.29 a	3.45 a	4.63 a	7.13 a	2.17 a*	3.19 a	5.28 a	7.09 a	11.12 a	14.18 a	2.73 a*	4.31 a	7.58 a	10.1 a	15.8 a	20.27 a
	16	1.44 a*	2.22 a	3.39 a	4.57 a	7.09 a	2.07 a*	3.1 a	5.2 a	7.02 a	11.05 a	14.11 a	2.62 a*	4.23 a	7.49 a	10.02 a	15.72 a	20.18 a
	24	1.27 a*	2.08 a	3.28 a	4.47 a	6.99 a	1.86 a*	2.94 a	5.06 a	6.88 a	10.92 a	13.98 a	2.39 a*	4.06 a	7.32 a	9.85 a	15.56 a	20.02 a
9	12	1.46 a*	2.23 a	3.4 a	4.58 a	7.1 a	2.09 a*	3.12 a	5.22 a	7.03 a	11.06 a	14.13 a	2.64 a*	4.25 a	7.51 a	10.04 a	15.73 a	20.2 a
	16	1.35 a*	2.15 a	3.34 a	4.52 a	7.04 a	1.96 a*	3.01 a	5.13 a	6.94 a	10.98 a	14.04 a	2.5 a*	4.14 a	7.4 a	9.93 a	15.63 a	20.09 a
	24	1.14 a*	1.97 a	3.2 a	4.38 a	6.91 a	1.69 a*	2.8 a	4.94 a	6.76 a	10.81 a	13.88 a	2.21 a*	3.92 a	7.19 a	9.72 a	15.43 a	19.88 a
10	12	1.38 a*	2.17 a	3.36 a	4.54 a	7.05 a	2 a*	3.05 a	5.15 a	6.97 a	11.01 a	14.07 a	2.54 a*	4.17 a	7.43 a	9.96 a	15.66 a	20.13 a
	16	1.25 a*	2.06 a	3.27 a	4.46 a	6.98 a	1.83 a*	2.92 a	5.04 a	6.86 a	10.9 a	13.96 a	2.36 a*	4.03 a	7.3 a	9.83 a	15.54 a	20 a
	24	0.98 a*	1.85 a	3.1 a	4.29 a	6.83 a	1.51 a*	2.66 a	4.81 a	6.64 a	10.7 a	13.76 a	2.01 a*	3.76 a	7.04 a	9.57 a	15.29 a	19.73 a
12	12	1.21 a*	2.03 a	3.24 a	4.43 a	6.96 a	1.78 a*	2.87 a	5 a	6.82 a	10.87 a	13.93 a	2.3 a*	3.98 a	7.25 a	9.79 a	15.5 a	19.95 a
	16	1.02 a*	1.87 a	3.12 a	4.31 a	6.85 a	1.55 a*	2.69 a	4.84 a	6.66 a	10.72 a	13.78 a	2.05 a*	3.79 a	7.06 a	9.6 a	15.32 a	19.76 a
	24	0.63 a*	1.56 a	2.87 a	4.07 a	6.63 a	1.08 a*	2.31 a	4.51 a	6.34 a	10.43 a	13.49 a	1.54 a*	3.4 a	6.68 a	9.23 a	14.96 a	19.39 a
14	12	1 a*	1.86 a	3.11 a	4.3 a	6.84 a	1.53 a*	2.67 a	4.82 a	6.65 a	10.71 a	13.77 a	2 a*	3.71 a	6.88 a	9.41 a	15.21 a	19.75 a
	16	0.74 a*	1.65 a	2.94 a	4.14 a	6.69 a	1.21 a*	2.42 a	4.6 a	6.43 a	10.51 a	13.57 a	1.66 a*	3.45 a	6.63 a	9.16 a	14.97 a	19.49 a
	24	0.21 a*	1.22 a	2.61 a	3.81 a	6.4 a	0.57 a*	1.9 a	4.15 a	6 a	10.11 a	13.17 a	0.98 a*	2.93 a	6.12 a	8.66 a	14.48 a	18.98 a
16	12	0.76 a*	1.67 a	2.96 a	4.15 a	6.7 a	1.23 a*	2.44 a	4.62 a	6.45 a	10.53 a	13.59 a	1.66 a*	3.39 a	6.42 a	8.86 a	14.48 a	18.95 a
	16	0.42 a*	1.39 a	2.74 a	3.94 a	6.51 a	0.82 a*	2.1 a	4.33 a	6.17 a	10.26 a	13.32 a	1.22 a*	3.06 a	6.1 a	8.54 a	14.17 a	18.63 a
	24		0.84 a	2.3 a	3.52 a	6.13 a		1.44 a	3.74 a	5.6 a	9.74 a	12.8 a	0.35 a*	2.4 a	5.46 a	7.91 a	13.56 a	17.98 a

Wall Height (ft)	Spacing (in.) o.c.	800S250-(mils)					800S300-(mils)				800S350-(mils)			
		33 ksi		50 ksi			50 ksi				50 ksi			
		43	54	68	97	118	54	68	97	118	54	68	97	118
8	12	4.71 a	7.95 a	11.55 a	19.35 a	25.22 a	8.3 a	11.82 a	21.11 a	27.58 a	10.74 a	15.54 a	25.64 a	34.09 a
	16	4.61 a	7.86 a	11.46 a	19.24 a	25.11 a	8.2 a	11.73 a	21.01 a	27.47 a	10.64 a	15.44 a	25.53 a	33.97 a
	24	4.43 a	7.69 a	11.27 a	19.04 a	24.89 a	8.02 a	11.55 a	20.8 a	27.25 a	10.45 a	15.24 a	25.31 a	33.74 a
9	12	4.62 a	7.85 a	11.44 a	19.19 a	24.99 a	8.18 a	11.69 a	20.88 a	27.31 a	10.59 a	15.36 a	25.42 a	33.76 a
	16	4.5 a	7.74 a	11.32 a	19.06 a	24.86 a	8.06 a	11.57 a	20.75 a	27.17 a	10.47 a	15.24 a	25.28 a	33.62 a
	24	4.26 a	7.51 a	11.08 a	18.8 a	24.58 a	7.83 a	11.34 a	20.49 a	26.9 a	10.22 a	14.99 a	25 a	33.33 a
10	12	4.52 a	7.73 a	11.3 a	19 a	24.72 a	8.05 a	11.53 a	20.61 a	26.99 a	10.41 a	15.16 a	25.12 a	33.39 a
	16	4.37 a	7.59 a	11.16 a	18.84 a	24.55 a	7.9 a	11.39 a	20.45 a	26.82 a	10.26 a	15 a	24.95 a	33.21 a
	24	4.08 a	7.32 a	10.87 a	18.53 a	24.22 a	7.62 a	11.11 a	20.13 a	26.48 a	9.97 a	14.7 a	24.61 a	32.86 a
12	12	4.28 a	7.43 a	10.98 a	18.54 a	24 a	7.72 a	11.14 a	19.92 a	26.17 a	9.99 a	14.66 a	24.3 a	32.49 a
	16	4.08 a	7.24 a	10.77 a	18.31 a	23.77 a	7.52 a	10.94 a	19.69 a	25.93 a	9.78 a	14.45 a	24.06 a	32.24 a
	24	3.66 a	6.85 a	10.36 a	17.86 a	23.3 a	7.12 a	10.54 a	19.24 a	25.46 a	9.37 a	14.02 a	23.58 a	31.74 a
14	12	4 a	7.06 a	10.48 a	17.75 a	23.02 a	7.32 a	10.64 a	19.03 a	25.11 a	9.49 a	14.04 a	23.32 a	31.11 a
	16	3.72 a	6.8 a	10.2 a	17.45 a	22.71 a	7.05 a	10.38 a	18.74 a	24.8 a	9.21 a	13.75 a	23 a	30.78 a
	24	3.17 a	6.28 a	9.66 a	16.85 a	22.09 a	6.52 a	9.85 a	18.14 a	24.17 a	8.66 a	13.19 a	22.37 a	30.13 a
16	12	3.67 a	6.61 a	9.86 a	16.74 a	21.78 a	6.85 a	10.05 a	17.98 a	23.86 a	8.92 a	13.31 a	22.21 a	29.32 a
	16	3.31 a	6.28 a	9.52 a	16.36 a	21.39 a	6.51 a	9.72 a	17.61 a	23.47 a	8.57 a	12.95 a	21.82 a	28.91 a
	24	2.6 a	5.63 a	8.83 a	15.62 a	20.61 a	5.83 a	9.05 a	16.86 a	22.68 a	7.87 a	12.24 a	21.02 a	28.1 a

See Combined Axial and Lateral Load Table Notes

## 20 psf Lateral Load

Wall Height (ft)	Spacing (in.) o.c.	362S137-(mils)				362S162-(mils)					362S200-(mils)				362S250-(mils)				
		33 ksi		50 ksi		33 ksi		50 ksi			33 ksi		50 ksi		33 ksi		50 ksi		
		33	43	54	68	33	43	54	68	97	97	33	54	68	97	43	54	68	97
8	12	0.96 a	1.58 a	2.71 a	3.7 a	1.32 a	2 a	3.54 a	4.72 a	7.08 a	1.67 a	2.69 a	4.55 a	7.4 a	8.78 a	3.09 a	5.19 a	6.99 a	10.08 a
	16	0.74 a	1.36 a	2.54 a	3.55 a	1.08 a	1.77 a	3.35 a	4.54 a	6.9 a	1.4 a	2.43 a	4.33 a	7.14 a	8.6 a	2.82 a	4.95 a	6.76 a	9.86 a
	24	0.31 c	0.92 b	2.18 a	3.24 a	0.6 b	1.31 a	2.96 a	4.19 a	6.55 a	0.87 b	1.92 a	3.88 a	6.62 a	8.22 a	2.26 a	4.47 a	6.29 a	9.43 a
9	12	0.77 a	1.37 a	2.45 a	3.4 a	1.09 a	1.75 a	3.21 a	4.31 a	6.5 a	1.41 a	2.39 a	4.12 a	6.78 a	8.05 a	2.79 a	4.78 a	6.37 a	9.26 a
	16	0.5 c	1.09 b	2.24 a	3.22 a	0.8 b	1.47 a	2.98 a	4.1 a	6.29 a	1.09 a	2.07 a	3.85 a	6.47 a	7.83 a	2.45 a	4.49 a	6.09 a	9 a
	24		0.55 d	1.81 c	2.84 b	0.21 d	0.91 c	2.51 b	3.69 a	5.87 a	0.44 c	1.45 b	3.32 a	5.85 a	7.39 a	1.77 a	3.91 a	5.53 a	8.49 a
10	12	0.56 c	1.13 b	2.17 a	3.07 a	0.85 b	1.4 a	2.86 a	3.88 a	5.87 a	1.14 a	2.07 a	3.67 a	6.08 a	7.27 a	2.47 a	4.33 a	5.72 a	8.39 a
	16	0.24 d	0.81 c	1.92 b	2.85 a	0.5 d	1.09 c	2.59 a	3.64 a	5.63 a	0.75 c	1.7 b	3.36 a	5.73 a	7.02 a	2.06 a	3.99 a	5.4 a	8.1 a
	24		0.16 e	1.42 d	2.42 c		0.47 d	2.05 c	3.16 b	5.15 a		0.96 d	2.75 c	5.02 b	6.52 a	1.25 c	3.31 b	4.76 a	7.51 a
12	12	0.12 e	0.64 d	1.59 c	2.38 b	0.35 e	0.99 d	2.1 c	2.98 b	4.57 a	0.57 d	1.42 c	2.72 b	4.63 a	5.67 a	1.73 b	3.25 a	4.4 a	6.61 a
	16			0.21 e	1.28 d	2.12 d		0.54 e	1.78 d	2.69 c	0.42 b	0.94 d	2.35 c	4.21 b	5.38 a	1.21 d	2.84 c	4.01 a	6.26 a
	24			0.66 e	1.58 e				1.12 e	2.11 e	3.72 d			1.62 e	3.37 d	4.79 c	0.16 e	2.02 d	3.25 c
14	12		0.16 e	1.06 e	1.75 d		0.44 e	1.45 e	2.2 d	3.46 c	0.02 e	0.78 e	1.9 d	3.4 c	4.34 b	1.01 d	2.3 c	3.26 b	5.08 a
	16			0.71 f	1.45 e			1.08 e	1.87 e	3.15 d		0.22 e	1.5 e	2.93 d	4.02 c	0.39 e	1.84 d	2.84 d	4.7 b
	24				0.84 f			0.35 f	1.22 f	2.53 e			0.68 f	2 e	3.37 e		0.93 e	1.99 e	3.93 d
16	12			0.61 f	1.22 e			0.92 f	1.57 e	2.6 d		0.23 f	1.26 e	2.43 e	3.31 d	0.37 e	1.55 e	2.37 d	3.89 c
	16			0.23 f	0.9 f			0.52 f	1.22 f	2.26 e			0.82 f	1.94 e	2.96 e		1.06 e	1.91 e	3.47 d
	24				0.24 f				0.52 f	1.59 f				0.94 f	2.27 f		0.07 f	1 f	2.65 e

Wall Height (ft)	Spacing (in.) o.c.	362S300-(mils)			600S137-(mils)				600S162-(mils)					600S200-(mils)			
		50 ksi			33 ksi		50 ksi		33 ksi		50 ksi			33 ksi			
		54	68	97	33	43	54	68	97	33	43	54	68	97	118	33	43
8	12	5.26 a	7.47 a	11.32 a	1.46 a	2.21 a	3.55 a	4.79 a	7.3 a	2.11 a	3.09 a	5.3 a	7.14 a	11.06 a	13.89 a	2.51 a	3.92 a
	16	5.02 a	7.22 a	11.1 a	1.33 a	2.08 a	3.44 a	4.68 a	7.21 a	1.97 a	2.96 a	5.16 a	7.01 a	10.93 a	13.76 a	2.35 a	3.75 a
	24	4.55 a	6.74 a	10.66 a	1.05 a	1.81 a	3.23 a	4.47 a	7.02 a	1.68 a	2.68 a	4.9 a	6.76 a	10.67 a	13.49 a	2.03 a	3.42 a
9	12	4.85 a	6.86 a	10.56 a	1.35 a	2.1 a	3.47 a	4.7 a	7.23 a	1.99 a	2.98 a	5.19 a	7.04 a	10.95 a	13.79 a	2.36 a	3.75 a
	16	4.57 a	6.57 a	10.29 a	1.18 a	1.93 a	3.33 a	4.57 a	7.11 a	1.81 a	2.81 a	5.02 a	6.88 a	10.79 a	13.62 a	2.17 a	3.55 a
	24	3.99 a	6 a	9.77 a	0.83 a	1.6 a	3.05 a	4.3 a	6.86 a	1.45 a	2.46 a	4.69 a	6.56 a	10.46 a	13.28 a	1.77 a	3.14 a
10	12	4.42 a	6.24 a	9.6 a	1.23 a	1.98 a	3.37 a	4.61 a	7.14 a	1.85 a	2.84 a	5.06 a	6.93 a	10.84 a	13.67 a	2.21 a	3.57 a
	16	4.08 a	5.9 a	9.3 a	1.02 a	1.78 a	3.2 a	4.44 a	6.99 a	1.63 a	2.63 a	4.85 a	6.73 a	10.64 a	13.46 a	1.96 a	3.32 a
	24	3.41 a	5.24 a	8.7 a	0.59 a	1.36 a	2.86 a	4.11 a	6.69 a	1.18 a	2.2 a	4.44 a	6.34 a	10.23 a	13.04 a	1.48 a	2.81 a
12	12	3.57 a	5 a	7.64 a	0.95 a	1.71 a	3.15 a	4.39 a	6.94 a	1.52 a	2.51 a	4.64 a	6.54 a	10.57 a	13.39 a	1.84 a	3.14 a
	16	3.14 b	4.59 a	7.27 a	0.64 a	1.41 a	2.9 a	4.15 a	6.73 a	1.21 a	2.2 a	4.35 a	6.26 a	10.28 a	13.09 a	1.5 a	2.79 a
	24	2.27 d	3.76 c	6.55 a	0.02 c	0.81 b	2.41 a	3.67 a	6.29 a	0.58 c	1.6 a	3.78 a	5.71 a	9.69 a	12.49 a	0.81 b	2.09 a
14	12	2.66 c	3.79 b	5.94 a	0.61 b	1.39 a	2.88 a	4.13 a	6.71 a	1.15 a	2.11 a	4.13 a	5.95 a	9.93 a	13.07 a	1.42 a	2.65 a
	16	2.16 d	3.32 c	5.54 b	0.19 d	0.98 b	2.55 a	3.8 a	6.41 a	0.73 c	1.71 b	3.75 a	5.59 a	9.54 a	12.66 a	0.97 b	2.19 a
	24	1.14 e	2.39 e	4.73 d		0.17 d	1.89 c	3.15 b	5.82 a		0.92 d	3.01 c	4.87 a	8.77 a	11.84 a	0.07 d	1.27 c
16	12	1.83 e	2.78 d	4.6 b	0.22 d	1.01 c	2.58 b	3.83 a	6.44 a	0.73 c	1.67 b	3.53 a	5.23 a	8.89 a	11.74 a	0.96 c	2.1 a
	16	1.28 e	2.27 e	4.16 d		0.48 d	2.14 c	3.4 b	6.05 a	0.22 d	1.17 d	3.07 c	4.8 a	8.42 a	11.24 a	0.4 d	1.54 c
	24	0.18 f	1.26 f	3.29 e			1.28 e	2.55 d	5.28 c		0.18 e	2.17 d	3.92 c	7.49 b	10.26 a		0.4 d

Wall Height (ft)	Spacing (in.) o.c.	600S200-(mils)				600S250-(mils)				600S300-(mils)				600S350-(mils)				
		50 ksi				33 ksi		50 ksi		33 ksi		50 ksi		33 ksi		50 ksi		
		54	68	97	118	33	43	54	68	97	118	54	68	97	118	54	68	97
8	12	6.99 a	9.42 a	14.89 a	19.18 a	4.27 a	7.24 a	10.54 a	17.49 a	22.36 a	7.55 a	10.73 a	18.8 a	24.47 a	9.83 a	14.32 a	23.41 a	30.95 a
	16	6.84 a	9.26 a	14.74 a	19.02 a	4.1 a	7.08 a	10.37 a	17.3 a	22.17 a	7.39 a	10.56 a	18.62 a	24.28 a	9.67 a	14.13 a	23.21 a	30.75 a
	24	6.52 a	8.94 a	14.43 a	18.69 a	3.76 a	6.77 a	10.02 a	16.93 a	21.79 a	7.07 a	10.22 a	18.25 a	23.89 a	9.33 a	13.77 a	22.81 a	30.34 a
9	12	6.78 a	9.17 a	14.58 a	18.8 a	4.1 a	7.03 a	10.26 a	17.06 a	21.85 a	7.33 a	10.46 a	18.35 a	23.93 a	9.56 a	13.97 a	22.88 a	30.13 a
	16	6.58 a	8.97 a	14.39 a	18.6 a	3.89 a	6.84 a	10.04 a	16.83 a	21.61 a	7.13 a	10.25 a	18.12 a	23.69 a	9.35 a	13.74 a	22.63 a	29.88 a
	24	6.19 a	8.58 a	14.01 a	18.2 a	3.46 a	6.45 a	9.61 a	16.36 a	21.13 a	6.74 a	9.82 a	17.66 a	23.21 a	8.93 a	13.29 a	22.14 a	29.37 a
10	12	6.53 a	8.89 a	14.21 a	18.35 a	3.91 a	6.8 a	9.94 a	16.56 a	21.24 a	7.09 a	10.15 a	17.82 a	23.31 a	9.25 a	13.57 a	22.3 a	29.21 a
	16	6.29 a	8.64 a	13.98 a	18.1 a	3.65 a	6.56 a	9.68 a	16.28 a	20.95 a	6.85 a	9.89 a	17.54 a	23.03 a	8.99 a	13.3 a	22 a	28.9 a
	24	5.81 a	8.16 a	13.51 a	17.61 a	3.13 a	6.08 a	9.16 a	15.72 a	20.38 a	6.37 a	9.38 a	16.99 a	22.45 a	8.48 a	12.75 a	21.4 a	28.29 a
12	12	5.94 a	8.19 a	13.29 a	17.2 a	3.48 a	6.24 a	9.2 a	15.37 a	19.78 a	6.52 a	9.47 a	16.6 a	21.89 a	8.54 a	12.67 a	20.99 a	27.08 a
	16	5.61 a	7.86 a	12.97 a	16.86 a	3.12 a	5.91 a	8.84 a	14.98 a	19.38 a	6.19 a	9.12 a	16.21 a	21.49 a	8.19 a	12.29 a	20.57 a	26.66 a
	24	4.95 a	7.2 a	12.33 a	16.19 a	2.38 a	5.25 a	8.12 a	14.22 a	18.59 a	5.52 a	8.41 a	15.45 a	20.7 a	7.49 a	11.53 a	19.75 a	25.84 a
14	12	5.24 a	7.35 a	12.12 a	15.73 a	2.99 a	5.63 a	8.34 a	13.94 a	18.01 a	5.86 a	8.7 a	15.19 a	20.32 a	7.73 a	11.63 a	19.32 a	24.66 a
	16	4.81 a	6.92 a	11.72 a	15.31 a	2.5 a	5.2 a	7.87 a	13.46 a	17.51 a	5.43 a	8.24 a	14.7 a	19.81 a	7.28 a	11.14 a	18.79 a	24.14 a
	24	3.97 b	6.08 a	10.9 a	14.45 a	1.53 b	4.34 a	6.95 a	12.48 a	16.51 a	4.57 a	7.31 a	13.72 a	18.78 a	6.37 a	10.16 a	17.74 a	23.1 a
16	12	4.46 a	6.4 a	10.79 a	14.04 a	2.44 a	5 a	7.42 a	12.37 a	16.05 a	5.15 a	7.85 a	13.68 a	18.21 a	6.86 a	10.49 a	17.22 a	22.07 a
	16	3.95 b	5.89 a	10.3 a	13.53 a	1.83 b	4.47 a	6.86 a	11.79 a	15.45 a	4.62 a	7.27 a	13.09 a	17.59 a	6.3 a	9.89 a	16.59 a	21.45 a
	24	2.94 d	4.87 c	9.32 a	12.51 a	0.62 d	3.39 c	5.72 b	10.62 a	14.26 a	3.56 c	6.12 b	11.91 a	16.36 a	5.2 b	8.7 a	15.32 a	20.21 a

See Combined Axial and Lateral Load Table Notes

## 20 psf Lateral Load

Wall Height (ft)	Spacing (in.) o.c.	800S137-(mils)					800S162-(mils)					800S200-(mils)						
		33 ksi		50 ksi			33 ksi		50 ksi			33 ksi		50 ksi				
		33	43	54	68	97	33	43	54	68	97	118	33	43	54	68	97	118
8	12	1.44 a*	2.22 a	3.39 a	4.57 a	7.09 a	2.07 a*	3.1 a	5.2 a	7.02 a	11.05 a	14.11 a	2.62 a*	4.23 a	7.49 a	10.02 a	15.72 a	20.18 a
	16	1.33 a*	2.13 a	3.32 a	4.5 a	7.02 a	1.93 a*	2.99 a	5.11 a	6.92 a	10.96 a	14.02 a	2.47 a*	4.11 a	7.38 a	9.91 a	15.61 a	20.07 a
	24	1.1 a*	1.94 a	3.17 a	4.36 a	6.9 a	1.65 a*	2.77 a	4.91 a	6.73 a	10.79 a	13.85 a	2.16 a*	3.88 a	7.15 a	9.69 a	15.4 a	19.85 a
9	12	1.35 a*	2.15 a	3.34 a	4.52 a	7.04 a	1.96 a*	3.01 a	5.13 a	6.94 a	10.98 a	14.04 a	2.5 a*	4.14 a	7.4 a	9.93 a	15.63 a	20.09 a
	16	1.21 a*	2.03 a	3.24 a	4.43 a	6.96 a	1.78 a*	2.87 a	5 a	6.82 a	10.87 a	13.93 a	2.31 a*	3.99 a	7.26 a	9.79 a	15.5 a	19.95 a
	24	0.92 a*	1.8 a	3.06 a	4.25 a	6.79 a	1.43 a*	2.59 a	4.76 a	6.58 a	10.65 a	13.71 a	1.93 a*	3.7 a	6.97 a	9.51 a	15.23 a	19.67 a
10	12	1.25 a*	2.06 a	3.27 a	4.46 a	6.98 a	1.83 a*	2.92 a	5.04 a	6.86 a	10.9 a	13.96 a	2.36 a*	4.03 a	7.3 a	9.83 a	15.54 a	20 a
	16	1.07 a*	1.92 a	3.16 a	4.35 a	6.88 a	1.62 a*	2.74 a	4.89 a	6.71 a	10.77 a	13.83 a	2.13 a*	3.85 a	7.12 a	9.66 a	15.37 a	19.82 a
	24	0.72 a*	1.63 a	2.93 a	4.12 a	6.68 a	1.18 a*	2.39 a	4.58 a	6.41 a	10.49 a	13.55 a	1.66 a*	3.49 a	6.77 a	9.31 a	15.04 a	19.47 a
12	12	1.02 a*	1.87 a	3.12 a	4.31 a	6.85 a	1.55 a*	2.69 a	4.84 a	6.66 a	10.72 a	13.78 a	2.05 a*	3.79 a	7.06 a	9.6 a	15.32 a	19.76 a
	16	0.76 a*	1.67 a	2.96 a	4.15 a	6.7 a	1.23 a*	2.44 a	4.62 a	6.45 a	10.53 a	13.59 a	1.71 a*	3.53 a	6.81 a	9.35 a	15.08 a	19.51 a
	24	0.24 a*	1.25 a	2.63 a	3.83 a	6.42 a	0.61 a*	1.94 a	4.18 a	6.02 a	10.13 a	13.19 a	1.03 a*	3.01 a	6.3 a	8.85 a	14.6 a	19.01 a
14	12	0.74 a*	1.65 a	2.94 a	4.14 a	6.69 a	1.21 a*	2.42 a	4.6 a	6.43 a	10.51 a	13.57 a	1.66 a*	3.45 a	6.63 a	9.16 a	14.97 a	19.49 a
	16	0.39 a*	1.37 a	2.72 a	3.92 a	6.5 a	0.78 a*	2.07 a	4.3 a	6.14 a	10.24 a	13.3 a	1.21 a*	3.11 a	6.29 a	8.82 a	14.65 a	19.15 a
	24		0.8 a	2.27 a	3.49 a	6.11 a		1.39 a	3.7 a	5.56 a	9.7 a	12.76 a	0.3 a*	2.42 a	5.62 a	8.15 a	14 a	18.47 a
16	12	0.42 a*	1.39 a	2.74 a	3.94 a	6.51 a	0.82 a*	2.1 a	4.33 a	6.17 a	10.26 a	13.32 a	1.22 a*	3.06 a	6.1 a	8.54 a	14.17 a	18.63 a
	16		1.02 a	2.44 a	3.66 a	6.26 a	0.26 b*	1.66 a	3.94 a	5.79 a	9.91 a	12.97 a	0.64 a*	2.62 a	5.67 a	8.12 a	13.76 a	18.19 a
	24		0.28 c	1.86 b	3.09 a	5.75 a		0.77 b	3.16 a	5.03 a	9.21 a	12.27 a		1.74 a	4.82 a	7.28 a	12.94 a	17.33 a

Wall Height (ft)	Spacing (in.) o.c.	800S250-(mils)				800S300-(mils)				800S350-(mils)				
		33 ksi		50 ksi		50 ksi		50 ksi		50 ksi		50 ksi		
		43	54	68	97	118	54	68	97	118	54	68	97	118
8	12	4.61 a	7.86 a	11.46 a	19.24 a	25.11 a	8.2 a	11.73 a	21.01 a	27.47 a	10.64 a	15.44 a	25.53 a	33.97 a
	16	4.49 a	7.75 a	11.33 a	19.11 a	24.97 a	8.08 a	11.61 a	20.87 a	27.33 a	10.51 a	15.31 a	25.38 a	33.82 a
	24	4.24 a	7.51 a	11.09 a	18.83 a	24.68 a	7.83 a	11.37 a	20.59 a	27.03 a	10.26 a	15.05 a	25.09 a	33.51 a
9	12	4.5 a	7.74 a	11.32 a	19.06 a	24.86 a	8.06 a	11.57 a	20.75 a	27.17 a	10.47 a	15.24 a	25.28 a	33.62 a
	16	4.34 a	7.59 a	11.16 a	18.89 a	24.67 a	7.91 a	11.42 a	20.58 a	26.99 a	10.3 a	15.07 a	25.1 a	33.43 a
	24	4.03 a	7.29 a	10.85 a	18.54 a	24.31 a	7.6 a	11.11 a	20.23 a	26.62 a	9.98 a	14.74 a	24.73 a	33.04 a
10	12	4.37 a	7.59 a	11.16 a	18.84 a	24.55 a	7.9 a	11.39 a	20.45 a	26.82 a	10.26 a	15 a	24.95 a	33.21 a
	16	4.18 a	7.41 a	10.97 a	18.63 a	24.33 a	7.71 a	11.2 a	20.23 a	26.6 a	10.07 a	14.8 a	24.72 a	32.98 a
	24	3.79 a	7.04 a	10.59 a	18.21 a	23.88 a	7.33 a	10.82 a	19.81 a	26.15 a	9.67 a	14.4 a	24.27 a	32.5 a
12	12	4.08 a	7.24 a	10.77 a	18.31 a	23.77 a	7.52 a	10.94 a	19.69 a	25.93 a	9.78 a	14.45 a	24.06 a	32.24 a
	16	3.8 a	6.98 a	10.5 a	18.01 a	23.45 a	7.25 a	10.67 a	19.39 a	25.62 a	9.51 a	14.16 a	23.74 a	31.91 a
	24	3.25 a	6.46 a	9.96 a	17.41 a	22.82 a	6.71 a	10.14 a	18.79 a	24.99 a	8.95 a	13.59 a	23.11 a	31.24 a
14	12	3.72 a	6.8 a	10.2 a	17.45 a	22.71 a	7.05 a	10.38 a	18.74 a	24.8 a	9.21 a	13.75 a	23 a	30.78 a
	16	3.35 a	6.46 a	9.84 a	17.05 a	22.3 a	6.69 a	10.02 a	18.34 a	24.38 a	8.84 a	13.38 a	22.58 a	30.34 a
	24	2.61 a	5.77 a	9.12 a	16.25 a	21.47 a	5.98 a	9.32 a	17.55 a	23.55 a	8.1 a	12.62 a	21.74 a	29.47 a
16	12	3.31 a	6.28 a	9.52 a	16.36 a	21.39 a	6.51 a	9.72 a	17.61 a	23.47 a	8.57 a	12.95 a	21.82 a	28.91 a
	16	2.84 a	5.85 a	9.06 a	15.87 a	20.87 a	6.06 a	9.27 a	17.11 a	22.94 a	8.1 a	12.48 a	21.29 a	28.37 a
	24	1.89 a	4.98 a	8.15 a	14.87 a	19.84 a	5.15 a	8.38 a	16.12 a	21.9 a	7.17 a	11.52 a	20.23 a	27.28 a

See Combined Axial and Lateral Load Table Notes

## 25 psf Lateral Load

Wall Height (ft)	Spacing (in.) o.c.	362S137-(mils)				362S162-(mils)					362S200-(mils)				362S250-(mils)				
		33 ksi		50 ksi		33 ksi		50 ksi			33 ksi		50 ksi		33 ksi		50 ksi		
		33	43	54	68	33	43	54	68	97	97	33	54	68	97	43	54	68	97
8	12	0.8 a	1.41 a	2.58 a	3.58 a	1.14 a	1.83 a	3.4 a	4.58 a	6.95 a	1.47 a	2.49 a	4.38 a	7.21 a	8.64 a	2.89 a	5.01 a	6.81 a	9.92 a
	16	0.53 b	1.14 a	2.36 a	3.39 a	0.84 a	1.54 a	3.16 a	4.37 a	6.73 a	1.14 a	2.17 a	4.11 a	6.88 a	8.41 a	2.54 a	4.71 a	6.52 a	9.65 a
	24		0.58 c	1.92 b	3 a	0.24 c	0.97 b	2.67 a	3.93 a	6.28 a	0.48 c	1.53 a	3.55 a	6.23 a	7.94 a	1.85 a	4.11 a	5.93 a	9.11 a
9	12	0.57 c	1.16 a	2.29 a	3.26 a	0.87 b	1.54 a	3.04 a	4.16 a	6.34 a	1.17 a	2.15 a	3.92 a	6.55 a	7.88 a	2.54 a	4.56 a	6.16 a	9.06 a
	16	0.23 d	0.82 c	2.02 b	3.03 a	0.5 c	1.19 b	2.75 a	3.89 a	6.08 a	0.76 c	1.76 a	3.59 a	6.16 a	7.61 a	2.11 a	4.2 a	5.81 a	8.74 a
	24		0.14 d	1.49 d	2.56 c		0.49 d	2.16 c	3.37 b	5.56 a		0.98 c	2.93 b	5.39 a	7.06 a	1.26 b	3.47 a	5.11 a	8.1 a
10	12	0.32 d	0.89 c	1.98 b	2.9 a	0.59 c	1.16 b	2.66 a	3.7 a	5.69 a	0.85 c	1.79 a	3.44 a	5.82 a	7.08 a	2.16 a	4.08 a	5.48 a	8.17 a
	16		0.48 d	1.67 c	2.64 b	0.15 d	0.78 d	2.32 c	3.4 a	5.39 a	0.37 d	1.33 c	3.06 b	5.37 a	6.77 a	1.65 b	3.65 a	5.08 a	7.8 a
	24			1.05 e	2.1 d			1.65 d	2.8 c	4.8 b		0.41 d	2.29 d	4.49 c	6.14 a	0.64 d	2.8 c	4.28 b	7.07 a
12	12		0.32 e	1.36 d	2.18 c	0.01 e	0.65 d	1.86 d	2.76 c	4.35 a	0.2 e	1.06 d	2.44 c	4.32 b	5.45 a	1.34 c	2.94 b	4.11 a	6.35 a
	16			0.97 e	1.85 d		0.09 e	1.45 e	2.4 d	4 c		0.47 e	1.99 d	3.79 c	5.08 b	0.68 d	2.43 d	3.63 c	5.91 a
	24			0.2 f	1.19 e			0.63 f	1.68 e	3.29 d			1.07 e	2.74 e	4.35 d		1.4 e	2.68 d	5.04 c
14	12			0.79 e	1.52 e		0.04 f	1.17 e	1.95 e	3.23 d		0.36 e	1.6 e	3.05 d	4.1 c	0.55 e	1.96 d	2.95 c	4.8 b
	16			0.35 f	1.15 f			0.71 f	1.55 e	2.84 e			1.09 e	2.47 e	3.69 d		1.39 e	2.41 d	4.31 c
	24				0.39 f				0.74 f	2.06 f			0.07 f	1.3 f	2.88 e		0.24 f	1.35 e	3.35 e
16	12			0.32 f	0.98 f			0.62 f	1.31 f	2.34 e			0.93 f	2.06 e	3.05 d		1.18 e	2.03 e	3.58 d
	16				0.57 f			0.12 f	0.87 f	1.93 f			0.38 f	1.44 f	2.61 e		0.57 f	1.46 e	3.06 e
	24									1.09 f			0.19 f	1.74 f			0.31 f	2.02 f	

Wall Height (ft)	Spacing (in.) o.c.	362S300-(mils)			600S137-(mils)				600S162-(mils)				600S200-(mils)				
		50 ksi			33 ksi		50 ksi		33 ksi		50 ksi		33 ksi				
		54	68	97	33	43	54	68	97	33	43	54	68	97	118	33	43
8	12	5.08 a	7.28 a	11.16 a	1.36 a	2.11 a	3.47 a	4.71 a	7.23 a	2.01 a	2.99 a	5.2 a	7.05 a	10.96 a	13.79 a	2.39 a	3.79 a
	16	4.79 a	6.98 a	10.88 a	1.19 a	1.94 a	3.34 a	4.57 a	7.11 a	1.83 a	2.82 a	5.03 a	6.89 a	10.8 a	13.63 a	2.19 a	3.59 a
	24	4.2 a	6.38 a	10.33 a	0.84 a	1.61 a	3.06 a	4.31 a	6.87 a	1.47 a	2.47 a	4.7 a	6.58 a	10.47 a	13.29 a	1.79 a	3.18 a
9	12	4.64 a	6.64 a	10.36 a	1.22 a	1.98 a	3.36 a	4.6 a	7.14 a	1.85 a	2.85 a	5.06 a	6.92 a	10.83 a	13.66 a	2.22 a	3.6 a
	16	4.28 a	6.29 a	10.03 a	1.01 a	1.77 a	3.19 a	4.43 a	6.98 a	1.63 a	2.63 a	4.86 a	6.72 a	10.63 a	13.45 a	1.97 a	3.34 a
	24	3.56 a	5.57 a	9.37 a	0.57 a	1.35 a	2.85 a	4.09 a	6.68 a	1.17 a	2.2 a	4.44 a	6.33 a	10.21 a	13.03 a	1.47 a	2.83 a
10	12	4.17 a	5.99 a	9.38 a	1.07 a	1.83 a	3.24 a	4.48 a	7.03 a	1.68 a	2.68 a	4.9 a	6.78 a	10.69 a	13.51 a	2.02 a	3.38 a
	16	3.75 a	5.57 a	9 a	0.8 a	1.57 a	3.03 a	4.27 a	6.84 a	1.4 a	2.41 a	4.65 a	6.54 a	10.43 a	13.25 a	1.72 a	3.07 a
	24	2.91 c	4.74 a	8.24 a	0.26 b	1.05 a	2.61 a	3.86 a	6.46 a	0.85 a	1.88 a	4.13 a	6.05 a	9.93 a	12.73 a	1.11 a	2.44 a
12	12	3.25 b	4.69 a	7.36 a	0.72 a	1.49 a	2.96 a	4.21 a	6.78 a	1.29 a	2.28 a	4.43 a	6.33 a	10.35 a	13.17 a	1.58 a	2.88 a
	16	2.71 c	4.18 b	6.91 a	0.33 b	1.11 a	2.66 a	3.91 a	6.51 a	0.9 b	1.9 a	4.07 a	5.99 a	9.99 a	12.79 a	1.16 a	2.44 a
	24	1.62 e	3.14 d	6.01 b		0.36 c	2.05 b	3.31 a	5.97 a	0.12 d	1.15 b	3.35 a	5.3 a	9.26 a	12.04 a	0.3 c	1.56 b
14	12	2.28 d	3.44 c	5.64 a	0.3 c	1.08 b	2.63 a	3.88 a	6.49 a	0.84 c	1.81 a	3.85 a	5.68 a	9.64 a	12.76 a	1.08 b	2.3 a
	16	1.65 e	2.85 d	5.13 c		0.57 c	2.22 b	3.47 a	6.12 a	0.32 d	1.32 c	3.38 b	5.23 a	9.16 a	12.25 a	0.52 c	1.73 b
	24	0.38 f	1.68 e	4.13 d			1.39 d	2.66 c	5.38 b		0.32 d	2.45 d	4.33 c	8.2 a	11.23 a		0.58 d
16	12	1.42 e	2.4 d	4.27 c		0.61 d	2.25 c	3.51 b	6.15 a	0.35 d	1.29 c	3.19 b	4.91 a	8.54 a	11.37 a	0.54 d	1.68 c
	16	0.73 f	1.77 e	3.73 d			1.71 d	2.97 c	5.67 b		0.67 d	2.62 d	4.36 c	7.96 a	10.75 a		0.97 d
	24		0.5 f	2.64 e			0.63 e	1.91 e	4.71 d			1.49 e	3.27 d	6.79 c	9.52 b		

Wall Height (ft)	Spacing (in.) o.c.	600S200-(mils)				600S250-(mils)				600S300-(mils)				600S350-(mils)				
		50 ksi				33 ksi		50 ksi		33 ksi		50 ksi		33 ksi		50 ksi		
		54	68	97	118	33	43	54	68	97	118	54	68	97	118	54	68	97
8	12	6.88 a	9.3 a	14.78 a	19.06 a	4.14 a	7.12 a	10.41 a	17.35 a	22.22 a	7.43 a	10.6 a	18.67 a	24.32 a	9.71 a	14.18 a	23.26 a	30.8 a
	16	6.68 a	9.1 a	14.59 a	18.86 a	3.93 a	6.93 a	10.19 a	17.11 a	21.98 a	7.23 a	10.39 a	18.43 a	24.08 a	9.5 a	13.95 a	23.01 a	30.54 a
	24	6.28 a	8.7 a	14.2 a	18.45 a	3.5 a	6.54 a	9.76 a	16.65 a	21.5 a	6.84 a	9.97 a	17.97 a	23.6 a	9.08 a	13.5 a	22.51 a	30.03 a
9	12	6.63 a	9.02 a	14.44 a	18.65 a	3.94 a	6.89 a	10.1 a	16.89 a	21.67 a	7.18 a	10.3 a	18.17 a	23.75 a	9.4 a	13.8 a	22.7 a	29.94 a
	16	6.38 a	8.77 a	14.2 a	18.4 a	3.67 a	6.64 a	9.83 a	16.59 a	21.37 a	6.94 a	10.04 a	17.89 a	23.45 a	9.14 a	13.52 a	22.39 a	29.63 a
	24	5.89 a	8.28 a	13.72 a	17.89 a	3.14 a	6.15 a	9.29 a	16.01 a	20.77 a	6.44 a	9.51 a	17.31 a	22.85 a	8.62 a	12.95 a	21.77 a	28.99 a
10	12	6.35 a	8.7 a	14.04 a	18.16 a	3.72 a	6.62 a	9.75 a	16.35 a	21.03 a	6.91 a	9.96 a	17.61 a	23.1 a	9.06 a	13.37 a	22.07 a	28.98 a
	16	6.05 a	8.4 a	13.75 a	17.86 a	3.39 a	6.32 a	9.42 a	16 a	20.67 a	6.61 a	9.64 a	17.27 a	22.74 a	8.74 a	13.03 a	21.7 a	28.6 a
	24	5.45 a	7.8 a	13.17 a	17.25 a	2.74 a	5.73 a	8.77 a	15.3 a	19.94 a	6.01 a	9 a	16.57 a	22.01 a	8.1 a	12.34 a	20.95 a	27.83 a
12	12	5.69 a	7.94 a	13.05 a	16.94 a	3.21 a	5.99 a	8.93 a	15.08 a	19.48 a	6.27 a	9.21 a	16.31 a	21.59 a	8.27 a	12.38 a	20.68 a	26.77 a
	16	5.28 a	7.53 a	12.65 a	16.52 a	2.75 a	5.58 a	8.48 a	14.6 a	18.99 a	5.85 a	8.76 a	15.83 a	21.1 a	7.84 a	11.91 a	20.16 a	26.25 a
	24	4.45 a	6.7 a	11.85 a	15.69 a	1.83 a	4.76 a	7.58 a	13.64 a	18 a	5.02 a	7.87 a	14.88 a	20.1 a	6.96 a	10.96 a	19.13 a	25.22 a
14	12	4.92 a	7.03 a	11.82 a	15.41 a	2.62 a	5.31 a	7.99 a	13.58 a	17.64 a	5.54 a	8.35 a	14.82 a	19.94 a	7.39 a	11.26 a	18.93 a	24.27 a
	16	4.39 a	6.5 a	11.31 a	14.88 a	2.02 a	4.77 a	7.41 a	12.97 a	17.01 a	5 a	7.77 a	14.21 a	19.3 a	6.83 a	10.65 a	18.27 a	23.62 a
	24	3.33 c	5.44 b	10.29 a	13.81 a	0.81 c	3.7 b	6.25 a	11.75 a	15.76 a	3.92 b	6.61 a	12.99 a	18.01 a	5.7 a	9.43 a	16.94 a	22.32 a
16	12	4.08 a	6.02 a	10.42 a	13.66 a	1.98 b	4.6 a	7 a	11.93 a	15.6 a	4.75 a	7.42 a	13.24 a	17.75 a	6.44 a	10.04 a	16.74 a	21.6 a
	16	3.44 c	5.38 b	9.81 a	13.02 a	1.22 c	3.93 b	6.29 a	11.2 a	14.86 a	4.09 b	6.7 a	12.5 a	16.98 a	5.75 a	9.29 a	15.95 a	20.83 a
	24	2.17 d	4.11 d	8.59 b	11.74 a		2.59 d	4.87 c	9.74 b	13.36 a	2.76 d	5.26 c	11.03 a	15.44 a	4.37 c	7.8 b	14.37 a	19.27 a

See Combined Axial and Lateral Load Table Notes

## 25 psf Lateral Load

Wall Height (ft)	Spacing (in.) o.c.	800S137-(mils)					800S162-(mils)					800S200-(mils)						
		33 ksi		50 ksi			33 ksi		50 ksi			33 ksi		50 ksi				
		33	43	54	68	97	33	43	54	68	97	118	33	43	54	68	97	118
8	12	1.36 a*	2.15 a	3.34 a	4.52 a	7.04 a	1.96 a*	3.02 a	5.13 a	6.95 a	10.98 a	14.05 a	2.5 a*	4.14 a	7.41 a	9.94 a	15.64 a	20.1 a
	16	1.22 a*	2.03 a	3.25 a	4.43 a	6.96 a	1.79 a*	2.88 a	5.01 a	6.83 a	10.88 a	13.94 a	2.32 a*	4 a	7.26 a	9.8 a	15.5 a	19.96 a
	24	0.93 a*	1.8 a	3.06 a	4.26 a	6.8 a	1.44 a*	2.6 a	4.76 a	6.59 a	10.66 a	13.72 a	1.94 a*	3.71 a	6.98 a	9.52 a	15.24 a	19.68 a
9	12	1.24 a*	2.06 a	3.27 a	4.45 a	6.98 a	1.83 a*	2.91 a	5.03 a	6.85 a	10.9 a	13.96 a	2.35 a*	4.03 a	7.29 a	9.83 a	15.53 a	19.99 a
	16	1.06 a*	1.91 a	3.15 a	4.34 a	6.87 a	1.61 a*	2.73 a	4.88 a	6.7 a	10.76 a	13.82 a	2.12 a*	3.85 a	7.12 a	9.65 a	15.36 a	19.81 a
	24	0.7 a*	1.62 a	2.92 a	4.12 a	6.67 a	1.17 a*	2.38 a	4.57 a	6.4 a	10.48 a	13.54 a	1.64 a*	3.48 a	6.76 a	9.3 a	15.02 a	19.46 a
10	12	1.12 a*	1.96 a	3.18 a	4.37 a	6.9 a	1.67 a*	2.79 a	4.92 a	6.75 a	10.8 a	13.86 a	2.19 a*	3.9 a	7.17 a	9.7 a	15.41 a	19.86 a
	16	0.89 a*	1.78 a	3.04 a	4.23 a	6.78 a	1.4 a*	2.57 a	4.73 a	6.56 a	10.63 a	13.69 a	1.89 a*	3.67 a	6.95 a	9.48 a	15.2 a	19.65 a
	24	0.45 a*	1.41 a	2.76 a	3.96 a	6.53 a	0.86 a*	2.13 a	4.35 a	6.19 a	10.29 a	13.35 a	1.31 a*	3.23 a	6.51 a	9.05 a	14.79 a	19.21 a
12	12	0.82 a*	1.72 a	3 a	4.19 a	6.74 a	1.31 a*	2.5 a	4.67 a	6.5 a	10.57 a	13.64 a	1.79 a*	3.59 a	6.87 a	9.41 a	15.14 a	19.58 a
	16	0.5 a*	1.46 a	2.79 a	3.99 a	6.56 a	0.92 a*	2.19 a	4.4 a	6.24 a	10.33 a	13.39 a	1.37 a*	3.27 a	6.55 a	9.1 a	14.84 a	19.26 a
	24	0.94 a		2.38 a	3.6 a	6.2 a	0.14 a*	1.56 a	3.85 a	5.7 a	9.84 a	12.9 a	0.53 a*	2.63 a	5.92 a	8.48 a	14.24 a	18.64 a
14	12	0.47 a*	1.44 a	2.77 a	3.98 a	6.55 a	0.89 a*	2.16 a	4.38 a	6.21 a	10.31 a	13.37 a	1.32 a*	3.19 a	6.38 a	8.91 a	14.73 a	19.24 a
	16	0.04 a*	1.08 a	2.49 a	3.71 a	6.3 a	0.36 a*	1.73 a	4 a	5.85 a	9.97 a	13.03 a	0.75 a*	2.76 a	5.96 a	8.49 a	14.32 a	18.81 a
	24	0.38 b		1.94 a	3.17 a	5.82 a	0.88 a		3.26 a	5.13 a	9.3 a	12.36 a		1.9 a	5.11 a	7.65 a	13.51 a	17.96 a
16	12	0.07 b*	1.11 a	2.52 a	3.73 a	6.32 a	0.4 a*	1.77 a	4.03 a	5.88 a	10 a	13.06 a	0.79 a*	2.73 a	5.78 a	8.23 a	13.86 a	18.3 a
	16		0.65 b	2.15 a	3.38 a	6.01 a		1.21 a	3.55 a	5.41 a	9.56 a	12.62 a	0.06 b*	2.18 a	5.25 a	7.7 a	13.35 a	17.76 a
	24			1.42 c	2.67 b	5.37 a		0.1 c	2.57 b	4.46 a	8.69 a	11.75 a		1.08 c	4.18 a	6.65 a	12.33 a	16.68 a

Wall Height (ft)	Spacing (in.) o.c.	800S250-(mils)				800S300-(mils)				800S350-(mils)				
		33 ksi		50 ksi		33 ksi		50 ksi		33 ksi		50 ksi		
		43	54	68	97	118	54	68	97	118	54	68	97	118
8	12	4.52 a	7.78 a	11.36 a	19.14 a	25 a	8.11 a	11.64 a	20.9 a	27.36 a	10.55 a	15.34 a	25.42 a	33.86 a
	16	4.36 a	7.63 a	11.21 a	18.97 a	24.82 a	7.96 a	11.49 a	20.73 a	27.18 a	10.39 a	15.18 a	25.24 a	33.67 a
	24	4.05 a	7.33 a	10.9 a	18.63 a	24.46 a	7.65 a	11.18 a	20.38 a	26.82 a	10.06 a	14.85 a	24.87 a	33.28 a
9	12	4.38 a	7.63 a	11.2 a	18.93 a	24.72 a	7.95 a	11.46 a	20.62 a	27.04 a	10.34 a	15.11 a	25.14 a	33.48 a
	16	4.19 a	7.44 a	11.01 a	18.71 a	24.49 a	7.75 a	11.26 a	20.4 a	26.81 a	10.14 a	14.91 a	24.91 a	33.23 a
	24	3.79 a	7.07 a	10.62 a	18.28 a	24.04 a	7.36 a	10.88 a	19.96 a	26.35 a	9.74 a	14.49 a	24.45 a	32.75 a
10	12	4.23 a	7.45 a	11.02 a	18.69 a	24.38 a	7.76 a	11.25 a	20.29 a	26.65 a	10.12 a	14.85 a	24.78 a	33.03 a
	16	3.99 a	7.23 a	10.78 a	18.42 a	24.11 a	7.52 a	11.01 a	20.02 a	26.37 a	9.87 a	14.6 a	24.5 a	32.74 a
	24	3.5 a	6.77 a	10.3 a	17.89 a	23.55 a	7.05 a	10.54 a	19.49 a	25.81 a	9.37 a	14.1 a	23.93 a	32.15 a
12	12	3.87 a	7.05 a	10.57 a	18.09 a	23.53 a	7.32 a	10.74 a	19.47 a	25.69 a	9.57 a	14.23 a	23.82 a	31.99 a
	16	3.52 a	6.72 a	10.23 a	17.71 a	23.14 a	6.98 a	10.4 a	19.09 a	25.3 a	9.23 a	13.87 a	23.43 a	31.58 a
	24	2.83 a	6.07 a	9.55 a	16.96 a	22.35 a	6.31 a	9.74 a	18.34 a	24.51 a	8.53 a	13.16 a	22.63 a	30.74 a
14	12	3.44 a	6.54 a	9.93 a	17.15 a	22.4 a	6.78 a	10.11 a	18.44 a	24.49 a	8.94 a	13.47 a	22.69 a	30.45 a
	16	2.98 a	6.11 a	9.48 a	16.65 a	21.88 a	6.34 a	9.67 a	17.95 a	23.97 a	8.47 a	13 a	22.16 a	29.91 a
	24	2.05 a	5.25 a	8.58 a	15.66 a	20.85 a	5.44 a	8.79 a	16.96 a	22.93 a	7.55 a	12.05 a	21.11 a	28.81 a
16	12	2.96 a	5.96 a	9.18 a	15.99 a	21 a	6.17 a	9.39 a	17.24 a	23.07 a	8.22 a	12.6 a	21.42 a	28.5 a
	16	2.37 a	5.41 a	8.61 a	15.37 a	20.35 a	5.61 a	8.83 a	16.62 a	22.42 a	7.63 a	12 a	20.76 a	27.82 a
	24	1.18 b	4.32 a	7.47 a	14.12 a	19.06 a	4.47 a	7.72 a	15.38 a	21.12 a	6.47 a	10.81 a	19.43 a	26.47 a

See Combined Axial and Lateral Load Table Notes

## 30 psf Lateral Load

Wall Height (ft)	Spacing (in.) o.c.	362S137-(mils)				362S162-(mils)					362S200-(mils)				362S250-(mils)				
		33 ksi		50 ksi		33 ksi		50 ksi			33 ksi		50 ksi		33 ksi		50 ksi		
		33	43	54	68	33	43	54	68	97	97	33	54	68	97	43	54	68	97
8	12	0.63 b	1.25 a	2.45 a	3.47 a	0.96 a	1.66 a	3.25 a	4.45 a	6.82 a	1.27 a	2.3 a	4.22 a	7.01 a	8.5 a	2.68 a	4.83 a	6.64 a	9.76 a
	16	0.31 c	0.92 b	2.18 a	3.24 a	0.6 b	1.31 a	2.96 a	4.19 a	6.55 a	0.87 b	1.92 a	3.88 a	6.62 a	8.22 a	2.26 a	4.47 a	6.29 a	9.43 a
	24		0.25 d	1.65 c	2.77 b		0.63 c	2.38 b	3.67 a	6.02 a	0.08 d	1.15 b	3.22 a	5.84 a	7.66 a	1.43 b	3.75 a	5.58 a	8.78 a
9	12	0.36 c	0.96 b	2.13 a	3.12 a	0.65 c	1.33 a	2.86 a	4 a	6.19 a	0.93 b	1.92 a	3.72 a	6.32 a	7.72 a	2.28 a	4.35 a	5.95 a	8.87 a
	16		0.55 d	1.81 c	2.84 b	0.21 d	0.91 c	2.51 b	3.69 a	5.87 a	0.44 c	1.45 b	3.32 a	5.85 a	7.39 a	1.77 a	3.91 a	5.53 a	8.49 a
	24			1.17 d	2.29 d		0.07 d	1.82 d	3.06 c	5.24 a		0.51 d	2.53 c	4.92 b	6.73 a	0.75 c	3.04 b	4.7 a	7.72 a
10	12	0.07 e	0.65 d	1.79 c	2.74 b	0.33 d	0.93 c	2.45 b	3.52 a	5.51 a	0.56 c	1.52 b	3.21 a	5.55 a	6.89 a	1.86 a	3.82 a	5.24 a	7.95 a
	16		0.16 e	1.42 d	2.42 c		0.47 d	2.05 c	3.16 b	5.15 a		0.96 d	2.75 c	5.02 b	6.52 a	1.25 c	3.31 b	4.76 a	7.51 a
	24			0.68 e	1.77 e			1.24 e	2.44 d	4.44 c			1.84 d	3.96 d	5.77 b	0.03 d	2.29 d	3.81 c	6.64 a
12	12			1.13 e	1.98 d		0.32 e	1.61 d	2.54 d	4.14 b		0.7 d	2.17 d	4 c	5.23 a	0.94 d	2.63 c	3.82 b	6.09 a
	16			0.66 e	1.58 e			1.12 e	2.11 e	3.72 d			1.62 e	3.37 d	4.79 c	0.16 e	2.02 d	3.25 c	5.56 b
	24				0.79 f			0.14 f	1.24 f	2.87 e			0.53 f	2.11 e	3.9 d		0.79 e	2.11 e	4.52 d
14	12			0.53 f	1.3 e			0.9 f	1.71 e	3 d			1.29 e	2.7 e	3.86 d	0.08 e	1.61 e	2.63 d	4.51 c
	16				0.84 f			0.35 f	1.22 f	2.53 e			0.68 f	2 e	3.37 e		0.93 e	1.99 e	3.93 d
	24								0.25 f	1.59 f				0.6 f	2.39 f		-0.44 f	0.72 f	2.77 e
16	12			0.03 f	0.73 f			0.32 f	1.04 f	2.09 e			0.6 f	1.69 f	2.79 e		0.81 f	1.68 e	3.27 d
	16				0.24 f				0.52 f	1.59 f				0.94 f	2.27 f		0.07 f	1 f	2.65 e
	24									0.59 f				1.22 f					1.4 f

Wall Height (ft)	Spacing (in.) o.c.	362S300-(mils)			600S137-(mils)				600S162-(mils)					600S200-(mils)			
		50 ksi			33 ksi		50 ksi		33 ksi		50 ksi			33 ksi			
		54	68	97	33	43	54	68	97	33	43	54	68	97	118	33	43
8	12	4.9 a	7.1 a	10.99 a	1.26 a	2.01 a	3.39 a	4.63 a	7.16 a	1.9 a	2.89 a	5.1 a	6.95 a	10.86 a	13.69 a	2.27 a	3.67 a
	16	4.55 a	6.74 a	10.66 a	1.05 a	1.81 a	3.23 a	4.47 a	7.02 a	1.68 a	2.68 a	4.9 a	6.76 a	10.67 a	13.49 a	2.03 a	3.42 a
	24	3.84 a	6.02 a	10 a	0.64 a	1.41 a	2.9 a	4.15 a	6.73 a	1.25 a	2.27 a	4.5 a	6.39 a	10.28 a	13.09 a	1.56 a	2.93 a
9	12	4.42 a	6.43 a	10.16 a	1.09 a	1.85 a	3.26 a	4.5 a	7.04 a	1.72 a	2.72 a	4.94 a	6.8 a	10.71 a	13.54 a	2.07 a	3.45 a
	16	3.99 a	6 a	9.77 a	0.83 a	1.6 a	3.05 a	4.3 a	6.86 a	1.45 a	2.46 a	4.69 a	6.56 a	10.46 a	13.28 a	1.77 a	3.14 a
	24	3.14 b	5.13 a	8.97 a	0.31 a	1.09 a	2.64 a	3.89 a	6.5 a	0.9 a	1.94 a	4.19 a	6.09 a	9.97 a	12.78 a	1.17 a	2.52 a
10	12	3.91 a	5.74 a	9.15 a	0.91 a	1.67 a	3.12 a	4.36 a	6.92 a	1.52 a	2.52 a	4.75 a	6.63 a	10.53 a	13.36 a	1.84 a	3.19 a
	16	3.41 a	5.24 a	8.7 a	0.59 a	1.36 a	2.86 a	4.11 a	6.69 a	1.18 a	2.2 a	4.44 a	6.34 a	10.23 a	13.04 a	1.48 a	2.81 a
	24	2.41 c	4.24 b	7.79 a		0.74 a	2.35 a	3.61 a	6.24 a	0.52 b	1.56 a	3.82 a	5.75 a	9.62 a	12.42 a	0.74 a	2.06 a
12	12	2.92 c	4.38 a	7.09 a	0.48 b	1.26 a	2.78 a	4.03 a	6.62 a	1.05 a	2.05 a	4.21 a	6.13 a	10.13 a	12.94 a	1.33 a	2.61 a
	16	2.27 d	3.76 c	6.55 a	0.02 c	0.81 b	2.41 a	3.67 a	6.29 a	0.58 c	1.6 a	3.78 a	5.71 a	9.69 a	12.49 a	0.81 b	2.09 a
	24	0.97 e	2.52 d	5.47 c			1.68 c	2.95 b	5.64 a		0.7 c	2.92 b	4.88 a	8.82 a	11.59 a		1.03 c
14	12	1.9 e	3.09 d	5.34 b		0.78 c	2.38 b	3.64 a	6.27 a	0.53 c	1.51 b	3.57 a	5.41 a	9.35 a	12.46 a	0.75 c	1.96 a
	16	1.14 e	2.39 e	4.73 d		0.17 d	1.89 c	3.15 b	5.82 a		0.92 d	3.01 c	4.87 a	8.77 a	11.84 a	0.07 d	1.27 c
	24		0.98 f	3.52 e			0.89 e	2.17 d	4.94 c			1.89 d	3.79 c	7.62 b	10.62 a		
16	12	1 f	2.02 e	3.95 d		0.21 d	1.93 d	3.19 c	5.86 a		0.92 d	2.85 c	4.58 b	8.19 a	11 a	0.12 d	1.25 c
	16	0.18 f	1.26 f	3.29 e			1.28 e	2.55 d	5.28 c		0.18 e	2.17 d	3.92 c	7.49 b	10.26 a		0.4 d
	24			1.99 f				1.27 e	4.13 d			0.81 e	2.61 e	6.09 d	8.78 c		

Wall Height (ft)	Spacing (in.) o.c.	600S200-(mils)				600S250-(mils)				600S300-(mils)				600S350-(mils)				
		50 ksi				33 ksi		50 ksi		33 ksi		50 ksi		33 ksi		50 ksi		
		54	68	97	118	33	43	54	68	97	118	54	68	97	118	54	68	97
8	12	6.76 a	9.18 a	14.66 a	18.94 a	4.01 a	7.01 a	10.28 a	17.21 a	22.07 a	7.31 a	10.48 a	18.53 a	24.18 a	9.58 a	14.04 a	23.11 a	30.65 a
	16	6.52 a	8.94 a	14.43 a	18.69 a	3.76 a	6.77 a	10.02 a	16.93 a	21.79 a	7.07 a	10.22 a	18.25 a	23.89 a	9.33 a	13.77 a	22.81 a	30.34 a
	24	6.04 a	8.46 a	13.97 a	18.21 a	3.25 a	6.3 a	9.51 a	16.37 a	21.21 a	6.6 a	9.72 a	17.69 a	23.32 a	8.83 a	13.23 a	22.22 a	29.73 a
9	12	6.48 a	8.87 a	14.29 a	18.5 a	3.78 a	6.74 a	9.94 a	16.71 a	21.49 a	7.04 a	10.14 a	18 a	23.57 a	9.24 a	13.63 a	22.51 a	29.75 a
	16	6.19 a	8.58 a	14.01 a	18.2 a	3.46 a	6.45 a	9.61 a	16.36 a	21.13 a	6.74 a	9.82 a	17.66 a	23.21 a	8.93 a	13.29 a	22.14 a	29.37 a
	24	5.59 a	7.98 a	13.43 a	17.59 a	2.82 a	5.86 a	8.97 a	15.67 a	20.41 a	6.15 a	9.19 a	16.96 a	22.49 a	8.3 a	12.61 a	21.4 a	28.61 a
10	12	6.17 a	8.52 a	13.86 a	17.98 a	3.52 a	6.44 a	9.55 a	16.14 a	20.81 a	6.73 a	9.76 a	17.4 a	22.88 a	8.87 a	13.16 a	21.85 a	28.75 a
	16	5.81 a	8.16 a	13.51 a	17.61 a	3.13 a	6.08 a	9.16 a	15.72 a	20.38 a	6.37 a	9.38 a	16.99 a	22.45 a	8.48 a	12.75 a	21.4 a	28.29 a
	24	5.09 a	7.44 a	12.82 a	16.88 a	2.34 a	5.37 a	8.38 a	14.88 a	19.51 a	5.65 a	8.61 a	16.15 a	21.58 a	7.72 a	11.93 a	20.5 a	27.38 a
12	12	5.44 a	7.69 a	12.81 a	16.69 a	2.93 a	5.75 a	8.66 a	14.79 a	19.18 a	6.02 a	8.94 a	16.02 a	21.3 a	8.01 a	12.1 a	20.37 a	26.46 a
	16	4.95 a	7.2 a	12.33 a	16.19 a	2.38 a	5.25 a	8.12 a	14.22 a	18.59 a	5.52 a	8.41 a	15.45 a	20.7 a	7.49 a	11.53 a	19.75 a	25.84 a
	24	3.95 b	6.2 a	11.37 a	15.18 a	1.28 b	4.26 a	7.04 a	13.06 a	17.41 a	4.52 a	7.34 a	14.31 a	19.5 a	6.43 a	10.4 a	18.51 a	24.6 a
14	12	4.6 a	6.71 a	11.51 a	15.09 a	2.26 a	4.99 a	7.64 a	13.21 a	17.26 a	5.22 a	8 a	14.46 a	19.55 a	7.05 a	10.89 a	18.53 a	23.88 a
	16	3.97 b	6.08 a	10.9 a	14.45 a	1.53 b	4.34 a	6.95 a	12.48 a	16.51 a	4.57 a	7.31 a	13.72 a	18.78 a	6.37 a	10.16 a	17.74 a	23.1 a
	24	2.7 d	4.8 c	9.68 a	13.17 a	0.08 d	3.05 c	5.55 b	11.02 a	15.01 a	3.27 c	5.92 b	12.26 a	17.24 a	5.02 b	8.7 a	16.15 a	21.53 a
16	12	3.7 b	5.64 a	10.06 a	13.27 a	1.53 c	4.2 b	6.57 a	11.49 a	15.15 a	4.35 a	6.99 a	12.8 a	17.29 a	6.03 a	9.59 a	16.27 a	21.14 a
	16	2.94 d	4.87 c	9.32 a	12.51 a	0.62 d	3.39 c	5.72 b	10.62 a	14.26 a	3.56 c	6.12 b	11.91 a	16.36 a	5.2 b	8.7 a	15.32 a	20.21 a
	24	1.41 e	3.35 d	7.86 c	10.98 b		1.78 e	4.01 d	8.87 c	12.46 b	1.96 d	4.4 d	10.14 b	14.52 a	3.54 d	6.9 c	13.43 a	18.34 a

See Combined Axial and Lateral Load Table Notes

## 30 psf Lateral Load

Wall Height (ft)	Spacing (in.) o.c.	800S137-(mils)					800S162-(mils)					800S200-(mils)						
		33 ksi		50 ksi			33 ksi		50 ksi			33 ksi		50 ksi				
		33	43	54	68	97	33	43	54	68	97	118	33	43	54	68	97	118
8	12	1.27 a*	2.08 a	3.28 a	4.47 a	6.99 a	1.86 a*	2.94 a	5.06 a	6.88 a	10.92 a	13.98 a	2.39 a*	4.06 a	7.32 a	9.85 a	15.56 a	20.02 a
	16	1.1 a*	1.94 a	3.17 a	4.36 a	6.9 a	1.65 a*	2.77 a	4.91 a	6.73 a	10.79 a	13.85 a	2.16 a*	3.88 a	7.15 a	9.69 a	15.4 a	19.85 a
	24	0.76 a*	1.67 a	2.96 a	4.15 a	6.7 a	1.23 a*	2.44 a	4.62 a	6.45 a	10.53 a	13.59 a	1.71 a*	3.54 a	6.81 a	9.35 a	15.08 a	19.51 a
9	12	1.14 a*	1.97 a	3.2 a	4.38 a	6.91 a	1.69 a*	2.8 a	4.94 a	6.76 a	10.81 a	13.88 a	2.21 a*	3.92 a	7.19 a	9.72 a	15.43 a	19.88 a
	16	0.92 a*	1.8 a	3.06 a	4.25 a	6.79 a	1.43 a*	2.59 a	4.76 a	6.58 a	10.65 a	13.71 a	1.93 a*	3.7 a	6.97 a	9.51 a	15.23 a	19.67 a
	24	0.48 a*	1.45 a	2.78 a	3.98 a	6.55 a	0.9 a*	2.17 a	4.39 a	6.22 a	10.32 a	13.38 a	1.35 a*	3.26 a	6.54 a	9.09 a	14.82 a	19.25 a
10	12	0.98 a*	1.85 a	3.1 a	4.29 a	6.83 a	1.51 a*	2.66 a	4.81 a	6.64 a	10.7 a	13.76 a	2.01 a*	3.76 a	7.04 a	9.57 a	15.29 a	19.73 a
	16	0.72 a*	1.63 a	2.93 a	4.12 a	6.68 a	1.18 a*	2.39 a	4.58 a	6.41 a	10.49 a	13.55 a	1.66 a*	3.49 a	6.77 a	9.31 a	15.04 a	19.47 a
	24	0.18 a*	1.2 a	2.59 a	3.79 a	6.38 a	0.53 a*	1.87 a	4.12 a	5.97 a	10.08 a	13.14 a	0.95 a*	2.96 a	6.24 a	8.79 a	14.54 a	18.95 a
12	12	0.63 a*	1.56 a	2.87 a	4.07 a	6.63 a	1.08 a*	2.31 a	4.51 a	6.34 a	10.43 a	13.49 a	1.54 a*	3.4 a	6.68 a	9.23 a	14.96 a	19.39 a
	16	0.24 a*	1.25 a	2.63 a	3.83 a	6.42 a	0.61 a*	1.94 a	4.18 a	6.02 a	10.13 a	13.19 a	1.03 a*	3.01 a	6.3 a	8.85 a	14.6 a	19.01 a
	24	0.63 a		2.13 a	3.36 a	5.99 a		1.19 a	3.52 a	5.38 a	9.54 a	12.6 a	0.02 a*	2.24 a	5.54 a	8.1 a	13.88 a	18.26 a
14	12	0.21 a*	1.22 a	2.61 a	3.81 a	6.4 a	0.57 a*	1.9 a	4.15 a	6 a	10.11 a	13.17 a	0.98 a*	2.93 a	6.12 a	8.66 a	14.48 a	18.98 a
	16		0.8 a	2.27 a	3.49 a	6.11 a		1.39 a	3.7 a	5.56 a	9.7 a	12.76 a	0.3 a*	2.42 a	5.62 a	8.15 a	14 a	18.47 a
	24			1.6 b	2.84 a	5.52 a		0.37 b	2.81 a	4.69 a	8.9 a	11.96 a		1.38 a	4.61 a	7.15 a	13.03 a	17.44 a
16	12		0.84 a	2.3 a	3.52 a	6.13 a		1.44 a	3.74 a	5.6 a	9.74 a	12.8 a	0.35 a*	2.4 a	5.46 a	7.91 a	13.56 a	17.98 a
	16		0.28 c	1.86 b	3.09 a	5.75 a		0.77 b	3.16 a	5.03 a	9.21 a	12.27 a		1.74 a	4.82 a	7.28 a	12.94 a	17.33 a
	24			0.98 d	2.25 c	4.99 a			1.99 c	3.89 b	8.16 a	11.22 a		0.42 c	3.55 b	6.01 a	11.72 a	16.03 a

Wall Height (ft)	Spacing (in.) o.c.	800S250-(mils)				800S300-(mils)				800S350-(mils)				
		33 ksi		50 ksi		33 ksi		50 ksi		33 ksi		50 ksi		
		43	54	68	97	118	54	68	97	118	54	68	97	118
8	12	4.43 a	7.69 a	11.27 a	19.04 a	24.89 a	8.02 a	11.55 a	20.8 a	27.25 a	10.45 a	15.24 a	25.31 a	33.74 a
	16	4.24 a	7.51 a	11.09 a	18.83 a	24.68 a	7.83 a	11.37 a	20.59 a	27.03 a	10.26 a	15.05 a	25.09 a	33.51 a
	24	3.86 a	7.16 a	10.72 a	18.42 a	24.25 a	7.46 a	11 a	20.17 a	26.6 a	9.87 a	14.65 a	24.65 a	33.05 a
9	12	4.26 a	7.51 a	11.08 a	18.8 a	24.58 a	7.83 a	11.34 a	20.49 a	26.9 a	10.22 a	14.99 a	25 a	33.33 a
	16	4.03 a	7.29 a	10.85 a	18.54 a	24.31 a	7.6 a	11.11 a	20.23 a	26.62 a	9.98 a	14.74 a	24.73 a	33.04 a
	24	3.55 a	6.85 a	10.38 a	18.02 a	23.77 a	7.13 a	10.65 a	19.7 a	26.08 a	9.49 a	14.25 a	24.17 a	32.46 a
10	12	4.08 a	7.32 a	10.87 a	18.53 a	24.22 a	7.62 a	11.11 a	20.13 a	26.48 a	9.97 a	14.7 a	24.61 a	32.86 a
	16	3.79 a	7.04 a	10.59 a	18.21 a	23.88 a	7.33 a	10.82 a	19.81 a	26.15 a	9.67 a	14.4 a	24.27 a	32.5 a
	24	3.21 a	6.5 a	10.01 a	17.57 a	23.22 a	6.76 a	10.26 a	19.17 a	25.48 a	9.07 a	13.79 a	23.59 a	31.8 a
12	12	3.66 a	6.85 a	10.36 a	17.86 a	23.3 a	7.12 a	10.54 a	19.24 a	25.46 a	9.37 a	14.02 a	23.58 a	31.74 a
	16	3.25 a	6.46 a	9.96 a	17.41 a	22.82 a	6.71 a	10.14 a	18.79 a	24.99 a	8.95 a	13.59 a	23.11 a	31.24 a
	24	2.42 a	5.69 a	9.14 a	16.51 a	21.88 a	5.9 a	9.34 a	17.89 a	24.04 a	8.11 a	12.73 a	22.15 a	30.24 a
14	12	3.17 a	6.28 a	9.66 a	16.85 a	22.09 a	6.52 a	9.85 a	18.14 a	24.17 a	8.66 a	13.19 a	22.37 a	30.13 a
	16	2.61 a	5.77 a	9.12 a	16.25 a	21.47 a	5.98 a	9.32 a	17.55 a	23.55 a	8.1 a	12.62 a	21.74 a	29.47 a
	24	1.5 a	4.74 a	8.04 a	15.06 a	20.23 a	4.9 a	8.26 a	16.36 a	22.3 a	7 a	11.49 a	20.48 a	28.16 a
16	12	2.6 a	5.63 a	8.83 a	15.62 a	20.61 a	5.83 a	9.05 a	16.86 a	22.68 a	7.87 a	12.24 a	21.02 a	28.1 a
	16	1.89 a	4.98 a	8.15 a	14.87 a	19.84 a	5.15 a	8.38 a	16.12 a	21.9 a	7.17 a	11.52 a	20.23 a	27.28 a
	24	0.47 c	3.67 b	6.79 a	13.38 a	18.28 a	3.79 a	7.05 a	14.63 a	20.34 a	5.77 a	10.09 a	18.64 a	25.65 a

See Combined Axial and Lateral Load Table Notes

## 35 psf Lateral Load

Wall Height (ft)	Spacing (in.) o.c.	362S137-(mils)				362S162-(mils)					362S200-(mils)				362S250-(mils)				
		33 ksi		50 ksi		33 ksi		50 ksi			33 ksi		50 ksi		33 ksi		50 ksi		
		33	43	54	68	33	43	54	68	97	97	33	54	68	97	43	54	68	97
8	12	0.47 b	1.08 a	2.32 a	3.35 a	0.78 b	1.49 a	3.11 a	4.32 a	6.68 a	1.07 a	2.11 a	4.05 a	6.82 a	8.36 a	2.47 a	4.65 a	6.46 a	9.59 a
	16	0.09 d	0.69 c	2.01 b	3.08 a	0.36 c	1.09 b	2.77 a	4.02 a	6.37 a	0.61 b	1.66 a	3.66 a	6.36 a	8.04 a	1.99 a	4.23 a	6.05 a	9.21 a
	24			1.39 d	2.54 c		0.28 d	2.09 c	3.4 b	5.75 a		0.76 c	2.88 b	5.46 a	7.38 a	1.02 b	3.39 a	5.23 a	8.46 a
9	12	0.16 d	0.75 c	1.97 b	2.98 a	0.43 c	1.12 b	2.69 a	3.84 a	6.03 a	0.68 c	1.68 a	3.52 a	6.08 a	7.55 a	2.02 a	4.13 a	5.74 a	8.68 a
	16		0.27 d	1.6 c	2.66 b		0.63 d	2.28 c	3.48 b	5.66 a	0.11 d	1.14 c	3.06 b	5.54 a	7.17 a	1.43 b	3.62 a	5.25 a	8.23 a
	24			0.85 e	2.01 d			1.47 d	2.75 d	4.93 b		0.04 d	2.13 d	4.46 c	6.4 a	0.24 d	2.6 c	4.28 b	7.34 a
10	12		0.4 d	1.61 c	2.58 c	0.07 e	0.7 d	2.25 c	3.34 b	5.33 a	0.27 d	1.24 c	2.98 b	5.29 a	6.7 a	1.55 b	3.57 a	5 a	7.73 a
	16			1.17 d	2.2 d		0.16 e	1.78 d	2.92 c	4.91 b		0.6 d	2.45 c	4.67 b	6.27 a	0.84 d	2.97 c	4.44 b	7.22 a
	24			0.3 e	1.45 e			0.84 e	2.08 e	4.08 d			1.38 e	3.43 d	5.39 c		1.78 d	3.33 d	6.2 b
12	12			0.9 e	1.78 e			1.37 e	2.33 d	3.93 c		0.35 e	1.9 d	3.69 d	5.01 b	0.55 d	2.33 d	3.54 c	5.83 a
	16			0.35 f	1.32 e			0.8 e	1.82 e	3.43 d			1.26 e	2.95 e	4.49 d		1.61 e	2.87 d	5.22 c
	24			0.39 f				0.81 f	2.44 e				1.48 f	3.46 e			1.08 f	1.54 e	4 d
14	12			0.26 f	1.07 f			0.62 f	1.47 e	2.76 e			0.99 e	2.35 e	3.61 d		1.27 e	2.31 e	4.22 d
	16				0.54 f				0.9 f	2.21 e			0.27 f	1.54 f	3.04 e		0.47 f	1.57 e	3.54 e
	24								1.12 f					1.91 f			0.08 f	2.19 f	
16	12				0.49 f			0.02 f	0.78 f	1.84 f			0.27 f	1.31 f	2.53 e		0.44 f	1.34 f	2.96 e
	16								0.17 f	1.26 f				0.44 f	1.92 f			0.54 f	2.23 f
	24									0.09				0.7 f					0.78 f

Wall Height (ft)	Spacing (in.) o.c.	362S300-(mils)			600S137-(mils)				600S162-(mils)					600S200-(mils)			
		50 ksi			33 ksi		50 ksi		33 ksi		50 ksi			33 ksi			
		54	68	97	33	43	54	68	97	33	43	54	68	97	118	33	43
8	12	4.73 a	6.92 a	10.83 a	1.15 a	1.91 a	3.31 a	4.55 a	7.09 a	1.79 a	2.78 a	5 a	6.86 a	10.77 a	13.59 a	2.15 a	3.55 a
	16	4.31 a	6.5 a	10.44 a	0.91 a	1.68 a	3.12 a	4.36 a	6.92 a	1.54 a	2.54 a	4.77 a	6.64 a	10.54 a	13.36 a	1.87 a	3.26 a
	24	3.49 a	5.66 a	9.67 a	0.43 a	1.21 a	2.74 a	3.99 a	6.58 a	1.04 a	2.06 a	4.3 a	6.2 a	10.08 a	12.89 a	1.32 a	2.68 a
9	12	4.21 a	6.21 a	9.96 a	0.96 a	1.72 a	3.16 a	4.4 a	6.95 a	1.58 a	2.59 a	4.81 a	6.68 a	10.58 a	13.41 a	1.92 a	3.29 a
	16	3.71 a	5.71 a	9.5 a	0.66 a	1.43 a	2.92 a	4.16 a	6.74 a	1.27 a	2.28 a	4.52 a	6.41 a	10.3 a	13.11 a	1.57 a	2.93 a
	24	2.71 c	4.7 a	8.58 a	0.05 b	0.84 a	2.44 a	3.69 a	6.31 a	0.63 a	1.67 a	3.94 a	5.85 a	9.72 a	12.52 a	0.87 a	2.21 a
10	12	3.66 a	5.49 a	8.92 a	0.75 a	1.52 a	2.99 a	4.23 a	6.8 a	1.35 a	2.36 a	4.59 a	6.49 a	10.38 a	13.2 a	1.66 a	3 a
	16	3.08 b	4.91 a	8.39 a	0.37 a	1.15 a	2.69 a	3.94 a	6.54 a	0.96 a	1.98 a	4.23 a	6.14 a	10.03 a	12.84 a	1.23 a	2.56 a
	24	1.9 d	3.74 c	7.34 a		0.43 b	2.1 a	3.36 a	6.01 a	0.18 c	1.24 a	3.51 a	5.46 a	9.32 a	12.11 a	0.38 b	1.68 a
12	12	2.6 c	4.07 b	6.82 a	0.25 c	1.04 a	2.6 a	3.85 a	6.46 a	0.82 b	1.83 a	3.99 a	5.92 a	9.91 a	12.72 a	1.07 a	2.35 a
	16	1.84 d	3.35 d	6.19 b		0.51 c	2.17 b	3.43 a	6.08 a	0.27 c	1.3 b	3.49 a	5.43 a	9.4 a	12.19 a	0.47 c	1.73 a
	24	0.32 e	1.9 e	4.93 d			1.32 d	2.59 c	5.32 a		0.24 d	2.49 c	4.47 b	8.38 a	11.14 a		0.5 c
14	12	1.52 e	2.74 d	5.03 c		0.47 d	2.14 c	3.39 a	6.05 a	0.22 d	1.22 c	3.29 b	5.14 a	9.06 a	12.15 a	0.41 c	1.61 b
	16	0.63 f	1.92 e	4.33 d			1.55 d	2.82 c	5.53 a		0.52 d	2.64 c	4.51 b	8.39 a	11.43 a		0.81 d
	24		0.28 f	2.92 e			0.39 e	1.68 d	4.5 c			1.33 e	3.26 d	7.04 c	10 b		
16	12	0.59 f	1.64 e	3.62 d			1.6 d	2.87 c	5.57 b		0.55 d	2.51 d	4.25 c	7.84 a	10.63 a		0.83 d
	16		0.75 f	2.86 e			0.84 e	2.12 d	4.9 c			1.71 e	3.49 d	7.02 c	9.76 b		
	24			1.34 f				0.63 e	3.55 e			0.13 f	1.96 e	5.39 d	8.04 d		

Wall Height (ft)	Spacing (in.) o.c.	600S200-(mils)				600S250-(mils)				600S300-(mils)				600S350-(mils)				
		50 ksi				33 ksi		50 ksi		33 ksi		50 ksi		33 ksi		50 ksi		
		54	68	97	118	33	43	54	68	97	118	54	68	97	118	54	68	97
8	12	6.64 a	9.06 a	14.55 a	18.82 a	3.88 a	6.89 a	10.15 a	17.07 a	21.93 a	7.19 a	10.35 a	18.39 a	24.04 a	9.46 a	13.91 a	22.96 a	30.49 a
	16	6.36 a	8.78 a	14.28 a	18.53 a	3.59 a	6.62 a	9.85 a	16.74 a	21.59 a	6.92 a	10.05 a	18.06 a	23.7 a	9.16 a	13.59 a	22.61 a	30.13 a
	24	5.81 a	8.22 a	13.74 a	17.97 a	2.99 a	6.07 a	9.25 a	16.09 a	20.92 a	6.36 a	9.46 a	17.42 a	23.03 a	8.58 a	12.96 a	21.92 a	29.42 a
9	12	6.33 a	8.72 a	14.15 a	18.35 a	3.62 a	6.59 a	9.78 a	16.54 a	21.31 a	6.89 a	9.98 a	17.83 a	23.39 a	9.09 a	13.46 a	22.33 a	29.56 a
	16	5.99 a	8.38 a	13.82 a	17.99 a	3.24 a	6.25 a	9.4 a	16.13 a	20.89 a	6.54 a	9.61 a	17.43 a	22.97 a	8.72 a	13.06 a	21.89 a	29.12 a
	24	5.29 a	7.68 a	13.15 a	17.29 a	2.5 a	5.57 a	8.65 a	15.32 a	20.05 a	5.85 a	8.88 a	16.62 a	22.14 a	7.99 a	12.27 a	21.03 a	28.23 a
10	12	5.99 a	8.34 a	13.69 a	17.8 a	3.32 a	6.26 a	9.36 a	15.93 a	20.59 a	6.55 a	9.57 a	17.2 a	22.66 a	8.67 a	12.96 a	21.62 a	28.52 a
	16	5.57 a	7.92 a	13.28 a	17.37 a	2.87 a	5.85 a	8.9 a	15.44 a	20.09 a	6.13 a	9.12 a	16.71 a	22.16 a	8.23 a	12.48 a	21.1 a	27.99 a
	24	4.73 a	7.08 a	12.47 a	16.51 a	1.95 a	5.01 a	7.99 a	14.46 a	19.07 a	5.29 a	8.23 a	15.73 a	21.14 a	7.34 a	11.52 a	20.05 a	26.92 a
12	12	5.2 a	7.44 a	12.57 a	16.44 a	2.66 a	5.5 a	8.39 a	14.5 a	18.89 a	5.77 a	8.67 a	15.74 a	21 a	7.75 a	11.82 a	20.06 a	26.15 a
	16	4.62 a	6.86 a	12.01 a	15.85 a	2.01 a	4.92 a	7.76 a	13.83 a	18.2 a	5.19 a	8.05 a	15.07 a	20.3 a	7.13 a	11.15 a	19.33 a	25.42 a
	24	3.46 b	5.7 a	10.89 a	14.68 a	0.73 c	3.77 b	6.5 a	12.49 a	16.81 a	4.02 a	6.81 a	13.74 a	18.91 a	5.91 a	9.83 a	17.89 a	23.98 a
14	12	4.28 a	6.39 a	11.21 a	14.77 a	1.9 a	4.66 a	7.29 a	12.85 a	16.89 a	4.89 a	7.66 a	14.09 a	19.17 a	6.71 a	10.53 a	18.13 a	23.49 a
	16	3.54 c	5.65 b	10.49 a	14.02 a	1.05 c	3.91 b	6.48 a	11.99 a	16.01 a	4.14 b	6.84 a	13.24 a	18.27 a	5.92 a	9.67 a	17.21 a	22.58 a
	24	2.07 d	4.17 d	9.07 b	12.53 a	-0.65 d	2.41 d	4.86 c	10.29 a	14.26 a	2.63 d	5.22 b	11.53 a	16.47 a	4.34 c	7.96 a	15.35 a	20.75 a
16	12	3.32 c	5.25 b	9.69 a	12.89 a	1.07 c	3.8 c	6.15 a	11.06 a	14.71 a	3.95 b	6.55 a	12.36 a	16.82 a	5.61 a	9.14 a	15.8 a	20.67 a
	16	2.43 d	4.36 c	8.83 b	12 a	0.01 d	2.86 d	5.15 c	10.03 a	13.66 a	3.02 d	5.55 b	11.32 a	15.75 a	4.65 c	8.1 a	14.69 a	19.58 a
	24	0.65 e	2.58 e	7.13 d	10.21 c	-2.11 e	0.98 e	3.16 d	7.99 c	11.57 b	1.17 e	3.54 d	9.25 c	13.6 b	2.71 d	6 c	12.48 b	17.41 a

See Combined Axial and Lateral Load Table Notes

## 35 psf Lateral Load

Wall Height (ft)	Spacing (in.) o.c.	800S137-(mils)					800S162-(mils)					800S200-(mils)						
		33 ksi		50 ksi			33 ksi		50 ksi			33 ksi		50 ksi				
		33	43	54	68	97	33	43	54	68	97	118	33	43	54	68	97	118
8	12	1.19 a*	2.01 a	3.23 a	4.42 a	6.94 a	1.76 a*	2.85 a	4.98 a	6.8 a	10.85 a	13.91 a	2.28 a*	3.97 a	7.24 a	9.77 a	15.48 a	19.93 a
	16	0.99 a*	1.85 a	3.1 a	4.29 a	6.83 a	1.51 a*	2.66 a	4.81 a	6.64 a	10.7 a	13.76 a	2.01 a*	3.77 a	7.04 a	9.57 a	15.29 a	19.74 a
	24	0.59 a*	1.53 a	2.85 a	4.05 a	6.61 a	1.03 a*	2.27 a	4.47 a	6.31 a	10.39 a	13.45 a	1.49 a*	3.37 a	6.64 a	9.19 a	14.92 a	19.35 a
9	12	1.03 a*	1.88 a	3.13 a	4.32 a	6.85 a	1.56 a*	2.7 a	4.85 a	6.67 a	10.73 a	13.79 a	2.07 a*	3.81 a	7.08 a	9.61 a	15.33 a	19.78 a
	16	0.77 a*	1.68 a	2.97 a	4.16 a	6.71 a	1.25 a*	2.45 a	4.63 a	6.46 a	10.54 a	13.6 a	1.74 a*	3.55 a	6.83 a	9.37 a	15.09 a	19.53 a
	24	0.27 a*	1.27 a	2.64 a	3.85 a	6.43 a	0.64 a*	1.96 a	4.2 a	6.04 a	10.15 a	13.21 a	1.07 a*	3.04 a	6.33 a	8.88 a	14.62 a	19.04 a
10	12	0.85 a*	1.74 a	3.01 a	4.21 a	6.76 a	1.35 a*	2.52 a	4.7 a	6.53 a	10.6 a	13.66 a	1.83 a*	3.63 a	6.9 a	9.44 a	15.16 a	19.6 a
	16	0.54 a*	1.49 a	2.81 a	4.01 a	6.58 a	0.97 a*	2.22 a	4.43 a	6.27 a	10.36 a	13.42 a	1.42 a*	3.32 a	6.59 a	9.14 a	14.87 a	19.3 a
	24	0.98 a		2.41 a	3.63 a	6.23 a	0.21 a*	1.61 a	3.9 a	5.75 a	9.88 a	12.94 a	0.6 a*	2.69 a	5.98 a	8.53 a	14.29 a	18.69 a
12	12	0.44 a*	1.41 a	2.75 a	3.95 a	6.53 a	0.84 a*	2.12 a	4.34 a	6.18 a	10.28 a	13.34 a	1.29 a*	3.21 a	6.49 a	9.04 a	14.78 a	19.2 a
	16		1.04 a	2.46 a	3.68 a	6.28 a	0.3 a*	1.69 a	3.96 a	5.81 a	9.93 a	12.99 a	0.7 a*	2.75 a	6.05 a	8.6 a	14.36 a	18.76 a
	24		0.32 a	1.89 a	3.12 a	5.77 a		0.81 a	3.19 a	5.06 a	9.25 a	12.3 a		1.85 a	5.16 a	7.72 a	13.52 a	17.88 a
14	12		1.01 a	2.44 a	3.65 a	6.25 a	0.25 a*	1.65 a	3.93 a	5.78 a	9.91 a	12.97 a	0.64 a*	2.67 a	5.87 a	8.41 a	14.24 a	18.72 a
	16		0.52 b	2.05 a	3.27 a	5.91 a		1.05 a	3.41 a	5.27 a	9.44 a	12.5 a		2.07 a	5.28 a	7.82 a	13.67 a	18.13 a
	24			1.26 c	2.52 a	5.23 a			2.36 b	4.26 a	8.5 a	11.56 a		0.86 b	4.1 a	6.65 a	12.54 a	16.93 a
16	12		0.56 b	2.08 a	3.31 a	5.94 a		1.1 b	3.45 a	5.31 a	9.47 a	12.53 a		2.07 a	5.14 a	7.6 a	13.25 a	17.65 a
	16			1.57 c	2.81 a	5.5 a		0.32 c	2.77 b	4.65 a	8.86 a	11.92 a		1.3 b	4.4 a	6.86 a	12.54 a	16.89 a
	24			0.55 d	1.83 c	4.61 b			1.4 d	3.32 c	7.64 a	10.69 a			2.91 c	5.38 b	11.1 a	15.38 a

Wall Height (ft)	Spacing (in.) o.c.	800S250-(mils)				800S300-(mils)				800S350-(mils)				
		33 ksi		50 ksi		33 ksi		50 ksi		33 ksi		50 ksi		
		43	54	68	97	118	54	68	97	118	54	68	97	118
8	12	4.33 a	7.6 a	11.18 a	18.93 a	24.79 a	7.93 a	11.46 a	20.69 a	27.14 a	10.35 a	15.14 a	25.2 a	33.63 a
	16	4.11 a	7.39 a	10.96 a	18.7 a	24.53 a	7.71 a	11.24 a	20.45 a	26.89 a	10.13 a	14.91 a	24.94 a	33.36 a
	24	3.68 a	6.98 a	10.53 a	18.22 a	24.03 a	7.28 a	10.82 a	19.96 a	26.38 a	9.68 a	14.46 a	24.43 a	32.82 a
9	12	4.15 a	7.4 a	10.97 a	18.67 a	24.45 a	7.71 a	11.23 a	20.36 a	26.76 a	10.11 a	14.87 a	24.86 a	33.19 a
	16	3.87 a	7.14 a	10.7 a	18.37 a	24.13 a	7.44 a	10.96 a	20.05 a	26.44 a	9.82 a	14.58 a	24.54 a	32.85 a
	24	3.32 a	6.62 a	10.15 a	17.76 a	23.49 a	6.9 a	10.42 a	19.44 a	25.8 a	9.25 a	14 a	23.89 a	32.18 a
10	12	3.94 a	7.18 a	10.73 a	18.37 a	24.05 a	7.47 a	10.96 a	19.97 a	26.32 a	9.82 a	14.55 a	24.44 a	32.68 a
	16	3.6 a	6.86 a	10.39 a	18 a	23.66 a	7.14 a	10.64 a	19.59 a	25.92 a	9.47 a	14.2 a	24.04 a	32.27 a
	24	2.92 a	6.22 a	9.72 a	17.25 a	22.88 a	6.47 a	9.98 a	18.84 a	25.14 a	8.78 a	13.49 a	23.25 a	31.44 a
12	12	3.46 a	6.66 a	10.16 a	17.64 a	23.06 a	6.91 a	10.34 a	19.02 a	25.22 a	9.16 a	13.8 a	23.35 a	31.49 a
	16	2.97 a	6.2 a	9.68 a	17.11 a	22.51 a	6.44 a	9.87 a	18.49 a	24.67 a	8.67 a	13.3 a	22.79 a	30.91 a
	24	2 a	5.3 a	8.73 a	16.05 a	21.41 a	5.5 a	8.94 a	17.44 a	23.57 a	7.69 a	12.31 a	21.67 a	29.75 a
14	12	2.89 a	6.03 a	9.39 a	16.55 a	21.78 a	6.25 a	9.58 a	17.85 a	23.86 a	8.38 a	12.9 a	22.06 a	29.8 a
	16	2.24 a	5.42 a	8.76 a	15.86 a	21.05 a	5.62 a	8.97 a	17.15 a	23.14 a	7.73 a	12.24 a	21.32 a	29.03 a
	24	0.94 b	4.22 a	7.5 a	14.46 a	19.61 a	4.37 a	7.73 a	15.77 a	21.68 a	6.44 a	10.92 a	19.85 a	27.5 a
16	12	2.25 a	5.3 a	8.49 a	15.24 a	20.22 a	5.49 a	8.72 a	16.49 a	22.29 a	7.52 a	11.88 a	20.62 a	27.69 a
	16	1.42 b	4.54 a	7.7 a	14.37 a	19.32 a	4.7 a	7.94 a	15.63 a	21.38 a	6.7 a	11.05 a	19.7 a	26.74 a
	24	-0.24 d	3.02 c	6.11 a	12.63 a	17.5 a	3.11 b	6.38 a	13.89 a	19.55 a	5.07 a	9.38 a	17.84 a	24.84 a

See Combined Axial and Lateral Load Table Notes

## 40 psf Lateral Load

Wall Height (ft)	Spacing (in.) o.c.	362S137-(mils)				362S162-(mils)					362S200-(mils)				362S250-(mils)				
		33 ksi		50 ksi		33 ksi		50 ksi			33 ksi		50 ksi		33 ksi		50 ksi		
		33	43	54	68	33	43	54	68	97	97	33	54	68	97	43	54	68	97
8	12	0.31 c	0.92 b	2.18 a	3.24 a	0.6 b	1.31 a	2.96 a	4.19 a	6.55 a	0.87 b	1.92 a	3.88 a	6.62 a	8.22 a	2.26 a	4.47 a	6.29 a	9.43 a
	16		0.47 c	1.83 b	2.93 a	0.12 d	0.86 c	2.57 b	3.84 a	6.2 a	0.35 c	1.4 b	3.44 a	6.1 a	7.85 a	1.71 a	3.99 a	5.81 a	9 a
	24			1.12 d	2.31 c		-0.06 d	1.8 d	3.14 c	5.49 a		0.38 d	2.55 c	5.07 b	7.1 a	0.6 c	3.03 b	4.87 a	8.13 a
9	12		0.55 d	1.81 c	2.84 b	0.21 d	0.91 c	2.51 b	3.69 a	5.87 a	0.44 c	1.45 b	3.32 a	5.85 a	7.39 a	1.77 a	3.91 a	5.53 a	8.49 a
	16			1.38 d	2.47 c		0.35 d	2.05 c	3.27 b	5.45 a		0.82 c	2.8 c	5.23 a	6.95 a	1.09 c	3.33 b	4.98 a	7.98 a
	24			0.53 e	1.73 e			1.12 e	2.43 d	4.61 c			1.74 d	4 c	6.07 b		2.16 d	3.86 c	6.95 a
10	12		0.16 e	1.42 d	2.42 c	0.47 d	2.05 c	3.16 b	5.15 a		0.96 d	2.75 c	5.02 b	6.52 a	1.25 c	3.31 b	4.76 a	7.51 a	
	16			0.93 e	1.99 d			1.51 d	2.68 d	4.68 b		0.23 e	2.14 d	4.31 c	6.02 a	0.43 d	2.63 c	4.12 b	6.93 a
	24				1.13 e			0.43 e	1.72 e	3.72 d			0.92 e	2.9 e	5.02 c		1.27 e	2.85 d	5.76 c
12	12			0.66 e	1.58 e			1.12 e	2.11 e	3.72 d			1.62 e	3.37 d	4.79 c	0.16 e	2.02 d	3.25 c	5.56 b
	16			0.04 f	1.05 f			0.47 f	1.53 e	3.15 e			0.89 e	2.53 e	4.2 d		1.2 e	2.49 d	4.87 c
	24							0.38 f	2.02 f				0.85 f	3.02 e			0.97 e	3.48 e	
14	12				0.84 f			0.35 f	1.22 f	2.53 e			0.68 f	2 e	3.37 e		0.93 e	1.99 e	3.93 d
	16				0.24 f				0.58 f	1.9 f				1.07 f	2.72 e		0.01 f	1.14 f	3.16 e
	24									0.65 f					1.42 f				1.61 f
16	12				0.24 f					1.59 f				0.94 f	2.27 f		0.07 f	1 f	2.65 e
	16									0.92 f					1.57 f			0.08 f	1.82 f
	24													0.18					0.16 f

Wall Height (ft)	Spacing (in.) o.c.	362S300-(mils)			600S137-(mils)					600S162-(mils)					600S200-(mils)		
		50 ksi			33 ksi		50 ksi			33 ksi		50 ksi			33 ksi		
		54	68	97	33	43	54	68	97	33	43	54	68	97	118	33	43
8	12	4.55 a	6.74 a	10.66 a	1.05 a	1.81 a	3.23 a	4.47 a	7.02 a	1.68 a	2.68 a	4.9 a	6.76 a	10.67 a	13.49 a	2.03 a	3.42 a
	16	4.08 a	6.26 a	10.22 a	0.78 a	1.54 a	3.01 a	4.25 a	6.82 a	1.4 a	2.4 a	4.64 a	6.51 a	10.41 a	13.23 a	1.72 a	3.1 a
	24	3.13 b	5.3 a	9.34 a	0.22 a	1.01 a	2.58 a	3.83 a	6.44 a	0.82 a	1.85 a	4.11 a	6.01 a	9.89 a	12.69 a	1.08 a	2.44 a
9	12	3.99 a	6 a	9.77 a	0.83 a	1.6 a	3.05 a	4.3 a	6.86 a	1.45 a	2.46 a	4.69 a	6.56 a	10.46 a	13.28 a	1.77 a	3.14 a
	16	3.42 a	5.42 a	9.24 a	0.48 a	1.26 a	2.78 a	4.03 a	6.62 a	1.08 a	2.11 a	4.35 a	6.25 a	10.13 a	12.94 a	1.37 a	2.72 a
	24	2.28 c	4.27 b	8.18 a		0.59 a	2.23 a	3.49 a	6.13 a	0.36 b	1.41 a	3.69 a	5.61 a	9.47 a	12.27 a	0.57 a	1.9 a
10	12	3.41 a	5.24 a	8.7 a	0.59 a	1.36 a	2.86 a	4.11 a	6.69 a	1.18 a	2.2 a	4.44 a	6.34 a	10.23 a	13.04 a	1.48 a	2.81 a
	16	2.74 c	4.57 b	8.09 a	0.16 b	0.95 a	2.52 a	3.77 a	6.39 a	0.74 a	1.77 a	4.03 a	5.95 a	9.82 a	12.63 a	0.99 a	2.31 a
	24	1.4 d	3.24 d	6.88 b		0.12 c	1.85 b	3.11 a	5.79 a		0.92 b	3.21 a	5.17 a	9.01 a	11.79 a	0.01 c	1.3 a
12	12	2.27 d	3.76 c	6.55 a	0.02 c	0.81 b	2.41 a	3.67 a	6.29 a	0.58 c	1.6 a	3.78 a	5.71 a	9.69 a	12.49 a	0.81 b	2.09 a
	16	1.4 e	2.93 d	5.83 c		0.22 c	1.93 b	3.19 a	5.86 a		1 c	3.2 b	5.16 a	9.11 a	11.89 a	0.13 c	1.38 b
	24		1.28 e	4.39 d			0.95 d	2.23 c	4.99 b			2.06 d	4.05 c	7.94 a	10.69 a		
14	12	1.14 e	2.39 e	4.73 d		0.17 d	1.89 c	3.15 b	5.82 a		0.92 d	3.01 c	4.87 a	8.77 a	11.84 a	0.07 d	1.27 c
	16	0.13 f	1.45 e	3.92 e			1.22 d	2.49 d	5.23 b		0.12 e	2.26 d	4.15 c	8 a	11.03 a		0.35 d
	24			2.31 f				1.19 e	4.06 d			0.77 e	2.72 d	6.46 c	9.39 c		
16	12	0.18 f	1.26 f	3.29 e			1.28 e	2.55 d	5.28 c		0.18 e	2.17 d	3.92 c	7.49 b	10.26 a		0.4 d
	16		0.25 f	2.43 f			0.41 e	1.69 e	4.51 d			1.26 e	3.05 d	6.56 c	9.27 c		
	24			0.69 f					2.97 e				1.3 e	4.69 e	7.3 d		

Wall Height (ft)	Spacing (in.) o.c.	600S200-(mils)				600S250-(mils)					600S300-(mils)				600S350-(mils)			
		50 ksi				33 ksi		50 ksi			33 ksi		50 ksi		33 ksi		50 ksi	
		54	68	97	118	33	43	54	68	97	118	54	68	97	118	54	68	97
8	12	6.52 a	8.94 a	14.43 a	18.69 a	3.76 a	6.77 a	10.02 a	16.93 a	21.79 a	7.07 a	10.22 a	18.25 a	23.89 a	9.33 a	13.77 a	22.81 a	30.34 a
	16	6.2 a	8.62 a	14.13 a	18.37 a	3.42 a	6.46 a	9.68 a	16.55 a	21.4 a	6.76 a	9.89 a	17.88 a	23.51 a	8.99 a	13.41 a	22.41 a	29.93 a
	24	5.57 a	7.99 a	13.51 a	17.73 a	2.73 a	5.83 a	8.99 a	15.81 a	20.63 a	6.13 a	9.21 a	17.14 a	22.74 a	8.32 a	12.69 a	21.62 a	29.11 a
9	12	6.19 a	8.58 a	14.01 a	18.2 a	3.46 a	6.45 a	9.61 a	16.36 a	21.13 a	6.74 a	9.82 a	17.66 a	23.21 a	8.93 a	13.29 a	22.14 a	29.37 a
	16	5.79 a	8.18 a	13.62 a	17.79 a	3.03 a	6.06 a	9.18 a	15.9 a	20.65 a	6.34 a	9.4 a	17.2 a	22.73 a	8.51 a	12.84 a	21.65 a	28.87 a
	24	5 a	7.38 a	12.86 a	16.99 a	2.18 a	5.27 a	8.33 a	14.97 a	19.69 a	5.55 a	8.56 a	16.27 a	21.78 a	7.67 a	11.93 a	20.66 a	27.85 a
10	12	5.81 a	8.16 a	13.51 a	17.61 a	3.13 a	6.08 a	9.16 a	15.72 a	20.38 a	6.37 a	9.38 a	16.99 a	22.45 a	8.48 a	12.75 a	21.4 a	28.29 a
	16	5.33 a	7.68 a	13.05 a	17.12 a	2.61 a	5.61 a	8.64 a	15.16 a	19.8 a	5.89 a	8.87 a	16.43 a	21.87 a	7.98 a	12.2 a	20.8 a	27.68 a
	24	4.37 a	6.72 a	12.12 a	16.15 a	1.56 a	4.66 a	7.59 a	14.03 a	18.64 a	4.93 a	7.84 a	15.31 a	20.71 a	6.96 a	11.11 a	19.6 a	26.46 a
12	12	4.95 a	7.2 a	12.33 a	16.19 a	2.38 a	5.25 a	8.12 a	14.22 a	18.59 a	5.52 a	8.41 a	15.45 a	20.7 a	7.49 a	11.53 a	19.75 a	25.84 a
	16	4.29 a	6.53 a	11.69 a	15.52 a	1.64 a	4.59 a	7.4 a	13.45 a	17.8 a	4.85 a	7.69 a	14.69 a	19.9 a	6.78 a	10.78 a	18.92 a	25.01 a
	24	2.96 c	5.2 b	10.41 a	14.17 a	0.17 c	3.27 b	5.96 a	11.91 a	16.22 a	3.52 b	6.27 a	13.16 a	18.31 a	5.38 a	9.26 a	17.27 a	23.36 a
14	12	3.97 b	6.08 a	10.9 a	14.45 a	1.53 b	4.34 a	6.95 a	12.48 a	16.51 a	4.57 a	7.31 a	13.72 a	18.78 a	6.37 a	10.16 a	17.74 a	23.1 a
	16	3.12 c	5.23 b	10.09 a	13.6 a	0.56 d	3.48 c	6.02 a	11.5 a	15.51 a	3.71 b	6.38 a	12.75 a	17.76 a	5.47 a	9.19 a	16.68 a	22.05 a
	24	1.43 e	3.53 d	8.46 c	11.89 b		1.76 d	4.16 c	9.55 b	13.51 a	1.98 d	4.53 c	10.8 a	15.7 a	3.66 c	7.23 b	14.56 a	19.97 a
16	12	2.94 d	4.87 c	9.32 a	12.51 a	0.62 d	3.39 c	5.72 b	10.62 a	14.26 a	3.56 c	6.12 b	11.91 a	16.36 a	5.2 b	8.7 a	15.32 a	20.21 a
	16	1.92 e	3.85 d	8.35 c	11.49 b		2.32 d	4.58 c	9.45 b	13.06 a	2.49 d	4.98 c	10.73 a	15.13 a	4.09 c	7.5 b	14.06 a	18.96 a
	24		1.82 e	6.39 d	9.45 d		0.18 e	2.31 e	7.12 d	10.67 c	0.37 e	2.68 e	8.37 c	12.67 b	1.88 e	5.1 d	11.53 c	16.48 b

See Combined Axial and Lateral Load Table Notes

## 40 psf Lateral Load

Wall Height (ft)	Spacing (in.) o.c.	800S137-(mils)					800S162-(mils)					800S200-(mils)						
		33 ksi		50 ksi			33 ksi		50 ksi			33 ksi		50 ksi				
		33	43	54	68	97	33	43	54	68	97	118	33	43	54	68	97	118
8	12	1.1 a*	1.94 a	3.17 a	4.36 a	6.9 a	1.65 a*	2.77 a	4.91 a	6.73 a	10.79 a	13.85 a	2.16 a*	3.88 a	7.15 a	9.69 a	15.4 a	19.85 a
	16	0.87 a*	1.76 a	3.03 a	4.22 a	6.77 a	1.37 a*	2.55 a	4.72 a	6.54 a	10.61 a	13.67 a	1.86 a*	3.65 a	6.93 a	9.46 a	15.18 a	19.63 a
	24	0.42 a*	1.39 a	2.74 a	3.94 a	6.51 a	0.82 a*	2.1 a	4.33 a	6.17 a	10.26 a	13.32 a	1.26 a*	3.19 a	6.48 a	9.02 a	14.76 a	19.18 a
9	12	0.92 a*	1.8 a	3.06 a	4.25 a	6.79 a	1.43 a*	2.59 a	4.76 a	6.58 a	10.65 a	13.71 a	1.93 a*	3.7 a	6.97 a	9.51 a	15.23 a	19.67 a
	16	0.63 a*	1.56 a	2.87 a	4.07 a	6.63 a	1.08 a*	2.31 a	4.51 a	6.34 a	10.43 a	13.49 a	1.55 a*	3.41 a	6.69 a	9.23 a	14.96 a	19.39 a
	24	0.05 a*	1.09 a	2.5 a	3.72 a	6.31 a	0.38 a*	1.75 a	4.02 a	5.86 a	9.98 a	13.04 a	0.78 a*	2.83 a	6.12 a	8.66 a	14.42 a	18.82 a
10	12	0.72 a*	1.63 a	2.93 a	4.12 a	6.68 a	1.18 a*	2.39 a	4.58 a	6.41 a	10.49 a	13.55 a	1.66 a*	3.49 a	6.77 a	9.31 a	15.04 a	19.47 a
	16	0.36 a*	1.34 a	2.7 a	3.9 a	6.48 a	0.75 a*	2.05 a	4.28 a	6.12 a	10.22 a	13.28 a	1.19 a*	3.14 a	6.42 a	8.96 a	14.7 a	19.12 a
	24	0.77 a		2.24 a	3.46 a	6.08 a		1.35 a	3.67 a	5.53 a	9.67 a	12.73 a	0.25 a*	2.42 a	5.71 a	8.27 a	14.04 a	18.43 a
12	12	0.24 a*	1.25 a	2.63 a	3.83 a	6.42 a	0.61 a*	1.94 a	4.18 a	6.02 a	10.13 a	13.19 a	1.03 a*	3.01 a	6.3 a	8.85 a	14.6 a	19.01 a
	16		0.84 a	2.3 a	3.52 a	6.13 a		1.44 a	3.74 a	5.6 a	9.74 a	12.8 a	0.36 a*	2.5 a	5.79 a	8.35 a	14.12 a	18.51 a
	24		0.01 b	1.64 a	2.88 a	5.56 a		0.43 a	2.86 a	4.74 a	8.95 a	12.01 a		1.46 a	4.78 a	7.35 a	13.16 a	17.51 a
14	12		0.8 a	2.27 a	3.49 a	6.11 a		1.39 a	3.7 a	5.56 a	9.7 a	12.76 a	0.3 a*	2.42 a	5.62 a	8.15 a	14 a	18.47 a
	16		0.24 b	1.82 a	3.06 a	5.72 a		0.71 b	3.11 a	4.98 a	9.17 a	12.23 a		1.72 a	4.94 a	7.49 a	13.35 a	17.78 a
	24			0.93 c	2.2 b	4.94 a			1.91 c	3.82 a	8.1 a	11.15 a		0.34 c	3.59 b	6.15 a	12.05 a	16.42 a
16	12		0.28 c	1.86 b	3.09 a	5.75 a		0.77 b	3.16 a	5.03 a	9.21 a	12.27 a		1.74 a	4.82 a	7.28 a	12.94 a	17.33 a
	16			1.28 c	2.53 b	5.24 a			2.38 c	4.27 a	8.51 a	11.57 a		0.86 c	3.97 b	6.44 a	12.13 a	16.46 a
	24			0.11 e	1.4 d	4.22 c			0.82 d	2.75 c	7.11 b	10.17 a			2.27 d	4.75 c	10.49 a	14.73 a

Wall Height (ft)	Spacing (in.) o.c.	800S250-(mils)				800S300-(mils)				800S350-(mils)				
		33 ksi		50 ksi		33 ksi		50 ksi		33 ksi		50 ksi		
		43	54	68	97	118	54	68	97	118	54	68	97	118
8	12	4.24 a	7.51 a	11.09 a	18.83 a	24.68 a	7.83 a	11.37 a	20.59 a	27.03 a	10.26 a	15.05 a	25.09 a	33.51 a
	16	3.99 a	7.27 a	10.84 a	18.56 a	24.39 a	7.59 a	11.12 a	20.31 a	26.74 a	10 a	14.78 a	24.8 a	33.21 a
	24	3.49 a	6.8 a	10.34 a	18.01 a	23.81 a	7.09 a	10.63 a	19.75 a	26.16 a	9.48 a	14.26 a	24.21 a	32.59 a
9	12	4.03 a	7.29 a	10.85 a	18.54 a	24.31 a	7.6 a	11.11 a	20.23 a	26.62 a	9.98 a	14.74 a	24.73 a	33.04 a
	16	3.71 a	6.99 a	10.54 a	18.2 a	23.95 a	7.29 a	10.8 a	19.88 a	26.26 a	9.66 a	14.41 a	24.36 a	32.66 a
	24	3.08 a	6.4 a	9.92 a	17.5 a	23.22 a	6.67 a	10.19 a	19.18 a	25.53 a	9.01 a	13.75 a	23.62 a	31.89 a
10	12	3.79 a	7.04 a	10.59 a	18.21 a	23.88 a	7.33 a	10.82 a	19.81 a	26.15 a	9.67 a	14.4 a	24.27 a	32.5 a
	16	3.4 a	6.68 a	10.2 a	17.78 a	23.44 a	6.95 a	10.45 a	19.38 a	25.7 a	9.27 a	13.99 a	23.82 a	32.03 a
	24	2.63 a	5.95 a	9.44 a	16.94 a	22.55 a	6.19 a	9.7 a	18.52 a	24.81 a	8.48 a	13.19 a	22.91 a	31.09 a
12	12	3.25 a	6.46 a	9.96 a	17.41 a	22.82 a	6.71 a	10.14 a	18.79 a	24.99 a	8.95 a	13.59 a	23.11 a	31.24 a
	16	2.7 a	5.95 a	9.41 a	16.81 a	22.2 a	6.17 a	9.61 a	18.19 a	24.36 a	8.39 a	13.02 a	22.47 a	30.58 a
	24	1.59 a	4.91 a	8.32 a	15.6 a	20.94 a	5.09 a	8.54 a	16.99 a	23.1 a	7.27 a	11.88 a	21.2 a	29.25 a
14	12	2.61 a	5.77 a	9.12 a	16.25 a	21.47 a	5.98 a	9.32 a	17.55 a	23.55 a	8.1 a	12.62 a	21.74 a	29.47 a
	16	1.87 a	5.08 a	8.4 a	15.46 a	20.64 a	5.26 a	8.61 a	16.76 a	22.72 a	7.37 a	11.87 a	20.9 a	28.6 a
	24	0.39 b	3.7 a	6.96 a	13.87 a	18.98 a	3.83 a	7.2 a	15.17 a	21.06 a	5.89 a	10.35 a	19.22 a	26.85 a
16	12	1.89 a	4.98 a	8.15 a	14.87 a	19.84 a	5.15 a	8.38 a	16.12 a	21.9 a	7.17 a	11.52 a	20.23 a	27.28 a
	16	0.94 b	4.11 a	7.24 a	13.87 a	18.8 a	4.25 a	7.49 a	15.13 a	20.86 a	6.24 a	10.57 a	19.17 a	26.19 a
	24		2.36 c	5.43 b	11.88 a	16.73 a	2.44 c	5.71 b	13.15 a	18.77 a	4.37 b	8.66 a	17.05 a	24.02 a

See Combined Axial and Lateral Load Table Notes

## 50 psf Lateral Load

Wall Height (ft)	Spacing (in.) o.c.	362S137-(mils)				362S162-(mils)					362S200-(mils)				362S250-(mils)				
		33 ksi		50 ksi		33 ksi		50 ksi			33 ksi		50 ksi		33 ksi		50 ksi		
		33	43	54	68	33	43	54	68	97	97	33	54	68	97	43	54	68	97
8	12		0.58 c	1.92 b	3 a	0.24 c	0.97 b	2.67 a	3.93 a	6.28 a	0.48 c	1.53 a	3.55 a	6.23 a	7.94 a	1.85 a	4.11 a	5.93 a	9.11 a
	16		0.03 d	1.47 c	2.62 b		0.4 d	2.18 c	3.49 b	5.84 a		0.89 c	3 b	5.59 a	7.48 a	1.15 b	3.51 a	5.34 a	8.56 a
	24			0.59 e	1.84 d			1.21 d	2.62 d	4.96 b			1.89 d	4.29 c	6.54 a		2.31 c	4.17 b	7.48 a
9	12		0.14 d	1.49 d	2.56 c		0.49 d	2.16 c	3.37 b	5.56 a		0.98 c	2.93 b	5.39 a	7.06 a	1.26 b	3.47 a	5.11 a	8.1 a
	16			0.96 e	2.1 d			1.58 d	2.85 c	5.03 b		0.2 d	2.27 d	4.61 c	6.51 a	0.41 d	2.74 c	4.42 b	7.46 a
	24				1.17 e			0.42 e	1.81 e	3.99 d			0.94 e	3.07 d	5.41 c		1.29 d	3.02 d	6.18 b
10	12			1.05 e	2.1 d			1.65 d	2.8 c	4.8 b		0.41 d	2.29 d	4.49 c	6.14 a	0.64 d	2.8 c	4.28 b	7.07 a
	16			0.43 e	1.56 e			0.97 e	2.2 d	4.2 c			1.53 e	3.6 d	5.52 c		1.95 d	3.49 c	6.34 b
	24				0.48 f				1 e	3 e			0.01 f	1.83 e	4.27 d		0.25 e	1.89 e	4.88 d
12	12			0.2 f	1.19 e			0.63 f	1.68 e	3.29 d			1.07 e	2.74 e	4.35 d		1.4 e	2.68 d	5.04 c
	16				0.52 f				0.95 f	2.59 e			0.16 f	1.69 e	3.61 e		0.38 f	1.73 e	4.18 d
	24									1.17 f				2.14 f					2.44 e
14	12				0.39 f				0.74 f	2.06 f			0.07 f	1.3 f	2.88 e		0.24 f	1.35 e	3.35 e
	16									1.27 f				0.14 f	2.07 f			0.29 f	2.38 e
	24														0.44 f				0.46 f
16	12									1.09 f				0.19 f	1.74 f			0.31 f	2.02 f
	16									0.26					0.88 f				0.99 f
	24																		

Wall Height (ft)	Spacing (in.) o.c.	362S300-(mils)			600S137-(mils)					600S162-(mils)					600S200-(mils)		
		50 ksi			33 ksi		50 ksi			33 ksi		50 ksi			33 ksi		
		54	68	97	33	43	54	68	97	33	43	54	68	97	118	33	43
8	12	4.55 a	6.74 a	10.66 a	1.05 a	1.81 a	3.23 a	4.47 a	7.02 a	1.68 a	2.68 a	4.9 a	6.76 a	10.67 a	13.49 a	2.03 a	3.42 a
	16	4.08 a	6.26 a	10.22 a	0.78 a	1.54 a	3.01 a	4.25 a	6.82 a	1.4 a	2.4 a	4.64 a	6.51 a	10.41 a	13.23 a	1.72 a	3.1 a
	24	3.13 b	5.3 a	9.34 a	0.22 a	1.01 a	2.58 a	3.83 a	6.44 a	0.82 a	1.85 a	4.11 a	6.01 a	9.89 a	12.69 a	1.08 a	2.44 a
9	12	3.99 a	6 a	9.77 a	0.83 a	1.6 a	3.05 a	4.3 a	6.86 a	1.45 a	2.46 a	4.69 a	6.56 a	10.46 a	13.28 a	1.77 a	3.14 a
	16	3.42 a	5.42 a	9.24 a	0.48 a	1.26 a	2.78 a	4.03 a	6.62 a	1.08 a	2.11 a	4.35 a	6.25 a	10.13 a	12.94 a	1.37 a	2.72 a
	24	2.28 c	4.27 b	8.18 a		0.59 a	2.23 a	3.49 a	6.13 a	0.36 b	1.41 a	3.69 a	5.61 a	9.47 a	12.27 a	0.57 a	1.9 a
10	12	3.41 a	5.24 a	8.7 a	0.59 a	1.36 a	2.86 a	4.11 a	6.69 a	1.18 a	2.2 a	4.44 a	6.34 a	10.23 a	13.04 a	1.48 a	2.81 a
	16	2.74 c	4.57 b	8.09 a	0.16 b	0.95 a	2.52 a	3.77 a	6.39 a	0.74 a	1.77 a	4.03 a	5.95 a	9.82 a	12.63 a	0.99 a	2.31 a
	24	1.4 d	3.24 d	6.88 b		0.12 c	1.85 b	3.11 a	5.79 a		0.92 b	3.21 a	5.17 a	9.01 a	11.79 a	0.01 c	1.3 a
12	12	2.27 d	3.76 c	6.55 a	0.02 c	0.81 b	2.41 a	3.67 a	6.29 a	0.58 c	1.6 a	3.78 a	5.71 a	9.69 a	12.49 a	0.81 b	2.09 a
	16	1.4 e	2.93 d	5.83 c		0.22 c	1.93 b	3.19 a	5.86 a		1 c	3.2 b	5.16 a	9.11 a	11.89 a	0.13 c	1.38 b
	24		1.28 e	4.39 d			0.95 d	2.23 c	4.99 b			2.06 d	4.05 c	7.94 a	10.69 a		
14	12	1.14 e	2.39 e	4.73 d		0.17 d	1.89 c	3.15 b	5.82 a		0.92 d	3.01 c	4.87 a	8.77 a	11.84 a	0.07 d	1.27 c
	16	0.13 f	1.45 e	3.92 e			1.22 d	2.49 d	5.23 b		0.12 e	2.26 d	4.15 c	8 a	11.03 a		0.35 d
	24			2.31 f				1.19 e	4.06 d			0.77 e	2.72 d	6.46 c	9.39 c		
16	12	0.18 f	1.26 f	3.29 e			1.28 e	2.55 d	5.28 c		0.18 e	2.17 d	3.92 c	7.49 b	10.26 a		0.4 d
	16		0.25 f	2.43 f			0.41 e	1.69 e	4.51 d			1.26 e	3.05 d	6.56 c	9.27 c		
	24			0.69 f					2.97 e				1.3 e	4.69 e	7.3 d		

Wall Height (ft)	Spacing (in.) o.c.	600S200-(mils)				600S250-(mils)				600S300-(mils)				600S350-(mils)				
		50 ksi				33 ksi		50 ksi		33 ksi		50 ksi		33 ksi		50 ksi		
		54	68	97	118	33	43	54	68	97	118	54	68	97	118	54	68	97
8	12	6.28 a	8.7 a	14.2 a	18.45 a	3.5 a	6.54 a	9.76 a	16.65 a	21.5 a	6.84 a	9.97 a	17.97 a	23.6 a	9.08 a	13.5 a	22.51 a	30.03 a
	16	5.88 a	8.3 a	13.82 a	18.05 a	3.08 a	6.15 a	9.33 a	16.18 a	21.02 a	6.44 a	9.55 a	17.51 a	23.12 a	8.66 a	13.05 a	22.02 a	29.52 a
	24	5.09 a	7.51 a	13.06 a	17.24 a	2.22 a	5.36 a	8.47 a	15.25 a	20.06 a	5.65 a	8.71 a	16.58 a	22.16 a	7.82 a	12.14 a	21.03 a	28.5 a
9	12	5.89 a	8.28 a	13.72 a	17.89 a	3.14 a	6.15 a	9.29 a	16.01 a	20.77 a	6.44 a	9.51 a	17.31 a	22.85 a	8.62 a	12.95 a	21.77 a	28.99 a
	16	5.39 a	7.78 a	13.24 a	17.39 a	2.6 a	5.66 a	8.76 a	15.43 a	20.17 a	5.95 a	8.98 a	16.73 a	22.25 a	8.09 a	12.39 a	21.15 a	28.36 a
	24	4.4 a	6.79 a	12.29 a	16.38 a	1.53 a	4.69 a	7.68 a	14.27 a	18.98 a	4.96 a	7.93 a	15.58 a	21.06 a	7.05 a	11.26 a	19.91 a	27.09 a
10	12	5.45 a	7.8 a	13.17 a	17.25 a	2.74 a	5.73 a	8.77 a	15.3 a	19.94 a	6.01 a	9 a	16.57 a	22.01 a	8.1 a	12.34 a	20.95 a	27.83 a
	16	4.85 a	7.2 a	12.59 a	16.64 a	2.08 a	5.13 a	8.12 a	14.6 a	19.22 a	5.41 a	8.36 a	15.87 a	21.29 a	7.47 a	11.66 a	20.2 a	27.07 a
	24	3.65 a	5.99 a	11.43 a	15.41 a	0.78 b	3.94 a	6.81 a	13.19 a	17.77 a	4.2 a	7.08 a	14.48 a	19.84 a	6.2 a	10.29 a	18.7 a	25.54 a
12	12	4.45 a	6.7 a	11.85 a	15.69 a	1.83 a	4.76 a	7.58 a	13.64 a	18 a	5.02 a	7.87 a	14.88 a	20.1 a	6.96 a	10.96 a	19.13 a	25.22 a
	16	3.62 b	5.87 a	11.05 a	14.85 a	0.91 b	3.93 a	6.68 a	12.68 a	17.01 a	4.19 a	6.98 a	13.93 a	19.11 a	6.08 a	10.02 a	18.09 a	24.18 a
	24	1.97 d	4.21 c	9.45 a	13.17 a		2.28 c	4.88 b	10.76 a	15.04 a	2.52 c	5.2 b	12.02 a	17.11 a	4.33 b	8.13 a	16.03 a	22.12 a
14	12	3.33 c	5.44 b	10.29 a	13.81 a	0.81 c	3.7 b	6.25 a	11.75 a	15.76 a	3.92 b	6.61 a	12.99 a	18.01 a	5.7 a	9.43 a	16.94 a	22.32 a
	16	2.28 d	4.38 c	9.27 b	12.74 a		2.62 d	5.09 c	10.53 a	14.51 a	2.84 c	5.45 b	11.78 a	16.73 a	4.57 c	8.21 a	15.62 a	21.01 a
	24	0.16 e	2.26 e	7.24 d	10.61 c		0.47 e	2.77 d	8.09 c	12.01 b	0.68 e	3.14 d	9.34 c	14.16 a	2.31 d	5.77 c	12.97 b	18.41 a
16	12	2.17 d	4.11 d	8.59 b	11.74 a		2.59 d	4.87 c	9.74 b	13.36 a	2.76 d	5.26 c	11.03 a	15.44 a	4.37 c	7.8 b	14.37 a	19.27 a
	16	0.9 e	2.84 e	7.37 d	10.47 c		1.25 e	3.44 d	8.28 c	11.87 b	1.43 e	3.83 d	9.55 b	13.9 a	2.97 d	6.3 c	12.79 b	17.72 a
	24		0.29 f	4.93 e	7.91 d			0.6 e	5.36 e	8.88 d		0.96 e	6.59 d	10.83 c	0.22 e	3.31 e	9.63 d	14.61 c

See Combined Axial and Lateral Load Table Notes

## 50 psf Lateral Load

Wall Height (ft)	Spacing (in.) o.c.	800S137-(mils)					800S162-(mils)					800S200-(mils)						
		33 ksi		50 ksi			33 ksi		50 ksi			33 ksi		50 ksi				
		33	43	54	68	97	33	43	54	68	97	118	33	43	54	68	97	118
8	12	0.93 a*	1.8 a	3.06 a	4.26 a	6.8 a	1.44 a*	2.6 a	4.76 a	6.59 a	10.66 a	13.72 a	1.94 a*	3.71 a	6.98 a	9.52 a	15.24 a	19.68 a
	16	0.64 a*	1.57 a	2.88 a	4.08 a	6.64 a	1.1 a*	2.33 a	4.52 a	6.35 a	10.44 a	13.5 a	1.56 a*	3.42 a	6.7 a	9.24 a	14.97 a	19.4 a
	24	0.07 a*	1.11 a	2.52 a	3.73 a	6.32 a	0.4 a*	1.77 a	4.03 a	5.88 a	10 a	13.06 a	0.81 a*	2.85 a	6.14 a	8.68 a	14.44 a	18.84 a
9	12	0.7 a*	1.62 a	2.92 a	4.12 a	6.67 a	1.17 a*	2.38 a	4.57 a	6.4 a	10.48 a	13.54 a	1.64 a*	3.48 a	6.76 a	9.3 a	15.02 a	19.46 a
	16	0.34 a*	1.33 a	2.69 a	3.89 a	6.47 a	0.73 a*	2.03 a	4.26 a	6.1 a	10.21 a	13.27 a	1.16 a*	3.12 a	6.4 a	8.95 a	14.69 a	19.11 a
	24	0.74 a		2.23 a	3.45 a	6.07 a		1.33 a	3.64 a	5.5 a	9.65 a	12.71 a	0.21 a*	2.39 a	5.69 a	8.24 a	14.01 a	18.4 a
10	12	0.45 a*	1.41 a	2.76 a	3.96 a	6.53 a	0.86 a*	2.13 a	4.35 a	6.19 a	10.29 a	13.35 a	1.31 a*	3.23 a	6.51 a	9.05 a	14.79 a	19.21 a
	16		1.05 a	2.47 a	3.68 a	6.28 a	0.32 a*	1.7 a	3.97 a	5.82 a	9.95 a	13.01 a	0.72 a*	2.78 a	6.07 a	8.62 a	14.37 a	18.77 a
	24		0.33 a	1.9 a	3.13 a	5.79 a	0.83 a		3.21 a	5.08 a	9.26 a	12.32 a		1.88 a	5.18 a	7.75 a	13.54 a	17.9 a
12	12		0.94 a	2.38 a	3.6 a	6.2 a	0.14 a*	1.56 a	3.85 a	5.7 a	9.84 a	12.9 a	0.53 a*	2.63 a	5.92 a	8.48 a	14.24 a	18.64 a
	16		0.42 a	1.97 a	3.2 a	5.85 a		0.93 a	3.3 a	5.17 a	9.34 a	12.4 a		1.98 a	5.29 a	7.85 a	13.64 a	18.01 a
	24			1.15 b	2.41 a	5.13 a			2.21 a	4.1 a	8.36 a	11.42 a		0.69 b	4.02 a	6.6 a	12.44 a	16.75 a
14	12		0.38 b	1.94 a	3.17 a	5.82 a		0.88 a	3.26 a	5.13 a	9.3 a	12.36 a		1.9 a	5.11 a	7.65 a	13.51 a	17.96 a
	16			1.38 b	2.63 a	5.33 a		0.03 c	2.51 b	4.4 a	8.63 a	11.69 a		1.03 b	4.27 a	6.82 a	12.7 a	17.1 a
	24			0.26 d	1.55 c	4.36 b			1.02 d	2.95 c	7.29 a	10.35 a		2.58 c	5.14 b	11.08 a	15.39 a	
16	12			1.42 c	2.67 b	5.37 a		0.1 c	2.57 b	4.46 a	8.69 a	11.75 a		1.08 c	4.18 a	6.65 a	12.33 a	16.68 a
	16			0.69 d	1.97 c	4.73 b			1.6 d	3.51 c	7.81 a	10.87 a			3.12 c	5.59 b	11.31 a	15.59 a
	24				0.56 e	3.46 d				1.62 d	6.06 c	9.12 b			1 d	3.48 d	9.26 b	13.43 a

Wall Height (ft)	Spacing (in.) o.c.	800S250-(mils)				800S300-(mils)				800S350-(mils)				
		33 ksi		50 ksi		33 ksi		50 ksi		33 ksi		50 ksi		
		43	54	68	97	118	54	68	97	118	54	68	97	118
8	12	4.05 a	7.33 a	10.9 a	18.63 a	24.46 a	7.65 a	11.18 a	20.38 a	26.82 a	10.06 a	14.85 a	24.87 a	33.28 a
	16	3.74 a	7.04 a	10.59 a	18.28 a	24.1 a	7.34 a	10.88 a	20.03 a	26.45 a	9.74 a	14.52 a	24.5 a	32.9 a
	24	3.11 a	6.45 a	9.97 a	17.6 a	23.38 a	6.72 a	10.27 a	19.34 a	25.73 a	9.1 a	13.87 a	23.77 a	32.13 a
9	12	3.79 a	7.07 a	10.62 a	18.28 a	24.04 a	7.36 a	10.88 a	19.96 a	26.35 a	9.74 a	14.49 a	24.45 a	32.75 a
	16	3.4 a	6.7 a	10.23 a	17.85 a	23.59 a	6.98 a	10.5 a	19.53 a	25.89 a	9.33 a	14.08 a	23.99 a	32.27 a
	24	2.61 a	5.95 a	9.45 a	16.99 a	22.68 a	6.2 a	9.73 a	18.65 a	24.98 a	8.52 a	13.26 a	23.06 a	31.31 a
10	12	3.5 a	6.77 a	10.3 a	17.89 a	23.55 a	7.05 a	10.54 a	19.49 a	25.81 a	9.37 a	14.1 a	23.93 a	32.15 a
	16	3.02 a	6.31 a	9.82 a	17.36 a	22.99 a	6.57 a	10.07 a	18.95 a	25.25 a	8.88 a	13.59 a	23.36 a	31.56 a
	24	2.05 a	5.4 a	8.86 a	16.3 a	21.88 a	5.62 a	9.13 a	17.88 a	24.13 a	7.88 a	12.58 a	22.23 a	30.38 a
12	12	2.83 a	6.07 a	9.55 a	16.96 a	22.35 a	6.31 a	9.74 a	18.34 a	24.51 a	8.53 a	13.16 a	22.63 a	30.74 a
	16	2.14 a	5.43 a	8.87 a	16.2 a	21.57 a	5.63 a	9.08 a	17.59 a	23.73 a	7.83 a	12.45 a	21.83 a	29.91 a
	24	0.76 a	4.13 a	7.5 a	14.7 a	20 a	4.28 a	7.75 a	16.09 a	22.15 a	6.43 a	11.02 a	20.24 a	28.25 a
14	12	2.05 a	5.25 a	8.58 a	15.66 a	20.85 a	5.44 a	8.79 a	16.96 a	22.93 a	7.55 a	12.05 a	21.11 a	28.81 a
	16	1.13 a	4.39 a	7.68 a	14.66 a	19.81 a	4.55 a	7.91 a	15.97 a	21.89 a	6.63 a	11.11 a	20.06 a	27.72 a
	24	-0.73 c	2.67 b	5.87 a	12.67 a	17.74 a	2.76 b	6.15 a	13.99 a	19.81 a	4.78 a	9.22 a	17.96 a	25.54 a
16	12	1.18 b	4.32 a	7.47 a	14.12 a	19.06 a	4.47 a	7.72 a	15.38 a	21.12 a	6.47 a	10.81 a	19.43 a	26.47 a
	16	-0.01 c	3.23 b	6.33 a	12.88 a	17.76 a	3.34 b	6.6 a	14.14 a	19.81 a	5.3 a	9.62 a	18.11 a	25.11 a
	24	-2.38 e	1.06 d	4.06 c	10.39 b	15.17 a	1.08 d	4.38 c	11.66 a	17.21 a	2.97 c	7.23 b	15.46 a	22.39 a

See Combined Axial and Lateral Load Table Notes

## Jamb Stud

Industry standard nomenclature is used to identify MBA's products. The Steel Framing Industry Association has established standard designation codes for structural studs and track. In each case, the identification starts with the measurement of the width of the member, followed by a letter (J = jamb stud) followed by the flange dimension. A hyphen is used to separate all of this from the thickness of the metal.

### Member Depth:

(Example:  $3\text{-}5/8'' = 3.625'' = 362 \times 1/100$  inches)

All member depths are taken in 1/100 inches. For all "T" sections member depth is the inside to inside dimension.

### Flange Width:

(Example:  $1\text{-}1/4'' = 1.25'' = 125 \times 1/100$  inches)

All flange widths are taken in 1/100 inches.



### Style:

(Example: Jamb or Joist Section = J)

Relevant alpha characters utilized by the designation system are:

J = Jamb or Joist Sections

### Material Thickness:

(Example:  $0.018$  in. = 18 mils; 1 mil = 1/1000 in.)

Material thickness is the minimum base metal thickness in mils.

Minimum base metal thickness represents 95% of the design thickness.

## Steel Thickness

Mils	Gauge	Thickness (in)	
		Design	Minimum <sup>1</sup>
43	18	0.0451	0.0428
54	16	0.0566	0.0538
68	14	0.0713	0.0677
97	12	0.1017	0.0966

<sup>1</sup> Minimum Thickness represents 95% of the design thickness and is the minimum acceptable thickness delivered to the job site based on AISI S100-16/S2-20.



Section	Flange Width	Design Stiffening Lip Length (in)
JS250	2.5"	1.000
JS300	3.5"	1.000
JS350	3"	1.000

## Jamb Stud and Header Punchouts

Jamb studs and headers can be manufactured with punchouts to enable plumbing and wiring installation. The lowest punchout is centered 12" from the bottom and 24" or 48" o.c thereafter, with the final opening 12" minimum from the top. Care should be taken during installation to orient all jambs and headers in the same top-to-bottom direction.

## General Notes

- Physical properties and load tables have been calculated in conformance with the AISI S100-16/S2-20.
- Structural framing members have a protective coating conforming to ASTM C 955.
- Reference ASTM specification A 1003/A 1003 M table 1 for the universe of allowable coatings for light gauge steel framing.
- All delivered material must be kept dry, preferably by being stored inside a building under a roof. If it is necessary to store material outside, it must be stacked off the ground, properly supported on a level platform, and fully protected from the weather. Reference ASTM C 754 section 8 and ASTM C 1007 section 4.

## LEED Green Building Credits

MR Credit 2: Construction Waste Management – MBA steel framing is 100% recyclable.

MR Credit 4: Recycled Content – MBA steel framing is formed from no less than 25.5% post-consumer and 6.8% pre-consumer recycled content.

MR Credit 5: Regional Materials – MBA has manufacturing facilities in multiple states.

## Section Properties

### Section Properties Table Notes

1. Web depth for header section is equal to the nominal height plus 2 times design thickness plus the bend radius.
2. Effective properties incorporate the strength increase from the cold work of forming as applicable per the AISI S100-16/S2-20.
3. Tabulated gross properties are based on the full, unreduced section away from punchouts.
4. Effective properties of all 'J' sections based on unpunched sections.
5. For deflection calculations, use the effective moment of inertia.
6. Where effective properties are listed for a section, jamb studs at 43mils(18ga) are at 33ksi and 54mils(16ga), 68mils(14ga), and 97mils(12ga) are at 50ksi for the effective properties.

### Jamb (J) Stud Section Properties

Section	Design Thickness (in)	Gross Properties							Effective Properties				Torsional				
		Area (in <sup>2</sup> )	Weight (lb/ft)	I <sub>x</sub> (in <sup>4</sup> )	S <sub>x</sub> (in <sup>3</sup> )	R <sub>x</sub> (in)	I <sub>y</sub> (in <sup>4</sup> )	R <sub>y</sub> (in)	I <sub>x</sub> (in <sup>4</sup> )	S <sub>x</sub> (in <sup>3</sup> )	Ma (in-k)	V <sub>ag</sub> (lb)	J <sup>x1000</sup> (in <sup>4</sup> )	C <sub>w</sub> (in <sup>6</sup> )	X <sub>o</sub> (in)	R <sub>o</sub> (in)	β
362JS300-33	0.0346	0.391	1.33	0.894	0.493	1.513	0.540	1.179	0.807	0.479	7.11	2047	1.560	2.383	-2.982	3.544	0.292
362JS300-43	0.0451	0.506	1.72	1.151	0.635	1.507	0.694	1.171	1.106	0.594	10.38	3014	0.343	3.035	-2.969	3.530	0.292
362JS300-54	0.0566	0.632	2.15	1.427	0.787	1.503	0.859	1.165	1.379	0.743	19.75	5682	0.675	3.724	-2.955	3.514	0.293
362JS300-68	0.0713	0.791	2.69	1.771	0.977	1.496	1.063	1.159	1.771	0.977	26.63	7078	1.341	4.556	-2.938	3.495	0.293
362JS300-97	0.1017	1.114	3.79	2.449	1.351	1.483	1.461	1.146	2.444	1.351	40.24	9865	3.840	6.115	-2.902	3.454	0.294
362JS350-54	0.0566	0.689	2.34	1.607	0.887	1.528	1.234	1.339	1.508	0.796	20.84	6743	0.736	5.289	-3.449	4.002	0.258
362JS350-68	0.0713	0.863	2.93	1.996	1.101	1.521	1.531	1.332	1.978	1.084	27.76	8415	1.462	6.484	-3.431	3.983	0.258
362JS350-97	0.1017	1.215	4.13	2.765	1.526	1.508	2.113	1.319	2.765	1.526	41.35	11772	4.190	8.737	-3.395	3.942	0.258
600JS300-33	0.0346	0.473	1.61	2.806	0.935	2.436	0.650	1.172	2.571	0.909	13.05	2047	1.888	5.609	-2.597	3.748	0.520
600JS300-43	0.0451	0.613	2.09	3.621	1.207	2.430	0.835	1.167	3.493	1.138	20.09	3014	0.416	7.165	-2.584	3.734	0.521
600JS300-54	0.0566	0.767	2.61	4.505	1.502	2.424	1.034	1.161	4.366	1.426	38.32	5682	0.819	8.822	-2.571	3.719	0.522
600JS300-68	0.0713	0.961	3.27	5.613	1.871	2.417	1.281	1.155	5.613	1.871	51.44	7078	1.628	10.842	-2.553	3.701	0.524
600JS300-97	0.1017	1.355	4.61	7.825	2.608	2.403	1.764	1.141	7.825	2.608	77.30	9865	4.672	14.689	-2.517	3.662	0.528
600JS350-54	0.0566	0.823	2.80	5.005	1.668	2.466	1.485	1.343	4.722	1.515	40.20	6743	0.879	12.575	-3.035	4.135	0.461
600JS350-68	0.0713	1.032	3.51	6.240	2.080	2.459	1.843	1.336	6.176	2.044	53.20	8415	1.749	15.485	-3.017	4.115	0.462
600JS350-97	0.1017	1.457	4.95	8.709	2.903	2.445	2.547	1.322	8.710	2.903	78.13	11772	5.023	21.062	-2.981	4.076	0.465
800JS300-43	0.0451	0.704	2.39	7.031	1.758	3.161	0.920	1.144	6.825	1.675	28.41	3014	0.477	12.654	-2.335	4.093	0.674
800JS300-54	0.0566	0.880	2.99	8.759	2.190	3.155	1.140	1.138	8.527	2.097	54.87	5682	0.940	15.604	-2.322	4.080	0.676
800JS300-68	0.0713	1.103	3.75	10.931	2.733	3.148	1.412	1.132	10.931	2.733	75.59	7078	1.870	19.219	-2.305	4.062	0.678
800JS300-97	0.1017	1.559	5.30	15.288	3.822	3.132	1.946	1.117	15.288	3.822	113.11	9865	5.374	26.155	-2.271	4.027	0.682
800JS350-54	0.0566	0.936	3.18	9.662	2.413	3.211	1.640	1.323	9.182	2.225	56.57	6743	1.000	22.249	-2.763	4.437	0.612
800JS350-68	0.0713	1.175	3.99	12.051	3.013	3.203	2.035	1.316	11.922	2.960	77.92	8415	1.990	27.455	-2.746	4.419	0.614
800JS350-97	0.1017	1.660	5.65	16.875	4.219	3.188	2.815	1.302	16.875	4.219	113.83	11772	5.724	37.510	-2.710	4.382	0.618

## Jamb & Header System

Industry standard nomenclature is used to identify MBA's products. The Steel Framing Industry Association has established standard designation codes for structural studs and track. In each case, the identification starts with the measurement of the width of the member, followed by a letter (J = jamb stud and H = header) followed by the flange dimension. A hyphen is used to separate all of this from the thickness of the metal.

### Member Depth:

(Example:  $3\text{-}5/8'' = 3.625'' = 362 \times 1/100$  inches)

All member depths are taken in 1/100 inches. For all "T" sections member depth is the inside to inside dimension.

### Flange Width:

(Example:  $1\text{-}1/4'' = 1.25'' = 125 \times 1/100$  inches)

All flange widths are taken in 1/100 inches.

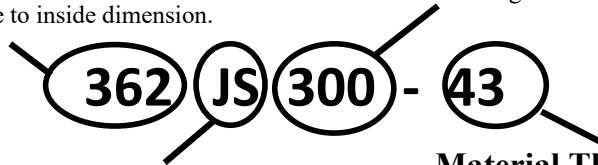

### Style:

(Example: Jamb or Joist Section = J)

Relevant alpha characters utilized by the designation system are:

**J** = Jamb or Joist Sections      **H** = Header Sections

### Material Thickness:

(Example:  $0.018$  in. = 18 mils; 1 mil = 1/100 in.)

Material thickness is the minimum base metal thickness in mils. Minimum base metal thickness represents 95% of the design thickness.

## Steel Thickness

Section	Flange Width	Design Stiffening Lip Length (in)
JS300	3"	1.000
JS350	3.5"	1.000
HS300	3"	1.000
HS350	3.5"	1.000

<sup>1</sup> Minimum Thickness represents 95% of the design thickness and is the minimum acceptable thickness delivered to the job site based on AISI S100-16/S2-20.

## Design Stiffening Lip Length

Mils	Gauge	Thickness (in)	
		Design	Minimum <sup>1</sup>
43	18	0.0451	0.0428
54	16	0.0566	0.0538
68	14	0.0713	0.0677
97	12	0.1017	0.0966

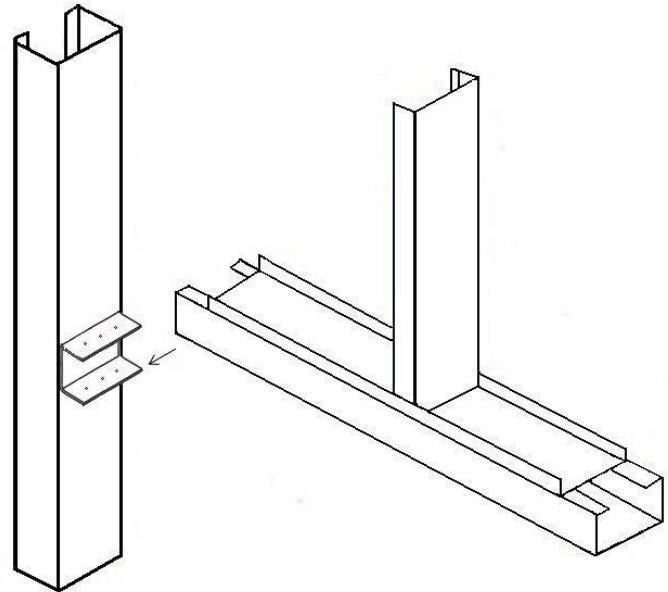

## Jamb Stud and Header Punchouts

Jamb studs and headers can be manufactured with punchouts to enable plumbing and wiring installation. The lowest punchout is centered 12" from the bottom and 24" or 48" o.c thereafter, with the final opening 12" minimum from the top. Care should be taken during installation to orient all jambs and headers in the same top-to-bottom direction.

## General Notes

- Physical properties and load tables have been calculated in conformance with the AISI S100-16/S2-20.
- Structural framing members have a protective coating conforming to ASTM C 955.
- Reference ASTM specification A 1003/A 1003 M table 1 for the universe of allowable coatings for light gauge steel framing.
- All delivered material must be kept dry, preferably by being stored inside a building under a roof. If it is necessary to store material outside, it must be stacked off the ground, properly supported on a level platform, and fully protected from the weather. Reference ASTM C 754 section 8 and ASTM C 1007 section 4.

## Section Properties

### Section Properties Table Notes

1. Web depth for header section is equal to the nominal height plus 2 times design thickness plus the bend radius.
2. Effective properties incorporate the strength increase from the cold work of forming as applicable per the AISI S100-16/S2-20.
3. Tabulated gross properties are based on the full, unreduced section away from punchouts.
4. Effective properties of all 'J' and 'H' sections based on unpunched sections.
5. For deflection calculations, use the effective moment of inertia.
6. Where effective properties are listed for a section, both the Jamb and Header at 43mils(18ga) are at 33ksi and 54mils(16ga), 68mils(14ga), and 97mils(12ga) are at 50ksi for the effective properties.

### Jamb (J) Stud Section Properties

Section	Design Thickness (in)	Gross Properties							Effective Properties				Torsional				
		Area (in <sup>2</sup> )	Weight (lb/ft)	I <sub>x</sub> (in <sup>4</sup> )	S <sub>x</sub> (in <sup>3</sup> )	R <sub>x</sub> (in)	I <sub>y</sub> (in <sup>4</sup> )	R <sub>y</sub> (in)	I <sub>x</sub> (in <sup>4</sup> )	S <sub>x</sub> (in <sup>3</sup> )	Ma (in-k)	V <sub>ag</sub> (lb)	J <sup>x1000</sup> (in <sup>4</sup> )	C <sub>w</sub> (in <sup>6</sup> )	X <sub>o</sub> (in)	R <sub>o</sub> (in)	β
362HS300-43	0.0451	0.506	1.72	1.151	0.635	1.507	0.694	1.171	1.106	0.594	10.38	3014	0.343	3.035	-2.969	3.530	0.292
362HS300-54	0.0566	0.632	2.15	1.427	0.787	1.503	0.859	1.165	1.379	0.743	19.75	5682	0.675	3.724	-2.955	3.514	0.293
800HS300-68	0.0713	1.103	3.75	10.931	2.733	3.148	1.063	1.159	1.771	0.977	26.63	7078	1.341	4.556	-2.938	3.495	0.293
362HS300-97	0.1017	1.114	3.79	2.449	1.351	1.483	1.461	1.146	2.444	1.351	40.24	9865	3.840	6.115	-2.902	3.454	0.294
362HS350-54	0.0566	0.689	2.34	1.607	0.887	1.528	1.234	1.339	1.508	0.796	20.84	6743	0.736	5.289	-3.449	4.002	0.258
362HS350-68	0.0713	0.863	2.93	1.996	1.101	1.521	1.531	1.332	1.978	1.084	27.76	8415	1.462	6.484	-3.431	3.983	0.258
362HS350-97	0.1017	1.215	4.13	2.765	1.526	1.508	2.113	1.319	2.765	1.526	41.35	11772	4.190	8.737	-3.395	3.942	0.258
600HS300-43	0.0451	0.613	2.09	3.621	1.207	2.430	0.835	1.167	3.493	1.138	20.09	3014	0.416	7.165	-2.584	3.734	0.521
600HS300-54	0.0566	0.767	2.61	4.505	1.502	2.424	1.034	1.161	4.366	1.426	38.32	5682	0.819	8.822	-2.571	3.719	0.522
600HS300-68	0.0713	0.961	3.27	5.613	1.871	2.417	1.281	1.155	5.613	1.871	51.44	7078	1.628	10.842	-2.553	3.701	0.524
600HS300-97	0.1017	1.355	4.61	7.825	2.608	2.403	1.764	1.141	7.825	2.608	77.30	9865	4.672	14.689	-2.517	3.662	0.528
600HS350-54	0.0566	0.823	2.80	5.005	1.668	2.466	1.485	1.343	4.722	1.515	40.20	6743	0.879	12.575	-3.035	4.135	0.461
600HS350-68	0.0713	1.032	3.51	6.240	2.080	2.459	1.843	1.336	6.176	2.044	53.20	8415	1.749	15.485	-3.017	4.115	0.462
600HS350-97	0.1017	1.457	4.95	8.709	2.903	2.445	2.547	1.322	8.710	2.903	78.13	11772	5.023	21.062	-2.981	4.076	0.465
800HS300-43	0.0451	0.704	2.39	7.031	1.758	3.161	0.920	1.144	6.825	1.675	28.41	3014	0.477	12.654	-2.335	4.093	0.674
800HS300-54	0.0566	0.880	2.99	8.759	2.190	3.155	1.140	1.138	8.527	2.097	54.87	5682	0.940	15.604	-2.322	4.080	0.676
800HS300-68	0.0713	1.103	3.75	10.931	2.733	3.148	1.412	1.132	10.931	2.733	75.59	7078	1.870	19.219	-2.305	4.062	0.678
800HS300-97	0.1017	1.559	5.30	15.288	3.822	3.132	1.946	1.117	15.288	3.822	113.11	9865	5.374	26.155	-2.271	4.027	0.682
800HS350-54	0.0566	0.936	3.18	9.662	2.413	3.211	1.640	1.323	9.182	2.225	56.57	6743	1.000	22.249	-2.763	4.437	0.612
800HS350-68	0.0713	1.175	3.99	12.051	3.013	3.203	2.035	1.316	11.922	2.960	77.92	8415	1.990	27.455	-2.746	4.419	0.614
800HS350-97	0.1017	1.660	5.65	16.875	4.219	3.188	2.815	1.302	16.875	4.219	113.83	11772	5.724	37.510	-2.710	4.382	0.618

### Header (H) Section Properties

Section	Design Thickness (in)	Gross Properties							Effective Properties				Torsional				
		Area (in <sup>2</sup> )	Weight (lb/ft)	I <sub>x</sub> (in <sup>4</sup> )	S <sub>x</sub> (in <sup>3</sup> )	R <sub>x</sub> (in)	I <sub>y</sub> (in <sup>4</sup> )	R <sub>y</sub> (in)	I <sub>x</sub> (in <sup>4</sup> )	S <sub>x</sub> (in <sup>3</sup> )	Ma (in-k)	V <sub>ag</sub> (lb)	J <sup>x1000</sup> (in <sup>4</sup> )	C <sub>w</sub> (in <sup>6</sup> )	X <sub>o</sub> (in)	R <sub>o</sub> (in)	β
362JS300-33	0.0346	0.391	1.33	0.894	0.493	1.513	0.540	1.179	0.807	0.479	7.11	2047	1.560	2.383	-2.982	3.544	0.292
362JS300-43	0.0451	0.506	1.72	1.151	0.635	1.507	0.694	1.171	1.106	0.594	10.38	3014	0.343	3.035	-2.969	3.530	0.292
362JS300-54	0.0566	0.632	2.15	1.427	0.787	1.503	0.859	1.165	1.379	0.743	19.75	5682	0.675	3.724	-2.955	3.514	0.293
362JS300-68	0.0713	0.791	2.69	1.771	1.063	1.159	1.063	1.159	1.771	0.977	26.63	7078	1.341	4.556	-2.938	3.495	0.293
362JS300-97	0.1017	1.114	3.79	2.449	1.351	1.483	1.461	1.146	2.444	1.351	40.24	9865	3.840	6.115	-2.902	3.454	0.294
362JS350-54	0.0566	0.689	2.34	1.607	0.887	1.528	1.234	1.339	1.508	0.796	20.84	6743	0.736	5.289	-3.449	4.002	0.258
362JS350-68	0.0713	0.863	2.93	1.996	1.101	1.521	1.531	1.332	1.978	1.084	27.76	8415	1.462	6.484	-3.431	3.983	0.258
362JS350-97	0.1017	1.215	4.13	2.765	1.526	1.508	2.113	1.319	2.765	1.526	41.35	11772	4.190	8.737	-3.395	3.942	0.258
600JS300-33	0.0346	0.473	1.61	2.806	0.935	2.436	0.650	1.172	2.571	0.909	13.05	2047	1.888	5.609	-2.597	3.748	0.520
600JS300-43	0.0451	0.613	2.09	3.621	1.207	2.430	0.835	1.167	3.493	1.138	20.09	3014	0.416	7.165	-2.584	3.734	0.521
600JS300-54	0.0566	0.767	2.61	4.505	1.502	2.424	1.034	1.161	4.366	1.426	38.32	5682	0.819	8.822	-2.571	3.719	0.522
600JS300-68	0.0713	0.961	3.27	5.613	1.871	2.417	1.281	1.155	5.613	1.871	51.44	7078	1.628	10.842	-2.553	3.701	0.524
600JS300-97	0.1017	1.355	4.61	7.825	2.608	2.403	1.764	1.141	7.825	2.608	77.30	9865	4.672	14.689	-2.517	3.662	0.528
600JS350-54	0.0566	0.823	2.80	5.005	1.668	2.466	1.485	1.343	4.722	1.515	40.20	6743	0.879	12.575	-3.035	4.135	0.461
600JS350-68	0.0713	1.032	3.51	6.240	2.080	2.459	1.843	1.336	6.176	2.044	53.20	8415	1.749	15.485	-3.017	4.115	0.462
600JS350-97	0.1017	1.457	4.95	8.709	2.903	2.445	2.547	1.322	8.710	2.903	78.13	11772	5.023	21.062	-2.981	4.076	0.465
800JS300-43	0.0451	0.704	2.39	7.031	1.758	3.161	0.920	1.144	6.825	1.675	28.41	3014	0.477	12.654	-2.335	4.093	0.674
800JS300-54	0.0566	0.880	2.99	8.759	2.190	3.155	1.140	1.138	8.527	2.097	54.87	5682	0.940	15.604	-2.322	4.080	0.676
800JS300-68	0.0713	1.103	3.75	10.931	2.733	3.148	1.412	1.132	10.931	2.733	75.59	7078	1.870	19.219	-2.305	4.062	0.678
800JS300-97	0.1017	1.559	5.30	15.288	3.822	3.132	1.946	1.117	15.288	3.822	113.11	9865	5.374	26.155	-2.271	4.027	0.682
800JS350-54	0.0566	0.936	3.18	9.662	2.413	3.211	1.640	1.323	9.182	2.225	56.57	6743	1.000	22.249	-2.763	4.437	0.612
800JS350-68	0.0713	1.175	3.99	12.051	3.013	3.203	2.035	1.316	11.922	2.960	77.92	8415	1.990	27.455	-2.746	4.419	0.614
800JS350-97	0.1017	1.660	5.65	16.875	4.219	3.188	2.815	1.302	16.875	4.219	113.83	11772	5.724	37.510	-2.710	4.382	0.618

## Clip Properties

### Clip Properties Table Notes

1. Screw strengths based on 8 #10-16 self-drilling tapping screws per ICC Evaluation Report ESR1976.
2. Tabulated values assume 8 screws used in jamb to header connection.
3. Up to 1/4 inch gap between end of header and jamb permitted using 1/4" Gap values.
4. To determine the capacity of a connection, compare the appropriate header and jamb value and use the lower value.
5. Allowable loads have not been increased for wind or seismic.
6. For Lateral and Vertical Forces occurring at the same time, use the interaction equation  $(f1/F1)^2 + (f2/F2)^2 < 1.07$ .
7. Table to be used by qualified engineers only.

### Clip Profile Dimensions

Clip Section	Design Thickness (in)	Gauge	Leg Length (in)	Clip Length (in)	Web Width (in)	Yield (ksi)	Coat
306HC350-68	0.0713	14	2.0625	3.500	3.0625	50	G90
356HC350-68	0.0713	14	2.0625	3.500	3.5625	50	G90
306HC588-68	0.0713	14	2.0625	5.875	3.0625	50	G90
356HC588-68	0.0713	14	2.0625	5.875	3.5625	50	G90
306HC788-68	0.0713	14	2.0625	7.875	3.0625	50	G90
356HC788-68	0.0713	14	2.0625	7.875	3.5625	50	G90

### Allowable loads (lbs.)

Jamb Section	Header Section	Clip Section	Clip Strength				
			Lateral Force (lbs)		Vertical Force (lbs)		
			Jamb	Header	Jamb	Header	
						No Gap	1/4" Gap
362JS300-43	362HS300-43	306HC350-68	1052	838	1052	740	611
362JS300-54	362HS300-54	306HC350-68	1972	1570	1972	1008	786
362JS300-68	362HS300-68	306HC350-68	1972	1570	1972	1110	786
362JS300-97	362HS300-97	306HC350-68	1972	1570	1972	1224	786
362JS350-54	362HS350-54	356HC350-68	1972	1570	1972	1008	786
362JS350-68	362HS350-68	356HC350-68	1972	1570	1972	1110	786
362JS350-97	362HS350-97	356HC350-68	1972	1570	1972	1224	786
600JS300-43	600HS300-43	306HC588-68	1052	978	1052	1262	878
600JS300-54	600HS300-54	306HC588-68	1972	1832	1972	1440	1056
600JS300-68	600HS300-68	306HC588-68	1972	1832	1972	1542	1158
600JS300-97	600HS300-97	306HC588-68	1972	1832	1972	1756	1319
600JS350-54	600HS350-54	356HC588-68	1972	1832	1972	1440	1056
600JS350-68	600HS350-68	356HC588-68	1972	1832	1972	1542	1158
600JS350-97	600HS350-97	356HC588-68	1972	1832	1972	1756	1319
800JS300-43	800HS300-43	306HC788-68	1052	996	1052	1262	878
800JS300-54	800HS300-54	306HC788-68	1972	1867	1972	1440	1056
800JS300-68	800HS300-68	306HC788-68	1972	1867	1972	1542	1158
800JS300-97	800HS300-97	306HC788-68	1972	1867	1972	1756	1319
800JS350-54	800HS350-54	356HC788-68	1972	1867	1972	1440	1056
800JS350-68	800HS350-68	356HC788-68	1972	1867	1972	1542	1158
800JS350-97	800HS350-97	356HC788-68	1972	1867	1972	1756	1319

## Interior Span Chart (3.0" Flange)

### Interior Structural Composite Table Notes

1. Deflections are computed using 1.0 times the listed wind load.
2. Header to be installed with open side facing up and a track fastened over the open end.
3. Table calculations are in accordance with the AISI S100-16/S2-20.
4. Headers are assumed to be connected using the corresponding standard clip and fastener pattern.
5. For deflection calculations, the effective moment of inertia, calculated at the maximum service load, was used.
6. The calculated flexural strength of the header was based upon  $L_b \leq L_u$ .
7. Header framing was calculated assuming a worse case condition of a sill height at ground.
8. This table is not applicable for load bearing walls but is applicable for a curtain wall application.
9. Tables were prepared using a 16" o.c. spacing from the jamb stud to the first adjacent typical wall stud.
10. Tabled widths marked with an \* (asterisk) require special engineering of the clip connection.
11. The strength analysis included separate bending and shear checks.
12. Unless connections are engineered separately, jambs must be the same or greater gauge and yield strength as the header.
13. Opening width is also limited by jamb considerations. See jamb table for limits.
14. Headers are assumed to be connected to the jamb with matching 14 gage 50 ksi MBA clips using 8 #10-16 screws.
15. Table to be used by qualified engineers only.

**Allowable header spans (Dead Load = 10psf , Wind Load = 5psf )**

Wall Height (ft)	Section	F <sub>y</sub> (ksi)	L/240			L/360			L/600		
			Opening Height (ft)			Opening Height (ft)			Opening Height (ft)		
			7ft	8ft	9ft	7ft	8ft	9ft	7ft	8ft	9ft
9	362HS300-43	33	11'-7"	13'-8"		11'-7"	13'-8"		11'-7"	13'-8"	
	362HS300-54	50	12'-10"	15'-4"		12'-10"	15'-4"		12'-10"	15'-4"	
	362HS300-68	50	13'-7"	16'-2"		13'-7"	16'-2"		13'-7"	16'-2"	
	362HS300-97	50	14'-9"	17'-7"		14'-9"	17'-7"		14'-9"	17'-7"	
	600HS300-43	33	12'-9"	15'-2"		12'-9"	15'-2"		12'-9"	15'-2"	
	600HS300-54	50	13'-6"	16'-0"		13'-6"	16'-0"		13'-6"	16'-0"	
	600HS300-68	50	14'-3"	17'-0"		14'-3"	17'-0"		14'-3"	17'-0"	
	600HS300-97	50	15'-5"	18'-5"		15'-5"	18'-5"		15'-5"	18'-5"	
	800HS300-43	33	13'-1"	15'-7"		13'-1"	15'-7"		13'-1"	15'-7"	
	800HS300-54	50	13'-10"	16'-5"		13'-10"	16'-5"		13'-10"	16'-5"	
	800HS300-68	50	14'-7"	17'-5"		14'-7"	17'-5"		14'-7"	17'-5"	
	800HS300-97	50	15'-10"	18'-10"		15'-10"	18'-10"		15'-10"	18'-10"	
11	362HS300-43	33	9'-0"	9'-10"	11'-0"	9'-0"	9'-10"	11'-0"	9'-0"	9'-10"	11'-0"
	362HS300-54	50	10'-10"	11'-8"	12'-10"	10'-10"	11'-8"	12'-10"	10'-10"	11'-11"	10'-11"
	362HS300-68	50	11'-5"	12'-4"	13'-7"	11'-5"	12'-4"	13'-7"	11'-5"	11'-10"	11'-10"
	362HS300-97	50	12'-5"	13'-4"	14'-9"	12'-5"	13'-4"	14'-9"	12'-5"	13'-3"	13'-3"
	600HS300-43	33	10'-0"	11'-2"	12'-9"	10'-0"	11'-2"	12'-9"	10'-0"	11'-2"	12'-9"
	600HS300-54	50	11'-4"	12'-2"	13'-6"	11'-4"	12'-2"	13'-6"	11'-4"	12'-2"	13'-6"
	600HS300-68	50	12'-0"	12'-11"	14'-3"	12'-0"	12'-11"	14'-3"	12'-0"	12'-11"	14'-3"
	600HS300-97	50	13'-0"	14'-0"	15'-5"	13'-0"	14'-0"	15'-5"	13'-0"	14'-0"	15'-5"
	800HS300-43	33	10'-6"	11'-9"	13'-1"	10'-6"	11'-9"	13'-1"	10'-6"	11'-9"	13'-1"
	800HS300-54	50	11'-7"	12'-6"	13'-10"	11'-7"	12'-6"	13'-10"	11'-7"	12'-6"	13'-10"
	800HS300-68	50	12'-3"	13'-2"	14'-7"	12'-3"	13'-2"	14'-7"	12'-3"	13'-2"	14'-7"
	800HS300-97	50	13'-4"	14'-4"	15'-10"	13'-4"	14'-4"	15'-10"	13'-4"	14'-4"	15'-10"
13	362HS300-43	33	7'-7"	8'-1"	8'-8"	7'-7"	8'-1"	8'-8"	7'-7"	8'-1"	8'-8"
	362HS300-54	50	9'-9"	10'-3"	10'-10"	9'-9"	10'-3"	10'-10"	9'-9"	10'-3"	10'-4"
	362HS300-68	50	10'-4"	10'-10"	11'-5"	10'-4"	10'-10"	11'-5"	10'-4"	10'-10"	11'-3"
	362HS300-97	50	11'-2"	11'-9"	12'-5"	11'-2"	11'-9"	12'-5"	11'-2"	11'-9"	12'-5"
	600HS300-43	33	8'-4"	9'-0"	9'-10"	8'-4"	9'-0"	9'-10"	8'-4"	9'-0"	9'-10"
	600HS300-54	50	10'-3"	10'-9"	11'-4"	10'-3"	10'-9"	11'-4"	10'-3"	11'-4"	11'-4"
	600HS300-68	50	10'-10"	11'-4"	12'-0"	10'-10"	11'-4"	12'-0"	10'-10"	11'-4"	12'-0"
	600HS300-97	50	11'-9"	12'-3"	13'-0"	11'-9"	12'-3"	13'-0"	11'-9"	12'-3"	13'-0"
	800HS300-43	33	8'-8"	9'-5"	10'-4"	8'-8"	9'-5"	10'-4"	8'-8"	9'-5"	10'-4"
	800HS300-54	50	10'-6"	11'-0"	11'-7"	10'-6"	11'-0"	11'-7"	10'-6"	11'-0"	11'-7"
	800HS300-68	50	11'-1"	11'-7"	12'-3"	11'-1"	11'-7"	12'-3"	11'-1"	11'-7"	12'-3"
	800HS300-97	50	12'-0"	12'-7"	13'-4"	12'-0"	12'-7"	13'-4"	12'-0"	12'-7"	13'-4"
15	362HS300-43	33	6'-8"	7'-0"	7'-5"	6'-8"	7'-0"	7'-5"	6'-8"	7'-0"	7'-5"
	362HS300-54	50	8'-10"	9'-3"	9'-9"	8'-10"	9'-3"	9'-9"	8'-10"	9'-3"	9'-9"
	362HS300-68	50	9'-6"	9'-11"	10'-4"	9'-6"	9'-11"	10'-4"	9'-6"	9'-11"	10'-4"
	362HS300-97	50	10'-5"	10'-9"	11'-2"	10'-5"	10'-9"	11'-2"	10'-5"	10'-9"	11'-2"
	600HS300-43	33	7'-4"	7'-9"	8'-3"	7'-4"	7'-9"	8'-3"	7'-4"	7'-9"	8'-3"
	600HS300-54	50	9'-5"	9'-10"	10'-3"	9'-5"	9'-10"	10'-3"	9'-5"	9'-10"	10'-3"
	600HS300-68	50	10'-1"	10'-5"	10'-10"	10'-1"	10'-5"	10'-10"	10'-1"	10'-5"	10'-10"
	600HS300-97	50	10'-11"	11'-3"	11'-9"	10'-11"	11'-3"	11'-9"	10'-11"	11'-3"	11'-9"
	800HS300-43	33	7'-7"	8'-1"	8'-7"	7'-7"	8'-1"	8'-7"	7'-7"	8'-1"	8'-7"
	800HS300-54	50	9'-8"	10'-1"	10'-6"	9'-8"	10'-1"	10'-6"	9'-8"	10'-1"	10'-6"
	800HS300-68	50	10'-4"	10'-8"	11'-1"	10'-4"	10'-8"	11'-1"	10'-4"	10'-8"	11'-1"
	800HS300-97	50	11'-2"	11'-7"	12'-0"	11'-2"	11'-7"	12'-0"	11'-2"	11'-7"	12'-0"

## Interior Span Chart (3.5" Flange)

### Interior Structural Composite Table Notes

1. Deflections are computed using 1.0 times the listed wind load.
2. Header to be installed with open side facing up and a track fastened over the open end.
3. Table calculations are in accordance with the AISI S100-16/S2-20.
4. Headers are assumed to be connected using the corresponding standard clip and fastener pattern.
5. For deflection calculations, the effective moment of inertia, calculated at the maximum service load, was used.
6. The calculated flexural strength of the header was based upon  $L_b \leq L_u$ .
7. Header framing was calculated assuming a worse case condition of a sill height at ground.
8. This table is not applicable for load bearing walls but is applicable for a curtain wall application.
9. Tables were prepared using a 16" o.c. spacing from the jamb stud to the first adjacent typical wall stud.
10. Tabled widths marked with an \* (asterisk) require special engineering of the clip connection.
11. The strength analysis included separate bending and shear checks.
12. Unless connections are engineered separately, jambs must be the same or greater gauge and yield strength as the header.
13. Opening width is also limited by jamb considerations. See jamb table for limits.
14. Headers are assumed to be connected to the jamb with matching 14 gage 50 ksi MBA clips using 8 #10-16 screws.
15. Table to be used by qualified engineers only.

### Allowable header spans (Dead Load = 10psf , Wind Load = 5psf )

Wall Height (ft)	Section	F <sub>y</sub> (ksi)	L/240			L/360			L/600		
			Opening Height (ft)			Opening Height (ft)			Opening Height (ft)		
			7ft	8ft	9ft	7ft	8ft	9ft	7ft	8ft	9ft
9	362HS350-54	50	14'-1"	16'-4"		14'-1"	16'-4"		14'-1"	16'-4"	
	362HS350-68	50	14'-11"	17'-9"		14'-11"	17'-9"		14'-11"	17'-9"	
	362HS350-97	50	16'-2"	19'-3"		16'-2"	19'-3"		16'-2"	19'-3"	
	600HS350-54	50	14'-9"	17'-7"		14'-9"	17'-7"		14'-9"	17'-7"	
	600HS350-68	50	15'-8"	18'-7"		15'-8"	18'-7"		15'-8"	18'-7"	
	600HS350-97	50	17'-0"	20'-2"		17'-0"	20'-2"		17'-0"	20'-2"	
	800HS350-54	50	15'-2"	18'-0"		15'-2"	18'-0"		15'-2"	18'-0"	
	800HS350-68	50	16'-0"	19'-1"		16'-0"	19'-1"		16'-0"	19'-1"	
11	362HS350-54	50	11'-10"	12'-9"	14'-1"	11'-10"	12'-9"	13'-4"	11'-3"	11'-3"	11'-3"
	362HS350-68	50	12'-7"	13'-6"	14'-11"	12'-7"	13'-6"	14'-7"	12'-4"	12'-4"	12'-4"
	362HS350-97	50	13'-7"	14'-7"	16'-2"	13'-7"	14'-7"	16'-2"	13'-9"	13'-9"	13'-9"
	600HS350-54	50	12'-5"	13'-4"	14'-9"	12'-5"	13'-4"	14'-9"	12'-5"	13'-4"	14'-9"
	600HS350-68	50	13'-2"	14'-1"	15'-8"	13'-2"	14'-1"	15'-8"	13'-2"	14'-1"	15'-8"
	600HS350-97	50	14'-3"	15'-4"	17'-0"	14'-3"	15'-4"	17'-0"	14'-3"	15'-4"	17'-0"
	800HS350-54	50	12'-9"	13'-8"	15'-2"	12'-9"	13'-8"	15'-2"	12'-9"	13'-8"	15'-2"
	800HS350-68	50	13'-6"	14'-6"	16'-0"	13'-6"	14'-6"	16'-0"	13'-6"	14'-6"	16'-0"
13	362HS350-54	50	11'-10"	12'-9"	14'-1"	11'-10"	12'-9"	13'-4"	11'-3"	11'-3"	11'-3"
	362HS350-68	50	12'-7"	13'-6"	14'-11"	12'-7"	13'-6"	14'-7"	12'-4"	12'-4"	12'-4"
	362HS350-97	50	13'-7"	14'-7"	16'-2"	13'-7"	14'-7"	16'-2"	13'-9"	13'-9"	13'-9"
	600HS350-54	50	12'-5"	13'-4"	14'-9"	12'-5"	13'-4"	14'-9"	12'-5"	13'-4"	14'-9"
	600HS350-68	50	13'-2"	14'-1"	15'-8"	13'-2"	14'-1"	15'-8"	13'-2"	14'-1"	15'-8"
	600HS350-97	50	14'-3"	15'-4"	17'-0"	14'-3"	15'-4"	17'-0"	14'-3"	15'-4"	17'-0"
	800HS350-54	50	12'-9"	13'-8"	15'-2"	12'-9"	13'-8"	15'-2"	12'-9"	13'-8"	15'-2"
	800HS350-68	50	13'-6"	14'-6"	16'-0"	13'-6"	14'-6"	16'-0"	13'-6"	14'-6"	16'-0"
15	362HS350-54	50	9'-11"	10'-4"	10'-8"	9'-11"	10'-4"	10'-8"	10'-2"	10'-2"	10'-2"
	362HS350-68	50	10'-6"	10'-11"	11'-4"	10'-6"	10'-11"	11'-4"	10'-6"	10'-11"	11'-1"
	362HS350-97	50	11'-5"	11'-10"	12'-3"	11'-5"	11'-10"	12'-3"	11'-5"	11'-10"	12'-3"
	600HS350-54	50	10'-5"	10'-9"	11'-3"	10'-5"	10'-9"	11'-3"	10'-5"	10'-9"	11'-3"
	600HS350-68	50	11'-0"	11'-5"	11'-10"	11'-0"	11'-5"	11'-10"	11'-0"	11'-5"	11'-10"
	600HS350-97	50	12'-0"	12'-5"	12'-11"	12'-0"	12'-5"	12'-11"	12'-0"	12'-5"	12'-11"
	800HS350-54	50	10'-8"	11'-1"	11'-6"	10'-8"	11'-1"	11'-6"	10'-8"	11'-1"	11'-6"
	800HS350-68	50	11'-4"	11'-9"	12'-2"	11'-4"	11'-9"	12'-2"	11'-4"	11'-9"	12'-2"
800HS350-97	50	12'-3"	12'-8"	13'-2"	12'-3"	12'-8"	13'-2"	12'-3"	12'-8"	13'-2"	

## Exterior Span Chart (3.0" Flange)

### Exterior Structural Composite Table Notes

1. Deflections are computed using 0.7 times the listed wind load.
2. Header to be installed with open side facing up and a track fastened over the open end.
3. Table calculations are in accordance with the AISI S100-16/S2-20.
4. Headers are assumed to be connected using the corresponding standard clip and fastener pattern.
5. For deflection calculations, the effective moment of inertia, calculated at the maximum service load, was used.
6. The calculated flexural strength of the header was based upon  $L_b \leq L_u$ .
7. Header framing was calculated assuming a worse case condition of a sill height at ground.
8. This table is not applicable for load bearing walls but is applicable for a curtain wall application.
9. Tables were prepared using a 16" o.c. spacing from the jamb stud to the first adjacent typical wall stud.
10. Tabled widths marked with an \* (asterisk) require special engineering of the clip connection.
11. The strength analysis included separate bending and shear checks.
12. Unless connections are engineered separately, jambs must be the same or greater gauge and yield strength as the header.
13. Opening width is also limited by jamb considerations. See jamb table for limits.
14. Headers are assumed to be connected to the jamb with matching 14 gage 50 ksi MBA clips using 8 #10-16 screws.
15. Table to be used by qualified engineers only.

### Allowable header spans (Dead Load = 12psf , Wind Load = 20psf )

Wall Height (ft)	Section	Fy (ksi)	L/240			L/360			L/600		
			Opening Height (ft)			Opening Height (ft)			Opening Height (ft)		
			8ft	10ft	12ft	8ft	10ft	12ft	8ft	10ft	12ft
9	362HS300-43	33	8'-0"			8'-0"			8'-0"		
	362HS300-54	50	11'-0"			11'-0"			11'-0"		
	362HS300-68	50	12'-3"			12'-3"			12'-3"		
	362HS300-97	50	13'-7"			13'-7"			13'-7"		
	600HS300-43	33	10'-5"			10'-5"			10'-5"		
	600HS300-54	50	14'-5"			14'-5"			12'-2"		
	600HS300-68	50	16'-3"			15'-8"			13'-3"		
	600HS300-97	50	17'-7"			17'-6"			14'-9"		
	800HS300-43	33	11'-11"			11'-11"			11'-11"		
	800HS300-54	50	15'-9"			15'-9"			15'-3"		
800HS300-68	50	16'-7"			16'-7"			16'-6"			
800HS300-97	50	18'-0"			18'-0"			18'-0"			
11	362HS300-43	33	6'-6"	7'-4"		6'-6"	7'-4"		6'-6"	7'-2"	
	362HS300-54	50	9'-0"	10'-1"		9'-0"	9'-2"		7'-9"	7'-9"	
	362HS300-68	50	10'-5"	11'-5"		10'-0"	10'-0"		8'-5"	8'-5"	
	362HS300-97	50	12'-8"	12'-9"		11'-1"	11'-1"		9'-4"	9'-4"	
	600HS300-43	33	8'-1"	9'-8"		8'-1"	9'-8"		8'-1"	9'-8"	
	600HS300-54	50	11'-1"	13'-5"		11'-1"	13'-5"		11'-1"	11'-4"	
	600HS300-68	50	12'-4"	15'-6"		12'-4"	14'-8"		12'-4"	12'-4"	
	600HS300-97	50	13'-4"	17'-7"		13'-4"	16'-5"		13'-4"	13'-10"	
	800HS300-43	33	8'-10"	11'-1"		8'-10"	11'-1"		8'-10"	11'-1"	
	800HS300-54	50	11'-11"	15'-4"		11'-11"	15'-4"		11'-11"	14'-3"	
800HS300-68	50	12'-7"	16'-7"		12'-7"	16'-7"		12'-7"	15'-5"		
800HS300-97	50	13'-8"	18'-0"		13'-8"	18'-0"		13'-8"	17'-3"		
13	362HS300-43	33	5'-7"	6'-1"	6'-10"	5'-7"	6'-1"	6'-10"	5'-7"	6'-1"	6'-10"
	362HS300-54	50	7'-9"	8'-5"	9'-5"	7'-9"	8'-5"	9'-5"	7'-4"	7'-4"	7'-4"
	362HS300-68	50	9'-0"	9'-10"	10'-10"	9'-0"	9'-5"	9'-5"	7'-11"	7'-11"	7'-11"
	362HS300-97	50	10'-11"	11'-11"	12'-1"	10'-6"	10'-6"	10'-6"	8'-10"	8'-10"	8'-10"
	600HS300-43	33	6'-9"	7'-8"	9'-1"	6'-9"	7'-8"	9'-1"	6'-9"	7'-8"	9'-1"
	600HS300-54	50	9'-4"	10'-7"	12'-6"	9'-4"	10'-7"	12'-6"	9'-4"	10'-7"	10'-9"
	600HS300-68	50	10'-10"	12'-3"	14'-6"	10'-10"	12'-3"	13'-10"	10'-10"	11'-8"	11'-8"
	600HS300-97	50	11'-9"	13'-4"	17'-7"	11'-9"	13'-4"	15'-6"	11'-9"	13'-1"	13'-1"
	800HS300-43	33	7'-4"	8'-6"	10'-5"	7'-4"	8'-6"	10'-5"	7'-4"	8'-6"	10'-5"
	800HS300-54	50	10'-2"	11'-9"	14'-6"	10'-2"	11'-9"	14'-6"	10'-2"	11'-9"	13'-5"
800HS300-68	50	11'-1"	12'-7"	16'-7"	11'-1"	12'-7"	16'-7"	11'-1"	12'-7"	14'-7"	
800HS300-97	50	12'-0"	13'-8"	18'-0"	12'-0"	13'-8"	18'-0"	12'-0"	13'-8"	16'-4"	
15	362HS300-43	33	5'-0"	5'-4"	5'-10"	5'-0"	5'-4"	5'-10"	5'-0"	5'-4"	5'-10"
	362HS300-54	50	6'-11"	7'-5"	8'-0"	6'-11"	7'-5"	8'-0"	6'-11"	7'-0"	7'-0"
	362HS300-68	50	8'-0"	8'-7"	9'-4"	8'-0"	8'-7"	9'-0"	7'-7"	7'-7"	7'-7"
	362HS300-97	50	9'-8"	10'-5"	11'-4"	9'-8"	10'-0"	10'-0"	8'-5"	8'-5"	8'-5"
	600HS300-43	33	6'-0"	6'-7"	7'-4"	6'-0"	6'-7"	7'-4"	6'-0"	6'-7"	7'-4"
	600HS300-54	50	8'-3"	9'-1"	10'-2"	8'-3"	9'-1"	10'-2"	8'-3"	9'-1"	10'-2"
	600HS300-68	50	9'-6"	10'-6"	11'-9"	9'-6"	10'-6"	11'-9"	9'-6"	10'-6"	11'-2"
	600HS300-97	50	10'-9"	11'-9"	13'-4"	10'-9"	11'-9"	13'-4"	10'-9"	11'-9"	12'-5"
	800HS300-43	33	6'-5"	7'-2"	8'-2"	6'-5"	7'-2"	8'-2"	6'-5"	7'-2"	8'-2"
	800HS300-54	50	8'-11"	9'-11"	11'-4"	8'-11"	9'-11"	11'-4"	8'-11"	9'-11"	11'-4"
800HS300-68	50	10'-2"	11'-1"	12'-7"	10'-2"	11'-1"	12'-7"	10'-2"	11'-1"	12'-7"	
800HS300-97	50	11'-1"	12'-0"	13'-8"	11'-1"	12'-0"	13'-8"	11'-1"	12'-0"	13'-8"	

## Exterior Span Chart (3.5" Flange)

### Exterior Structural Composite Table Notes

1. Deflections are computed using 0.7 times the listed wind load.
2. Header to be installed with open side facing up and a track fastened over the open end.
3. Table calculations are in accordance with the AISI S100-16/S2-20.
4. Headers are assumed to be connected using the corresponding standard clip and fastener pattern.
5. For deflection calculations, the effective moment of inertia, calculated at the maximum service load, was used.
6. The calculated flexural strength of the header was based upon  $L_b \leq L_u$ .
7. Header framing was calculated assuming a worse case condition of a sill height at ground.
8. This table is not applicable for load bearing walls but is applicable for a curtain wall application.
9. Tables were prepared using a 16" o.c. spacing from the jamb stud to the first adjacent typical wall stud.
10. Tabled widths marked with an \* (asterisk) require special engineering of the clip connection.
11. The strength analysis included separate bending and shear checks.
12. Unless connections are engineered separately, jambs must be the same or greater gauge and yield strength as the header.
13. Opening width is also limited by jamb considerations. See jamb table for limits.
14. Headers are assumed to be connected to the jamb with matching 14 gage 50 ksi MBA clips using 8 #10-16 screws.
15. Table to be used by qualified engineers only.

**Allowable header spans (Dead Load = 12psf , Wind Load = 20psf )**

Wall Height (ft)	Section	Fy (ksi)	L/240			L/360			L/600		
			Opening Height (ft)			Opening Height (ft)			Opening Height (ft)		
			8ft	10ft	12ft	8ft	10ft	12ft	8ft	10ft	12ft
9	362HS350-54	50	11'-6"			11'-6"			11'-6"		
	362HS350-68	50	12'-8"			12'-8"			12'-8"		
	362HS350-97	50	14'-2"			14'-2"			14'-2"		
	600HS350-54	50	15'-2"			14'-10"			12'-6"		
	600HS350-68	50	17'-5"			16'-2"			13'-8"		
	600HS350-97	50	19'-3"			18'-2"			15'-4"		
	800HS350-54	50	17'-2"			17'-2"			15'-7"		
	800HS350-68	50	18'-3"			18'-3"			17'-0"		
11	800HS350-97	50	19'-9"			19'-9"			19'-1"		
	362HS350-54	50	9'-5"	10'-6"		9'-5"	9'-5"		8'-0"	8'-0"	
	362HS350-68	50	10'-11"	11'-10"		10'-4"	10'-4"		8'-9"	8'-9"	
	362HS350-97	50	13'-3"	13'-3"		11'-7"	11'-7"		9'-9"	9'-9"	
	600HS350-54	50	11'-10"	14'-0"		11'-10"	13'-10"		11'-8"	11'-8"	
	600HS350-68	50	13'-6"	16'-1"		13'-6"	15'-2"		12'-9"	12'-9"	
	600HS350-97	50	14'-8"	19'-3"		14'-8"	17'-0"		14'-4"	14'-4"	
	800HS350-54	50	13'-1"	16'-0"		13'-1"	16'-0"		13'-1"	14'-7"	
13	800HS350-68	50	13'-10"	18'-3"		13'-10"	18'-3"		13'-10"	15'-11"	
	800HS350-97	50	15'-0"	19'-9"		15'-0"	19'-9"		15'-0"	17'-10"	
	362HS350-54	50	8'-3"	8'-11"	9'-9"	8'-3"	8'-11"	8'-11"	7'-6"	7'-6"	7'-6"
	362HS350-68	50	9'-6"	10'-3"	11'-3"	9'-6"	9'-10"	9'-10"	8'-3"	8'-3"	8'-3"
	362HS350-97	50	11'-6"	12'-5"	12'-7"	10'-11"	10'-11"	10'-11"	9'-3"	9'-3"	9'-3"
	600HS350-54	50	10'-1"	11'-3"	13'-1"	10'-1"	11'-3"	10'-1"	11'-0"	11'-0"	11'-0"
	600HS350-68	50	11'-7"	13'-0"	15'-0"	11'-7"	13'-0"	14'-4"	11'-7"	12'-1"	12'-1"
	600HS350-97	50	12'-11"	14'-8"	18'-2"	12'-11"	14'-8"	16'-1"	12'-11"	13'-7"	13'-7"
15	800HS350-54	50	11'-0"	12'-7"	15'-0"	11'-0"	12'-7"	15'-0"	11'-0"	12'-7"	13'-9"
	800HS350-68	50	12'-2"	13'-10"	17'-7"	12'-2"	13'-10"	17'-7"	12'-2"	13'-10"	15'-1"
	800HS350-97	50	13'-2"	15'-0"	19'-9"	13'-2"	15'-0"	19'-9"	13'-2"	15'-0"	16'-11"
	362HS350-54	50	7'-4"	7'-10"	8'-5"	7'-4"	7'-10"	8'-5"	7'-2"	7'-2"	7'-2"
	362HS350-68	50	8'-6"	9'-1"	9'-9"	8'-6"	9'-1"	9'-4"	7'-10"	7'-10"	7'-10"
	362HS350-97	50	10'-3"	11'-0"	11'-10"	10'-3"	10'-5"	10'-5"	8'-10"	8'-10"	8'-10"
	600HS350-54	50	8'-11"	9'-8"	10'-9"	9'-8"	9'-8"	10'-9"	8'-11"	9'-8"	10'-6"
	600HS350-68	50	10'-3"	11'-2"	12'-5"	10'-3"	11'-2"	12'-5"	10'-3"	11'-2"	11'-6"
600HS350-97	50	11'-10"	12'-11"	14'-8"	11'-10"	12'-11"	14'-8"	11'-10"	12'-11"	12'-11"	
800HS350-54	50	9'-8"	10'-8"	12'-1"	9'-8"	10'-8"	12'-1"	9'-8"	10'-8"	12'-1"	
800HS350-68	50	11'-2"	12'-2"	13'-10"	11'-2"	12'-2"	13'-10"	11'-2"	12'-2"	13'-10"	
800HS350-97	50	12'-2"	13'-2"	15'-0"	12'-2"	13'-2"	15'-0"	12'-2"	13'-2"	15'-0"	

## Exterior Span Chart (3.0" Flange)

### Exterior Structural Composite Table Notes

1. Deflections are computed using 0.7 times the listed wind load.
2. Header to be installed with open side facing up and a track fastened over the open end.
3. Table calculations are in accordance with the AISI S100-16/S2-20.
4. Headers are assumed to be connected using the corresponding standard clip and fastener pattern.
5. For deflection calculations, the effective moment of inertia, calculated at the maximum service load, was used.
6. The calculated flexural strength of the header was based upon  $L_b \leq L_u$ .
7. Header framing was calculated assuming a worse case condition of a sill height at ground.
8. This table is not applicable for load bearing walls but is applicable for a curtain wall application.
9. Tables were prepared using a 16" o.c. spacing from the jamb stud to the first adjacent typical wall stud.
10. Tabled widths marked with an \* (asterisk) require special engineering of the clip connection.
11. The strength analysis included separate bending and shear checks.
12. Unless connections are engineered separately, jambs must be the same or greater gauge and yield strength as the header.
13. Opening width is also limited by jamb considerations. See jamb table for limits.
14. Headers are assumed to be connected to the jamb with matching 14 gage 50 ksi MBA clips using 8 #10-16 screws.
15. Table to be used by qualified engineers only.

### Allowable header spans (Dead Load = 12psf , Wind Load = 25psf )

Wall Height (ft)	Section	Fy (ksi)	L/240			L/360			L/600		
			Opening Height (ft)			Opening Height (ft)			Opening Height (ft)		
			8ft	10ft	12ft	8ft	10ft	12ft	8ft	10ft	12ft
9	362HS300-43	33	7'-3"			7'-3"			7'-3"		
	362HS300-54	50	10'-0"			10'-0"			10'-0"		
	362HS300-68	50	11'-4"			11'-4"			11'-4"		
	362HS300-97	50	12'-8"			12'-8"			12'-8"		
	600HS300-43	33	9'-7"			9'-7"			9'-7"		
	600HS300-54	50	13'-3"			13'-3"			11'-3"		
	600HS300-68	50	15'-4"			14'-7"			12'-3"		
	600HS300-97	50	17'-7"			16'-3"			13'-9"		
	800HS300-43	33	11'-0"			11'-0"			11'-0"		
	800HS300-54	50	15'-3"			15'-3"			14'-1"		
800HS300-68	50	16'-7"			16'-7"			15'-4"			
800HS300-97	50	18'-0"			18'-0"			17'-2"			
11	362HS300-43	33	6'-0"	6'-8"		6'-0"	6'-8"		6'-0"	6'-8"	
	362HS300-54	50	8'-3"	9'-2"		8'-3"	8'-6"		7'-2"	7'-2"	
	362HS300-68	50	9'-7"	10'-7"		9'-3"	9'-3"		7'-10"	7'-10"	
	362HS300-97	50	11'-9"	11'-10"		10'-4"	10'-4"		8'-8"	8'-8"	
	600HS300-43	33	7'-7"	8'-10"		7'-7"	8'-10"		7'-7"	8'-10"	
	600HS300-54	50	10'-5"	12'-3"		10'-5"	12'-3"		10'-5"	10'-7"	
	600HS300-68	50	12'-1"	14'-2"		12'-1"	13'-7"		11'-6"	11'-6"	
	600HS300-97	50	13'-4"	17'-4"		13'-4"	15'-3"		12'-10"	12'-10"	
	800HS300-43	33	8'-5"	10'-2"		8'-5"	10'-2"		8'-5"	10'-2"	
	800HS300-54	50	11'-7"	14'-2"		11'-7"	14'-2"		11'-7"	13'-2"	
800HS300-68	50	12'-7"	16'-7"		12'-7"	16'-7"		12'-7"	14'-4"		
800HS300-97	50	13'-8"	18'-0"		13'-8"	18'-0"		13'-8"	16'-1"		
13	362HS300-43	33	5'-3"	5'-8"	6'-2"	5'-3"	5'-8"	6'-2"	5'-3"	5'-8"	6'-2"
	362HS300-54	50	7'-3"	7'-9"	8'-6"	7'-3"	7'-9"	8'-1"	6'-9"	6'-9"	6'-9"
	362HS300-68	50	8'-4"	9'-0"	9'-11"	8'-4"	8'-9"	8'-9"	7'-5"	7'-5"	7'-5"
	362HS300-97	50	10'-2"	11'-0"	11'-2"	9'-9"	9'-9"	9'-9"	8'-3"	8'-3"	8'-3"
	600HS300-43	33	6'-5"	7'-2"	8'-3"	6'-5"	7'-2"	8'-3"	6'-5"	7'-2"	8'-3"
	600HS300-54	50	8'-11"	9'-11"	11'-5"	8'-11"	9'-11"	11'-5"	8'-11"	9'-11"	10'-0"
	600HS300-68	50	10'-3"	11'-6"	13'-3"	10'-3"	11'-6"	12'-11"	10'-3"	10'-10"	10'-10"
	600HS300-97	50	11'-9"	13'-4"	16'-2"	11'-9"	13'-4"	14'-5"	11'-9"	12'-2"	12'-2"
	800HS300-43	33	7'-0"	8'-0"	9'-7"	7'-0"	8'-0"	9'-7"	7'-0"	8'-0"	9'-7"
	800HS300-54	50	9'-9"	11'-1"	13'-3"	9'-9"	11'-1"	13'-3"	9'-9"	11'-1"	12'-6"
800HS300-68	50	11'-1"	12'-7"	15'-6"	11'-1"	12'-7"	15'-6"	11'-1"	12'-7"	13'-7"	
800HS300-97	50	12'-0"	13'-8"	18'-0"	12'-0"	13'-8"	18'-0"	12'-0"	13'-8"	15'-2"	
15	362HS300-43	33	4'-8"	5'-0"	5'-4"	4'-8"	5'-0"	5'-4"	4'-8"	5'-0"	5'-4"
	362HS300-54	50	6'-6"	6'-11"	7'-4"	6'-6"	6'-11"	7'-4"	6'-6"	6'-6"	6'-6"
	362HS300-68	50	7'-6"	8'-0"	8'-7"	7'-6"	8'-0"	8'-4"	7'-0"	7'-0"	7'-0"
	362HS300-97	50	9'-1"	9'-9"	10'-5"	9'-1"	9'-4"	9'-4"	7'-10"	7'-10"	7'-10"
	600HS300-43	33	5'-8"	6'-2"	6'-10"	5'-8"	6'-2"	6'-10"	5'-8"	6'-2"	6'-10"
	600HS300-54	50	7'-10"	8'-7"	9'-6"	7'-10"	8'-7"	9'-6"	7'-10"	8'-7"	9'-6"
	600HS300-68	50	9'-1"	9'-11"	10'-11"	9'-1"	9'-11"	10'-11"	9'-1"	9'-11"	10'-4"
	600HS300-97	50	10'-9"	11'-9"	13'-4"	10'-9"	11'-9"	13'-4"	10'-9"	11'-7"	11'-7"
	800HS300-43	33	6'-2"	6'-10"	7'-8"	6'-2"	6'-10"	7'-8"	6'-2"	6'-10"	7'-8"
	800HS300-54	50	8'-7"	9'-5"	10'-8"	8'-7"	9'-5"	10'-8"	8'-7"	9'-5"	10'-8"
800HS300-68	50	9'-11"	11'-0"	12'-5"	9'-11"	11'-0"	12'-5"	9'-11"	11'-0"	12'-5"	
800HS300-97	50	11'-1"	12'-0"	13'-8"	11'-1"	12'-0"	13'-8"	11'-1"	12'-0"	13'-8"	

## Exterior Span Chart (3.5" Flange)

### Exterior Structural Composite Table Notes

1. Deflections are computed using 0.7 times the listed wind load.
2. Header to be installed with open side facing up and a track fastened over the open end.
3. Table calculations are in accordance with the AISI S100-16/S2-20.
4. Headers are assumed to be connected using the corresponding standard clip and fastener pattern.
5. For deflection calculations, the effective moment of inertia, calculated at the maximum service load, was used.
6. The calculated flexural strength of the header was based upon  $L_b \leq L_u$ .
7. Header framing was calculated assuming a worse case condition of a sill height at ground.
8. This table is not applicable for load bearing walls but is applicable for a curtain wall application.
9. Tables were prepared using a 16" o.c. spacing from the jamb stud to the first adjacent typical wall stud.
10. Tabled widths marked with an \* (asterisk) require special engineering of the clip connection.
11. The strength analysis included separate bending and shear checks.
12. Unless connections are engineered separately, jambs must be the same or greater gauge and yield strength as the header.
13. Opening width is also limited by jamb considerations. See jamb table for limits.
14. Headers are assumed to be connected to the jamb with matching 14 gage 50 ksi MBA clips using 8 #10-16 screws.
15. Table to be used by qualified engineers only.

### Allowable header spans (Dead Load = 12psf , Wind Load = 25psf )

Wall Height (ft)	Section	Fy (ksi)	L/240			L/360			L/600		
			Opening Height (ft)			Opening Height (ft)			Opening Height (ft)		
			8ft	10ft	12ft	8ft	10ft	12ft	8ft	10ft	12ft
9	362HS350-54	50	10'-5"			10'-5"			10'-5"		
	362HS350-68	50	11'-9"			11'-9"			11'-9"		
	362HS350-97	50	13'-2"			13'-2"			13'-2"		
	600HS350-54	50	13'-10"			13'-9"			11'-7"		
	600HS350-68	50	15'-11"			15'-0"			12'-8"		
	600HS350-97	50	19'-3"			16'-10"			14'-3"		
	800HS350-54	50	15'-11"			15'-11"			14'-6"		
	800HS350-68	50	18'-3"			18'-3"			15'-9"		
	800HS350-97	50	19'-9"			19'-9"			17'-9"		
11	362HS350-54	50	8'-8"	9'-6"		8'-8"	8'-9"		7'-5"	7'-5"	
	362HS350-68	50	10'-1"	11'-0"		9'-7"	9'-7"		8'-1"	8'-1"	
	362HS350-97	50	12'-2"	12'-4"		10'-9"	10'-9"		9'-1"	9'-1"	
	600HS350-54	50	11'-1"	12'-9"		11'-1"	12'-9"		10'-10"	10'-10"	
	600HS350-68	50	12'-9"	14'-8"		12'-9"	14'-1"		11'-10"	11'-10"	
	600HS350-97	50	14'-8"	17'-9"		14'-8"	15'-9"		13'-4"	13'-4"	
	800HS350-54	50	12'-4"	14'-8"		12'-4"	14'-8"		12'-4"	13'-6"	
	800HS350-68	50	13'-10"	17'-2"		13'-10"	17'-2"		13'-10"	14'-9"	
	800HS350-97	50	15'-0"	19'-9"		15'-0"	19'-8"		15'-0"	16'-7"	
13	362HS350-54	50	7'-8"	8'-2"	8'-10"	7'-8"	8'-2"	8'-4"	7'-0"	7'-0"	7'-0"
	362HS350-68	50	8'-10"	9'-5"	10'-2"	8'-10"	9'-1"	9'-1"	7'-8"	7'-8"	7'-8"
	362HS350-97	50	10'-8"	11'-5"	11'-8"	10'-2"	10'-2"	10'-2"	8'-7"	8'-7"	8'-7"
	600HS350-54	50	9'-6"	10'-6"	11'-10"	9'-6"	10'-6"	11'-10"	9'-6"	10'-3"	10'-3"
	600HS350-68	50	10'-11"	12'-1"	13'-8"	10'-11"	12'-1"	13'-4"	10'-11"	11'-2"	11'-2"
	600HS350-97	50	12'-11"	14'-7"	16'-6"	12'-11"	14'-7"	14'-11"	12'-7"	12'-7"	12'-7"
	800HS350-54	50	10'-6"	11'-9"	13'-9"	10'-6"	11'-9"	13'-9"	10'-6"	11'-9"	12'-10"
	800HS350-68	50	12'-2"	13'-9"	16'-1"	12'-2"	13'-9"	16'-1"	12'-2"	13'-9"	14'-0"
	800HS350-97	50	13'-2"	15'-0"	19'-5"	13'-2"	15'-0"	18'-7"	13'-2"	15'-0"	15'-8"
15	362HS350-54	50	6'-11"	7'-3"	7'-8"	6'-11"	7'-3"	7'-8"	6'-8"	6'-8"	6'-8"
	362HS350-68	50	7'-11"	8'-4"	8'-11"	7'-11"	8'-4"	8'-8"	7'-4"	7'-4"	7'-4"
	362HS350-97	50	9'-7"	10'-2"	10'-10"	9'-7"	9'-8"	9'-8"	8'-2"	8'-2"	8'-2"
	600HS350-54	50	8'-5"	9'-1"	10'-0"	8'-5"	9'-1"	10'-0"	8'-5"	9'-1"	9'-9"
	600HS350-68	50	9'-9"	10'-6"	11'-6"	9'-9"	10'-6"	11'-6"	9'-9"	10'-6"	10'-8"
	600HS350-97	50	11'-8"	12'-8"	13'-10"	11'-8"	12'-8"	13'-10"	11'-8"	12'-0"	12'-0"
	800HS350-54	50	9'-3"	10'-1"	11'-3"	9'-3"	10'-1"	11'-3"	9'-3"	10'-1"	11'-3"
	800HS350-68	50	10'-9"	11'-9"	13'-1"	10'-9"	11'-9"	13'-1"	10'-9"	11'-9"	13'-1"
	800HS350-97	50	12'-2"	13'-2"	15'-0"	12'-2"	13'-2"	15'-0"	12'-2"	13'-2"	14'-11"

## Exterior Span Chart (3.0" Flange)

### Exterior Structural Composite Table Notes

1. Deflections are computed using 0.7 times the listed wind load.
2. Header to be installed with open side facing up and a track fastened over the open end.
3. Table calculations are in accordance with the AISI S100-16/S2-20.
4. Headers are assumed to be connected using the corresponding standard clip and fastener pattern.
5. For deflection calculations, the effective moment of inertia, calculated at the maximum service load, was used.
6. The calculated flexural strength of the header was based upon  $L_b \leq L_u$ .
7. Header framing was calculated assuming a worse case condition of a sill height at ground.
8. This table is not applicable for load bearing walls but is applicable for a curtain wall application.
9. Tables were prepared using a 16" o.c. spacing from the jamb stud to the first adjacent typical wall stud.
10. Tabled widths marked with an \* (asterisk) require special engineering of the clip connection.
11. The strength analysis included separate bending and shear checks.
12. Unless connections are engineered separately, jambs must be the same or greater gauge and yield strength as the header.
13. Opening width is also limited by jamb considerations. See jamb table for limits.
14. Headers are assumed to be connected to the jamb with matching 14 gage 50 ksi MBA clips using 8 #10-16 screws.
15. Table to be used by qualified engineers only.

### Allowable header spans (Dead Load = 12psf , Wind Load = 30psf )

Wall Height (ft)	Section	Fy (ksi)	L/240			L/360			L/600		
			Opening Height (ft)			Opening Height (ft)			Opening Height (ft)		
			8ft	10ft	12ft	8ft	10ft	12ft	8ft	10ft	12ft
9	362HS300-43	33	6'-8"			6'-8"			6'-8"		
	362HS300-54	50	9'-3"			9'-3"			9'-3"		
	362HS300-68	50	10'-8"			10'-8"			10'-8"		
	362HS300-97	50	11'-11"			11'-11"			11'-11"		
	600HS300-43	33	8'-11"			8'-11"			8'-11"		
	600HS300-54	50	12'-4"			12'-4"			10'-7"		
	600HS300-68	50	14'-3"			13'-8"			11'-7"		
	600HS300-97	50	17'-5"			15'-4"			12'-11"		
	800HS300-43	33	10'-3"			10'-3"			10'-3"		
	800HS300-54	50	14'-3"			14'-3"			13'-3"		
800HS300-68	50	16'-7"			16'-7"			14'-5"			
800HS300-97	50	18'-0"			18'-0"			16'-2"			
11	362HS300-43	33	5'-7"	6'-1"		5'-7"	6'-1"		5'-7"	6'-1"	
	362HS300-54	50	7'-9"	8'-5"		7'-9"	8'-0"		6'-9"	6'-9"	
	362HS300-68	50	9'-0"	9'-10"		8'-8"	8'-8"		7'-4"	7'-4"	
	362HS300-97	50	10'-11"	11'-1"		9'-9"	9'-9"		8'-2"	8'-2"	
	600HS300-43	33	7'-2"	8'-3"		7'-2"	8'-3"		7'-2"	8'-3"	
	600HS300-54	50	9'-10"	11'-4"		9'-10"	11'-4"		9'-10"	9'-11"	
	600HS300-68	50	11'-5"	13'-2"		11'-5"	12'-10"		10'-10"	10'-10"	
	600HS300-97	50	13'-4"	16'-1"		13'-4"	14'-4"		12'-1"	12'-1"	
	800HS300-43	33	8'-0"	9'-6"		8'-0"	9'-6"		8'-0"	9'-6"	
	800HS300-54	50	11'-1"	13'-2"		11'-1"	13'-2"		11'-1"	12'-5"	
800HS300-68	50	12'-7"	15'-5"		12'-7"	15'-5"		12'-7"	13'-6"		
800HS300-97	50	13'-8"	18'-0"		13'-8"	17'-11"		13'-8"	15'-1"		
13	362HS300-43	33	4'-11"	5'-3"	5'-8"	4'-11"	5'-3"	5'-8"	4'-11"	5'-3"	5'-8"
	362HS300-54	50	6'-9"	7'-3"	7'-10"	6'-9"	7'-3"	7'-7"	6'-5"	6'-5"	6'-5"
	362HS300-68	50	7'-10"	8'-5"	9'-1"	7'-10"	8'-3"	8'-3"	6'-11"	6'-11"	6'-11"
	362HS300-97	50	9'-7"	10'-3"	10'-6"	9'-2"	9'-2"	9'-2"	7'-9"	7'-9"	7'-9"
	600HS300-43	33	6'-1"	6'-9"	7'-8"	6'-1"	6'-9"	7'-8"	6'-1"	6'-9"	7'-8"
	600HS300-54	50	8'-6"	9'-4"	10'-7"	8'-6"	9'-4"	10'-7"	8'-6"	9'-4"	9'-5"
	600HS300-68	50	9'-9"	10'-10"	12'-3"	9'-9"	10'-10"	12'-1"	9'-9"	10'-3"	10'-3"
	600HS300-97	50	11'-9"	13'-2"	15'-0"	11'-9"	13'-2"	13'-6"	11'-5"	11'-5"	11'-5"
	800HS300-43	33	6'-9"	7'-7"	8'-11"	6'-9"	7'-7"	8'-11"	6'-9"	7'-7"	8'-11"
	800HS300-54	50	9'-4"	10'-6"	12'-4"	9'-4"	10'-6"	12'-4"	9'-4"	10'-6"	11'-3"
800HS300-68	50	10'-10"	12'-3"	14'-5"	10'-10"	12'-3"	14'-5"	10'-10"	12'-3"	12'-9"	
800HS300-97	50	12'-0"	13'-8"	17'-7"	12'-0"	13'-8"	16'-11"	12'-0"	13'-8"	14'-3"	
15	362HS300-43	33	4'-5"	4'-8"	4'-11"	4'-5"	4'-8"	4'-11"	4'-5"	4'-8"	4'-11"
	362HS300-54	50	6'-1"	6'-5"	6'-10"	6'-1"	6'-5"	6'-10"	6'-1"	6'-1"	6'-1"
	362HS300-68	50	7'-1"	7'-6"	7'-11"	7'-1"	7'-6"	7'-10"	6'-7"	6'-7"	6'-7"
	362HS300-97	50	8'-7"	9'-1"	9'-9"	8'-7"	8'-9"	8'-9"	7'-4"	7'-4"	7'-4"
	600HS300-43	33	5'-5"	5'-11"	6'-5"	5'-5"	5'-11"	6'-5"	5'-5"	5'-11"	6'-5"
	600HS300-54	50	7'-6"	8'-1"	8'-11"	7'-6"	8'-1"	8'-11"	7'-6"	8'-1"	8'-11"
	600HS300-68	50	8'-8"	9'-5"	10'-4"	8'-8"	9'-5"	10'-4"	8'-8"	9'-5"	9'-9"
	600HS300-97	50	10'-6"	11'-5"	12'-6"	10'-6"	11'-5"	12'-6"	10'-6"	10'-11"	10'-11"
	800HS300-43	33	5'-11"	6'-6"	7'-3"	5'-11"	6'-6"	7'-3"	5'-11"	6'-6"	7'-3"
	800HS300-54	50	8'-3"	9'-0"	10'-1"	8'-3"	9'-0"	10'-1"	8'-3"	9'-0"	10'-1"
800HS300-68	50	9'-7"	10'-6"	11'-9"	9'-7"	10'-6"	11'-9"	9'-7"	10'-6"	11'-9"	
800HS300-97	50	11'-1"	12'-0"	13'-8"	11'-1"	12'-0"	13'-8"	11'-1"	12'-0"	13'-7"	

## Exterior Span Chart (3.5" Flange)

### Exterior Structural Composite Table Notes

1. Deflections are computed using 0.7 times the listed wind load.
2. Header to be installed with open side facing up and a track fastened over the open end.
3. Table calculations are in accordance with the AISI S100-16/S2-20.
4. Headers are assumed to be connected using the corresponding standard clip and fastener pattern.
5. For deflection calculations, the effective moment of inertia, calculated at the maximum service load, was used.
6. The calculated flexural strength of the header was based upon  $L_b \leq L_u$ .
7. Header framing was calculated assuming a worse case condition of a sill height at ground.
8. This table is not applicable for load bearing walls but is applicable for a curtain wall application.
9. Tables were prepared using a 16" o.c. spacing from the jamb stud to the first adjacent typical wall stud.
10. Tabled widths marked with an \* (asterisk) require special engineering of the clip connection.
11. The strength analysis included separate bending and shear checks.
12. Unless connections are engineered separately, jambs must be the same or greater gauge and yield strength as the header.
13. Opening width is also limited by jamb considerations. See jamb table for limits.
14. Headers are assumed to be connected to the jamb with matching 14 gage 50 ksi MBA clips using 8 #10-16 screws.
15. Table to be used by qualified engineers only.

### Allowable header spans (Dead Load = 12psf , Wind Load = 30psf )

Wall Height (ft)	Section	Fy (ksi)	L/240			L/360			L/600		
			Opening Height (ft)			Opening Height (ft)			Opening Height (ft)		
			8ft	10ft	12ft	8ft	10ft	12ft	8ft	10ft	12ft
9	362HS350-54	50	9'-7"			9'-7"			9'-7"		
	362HS350-68	50	11'-1"			11'-1"			11'-1"		
	362HS350-97	50	12'-5"			12'-5"			12'-5"		
	600HS350-54	50	12'-10"			12'-10"			10'-11"		
	600HS350-68	50	14'-9"			14'-2"			11'-11"		
	600HS350-97	50	17'-10"			15'-10"			13'-5"		
	800HS350-54	50	14'-10"			14'-10"			13'-7"		
	800HS350-68	50	17'-4"			17'-4"			14'-10"		
800HS350-97	50	19'-9"			19'-9"			16'-8"			
11	362HS350-54	50	8'-1"	8'-9"		8'-1"	8'-3"		6'-11"	6'-11"	
	362HS350-68	50	9'-4"	10'-1"		9'-0"	9'-0"		7'-7"	7'-7"	
	362HS350-97	50	11'-4"	11'-7"		10'-1"	10'-1"		8'-6"	8'-6"	
	600HS350-54	50	10'-5"	11'-9"		10'-5"	11'-9"		10'-2"	10'-2"	
	600HS350-68	50	12'-0"	13'-7"		12'-0"	13'-3"		11'-2"	11'-2"	
	600HS350-97	50	14'-6"	16'-5"		14'-6"	14'-10"		12'-6"	12'-6"	
	800HS350-54	50	11'-9"	13'-8"		11'-9"	13'-8"		11'-9"	12'-9"	
	800HS350-68	50	13'-8"	16'-0"		13'-8"	16'-0"		13'-8"	13'-11"	
800HS350-97	50	15'-0"	19'-3"		15'-0"	18'-6"		15'-0"	15'-7"		
13	362HS350-54	50	7'-2"	7'-7"	8'-1"	7'-2"	7'-7"	7'-10"	6'-7"	6'-7"	6'-7"
	362HS350-68	50	8'-3"	8'-9"	9'-4"	8'-3"	8'-7"	8'-7"	7'-2"	7'-2"	7'-2"
	362HS350-97	50	10'-0"	10'-8"	10'-11"	9'-7"	9'-7"	9'-7"	8'-1"	8'-1"	8'-1"
	600HS350-54	50	9'-0"	9'-10"	11'-0"	9'-0"	9'-10"	11'-0"	9'-0"	9'-8"	9'-8"
	600HS350-68	50	10'-4"	11'-4"	12'-7"	10'-4"	11'-4"	12'-6"	10'-4"	10'-6"	10'-6"
	600HS350-97	50	12'-6"	13'-8"	15'-3"	12'-6"	13'-8"	14'-0"	11'-10"	11'-10"	11'-10"
	800HS350-54	50	10'-0"	11'-1"	12'-9"	10'-0"	11'-1"	12'-9"	10'-0"	11'-1"	12'-0"
	800HS350-68	50	11'-7"	13'-0"	14'-11"	11'-7"	13'-0"	14'-11"	11'-7"	13'-0"	13'-2"
800HS350-97	50	13'-2"	15'-0"	18'-0"	13'-2"	15'-0"	17'-6"	13'-2"	14'-9"	14'-9"	
15	362HS350-54	50	6'-6"	6'-9"	7'-2"	6'-6"	6'-9"	7'-2"	6'-3"	6'-3"	6'-3"
	362HS350-68	50	7'-6"	7'-10"	8'-3"	7'-6"	7'-10"	8'-2"	6'-10"	6'-10"	6'-10"
	362HS350-97	50	9'-1"	9'-6"	10'-0"	9'-1"	9'-1"	9'-1"	7'-8"	7'-8"	7'-8"
	600HS350-54	50	8'-1"	8'-7"	9'-4"	8'-1"	8'-7"	9'-4"	8'-1"	8'-7"	9'-2"
	600HS350-68	50	9'-3"	9'-11"	10'-9"	9'-3"	9'-11"	10'-9"	9'-3"	9'-11"	10'-1"
	600HS350-97	50	11'-2"	11'-11"	13'-0"	11'-2"	11'-11"	13'-0"	11'-2"	11'-3"	11'-3"
	800HS350-54	50	8'-10"	9'-7"	10'-7"	8'-10"	9'-7"	10'-7"	8'-10"	9'-7"	10'-7"
	800HS350-68	50	10'-3"	11'-2"	12'-4"	10'-3"	11'-2"	12'-4"	10'-3"	11'-2"	12'-4"
800HS350-97	50	12'-2"	13'-2"	14'-11"	12'-2"	13'-2"	14'-11"	12'-2"	13'-2"	14'-1"	

## Allowable Opening Widths (3.0" Flange)

### Interior Structural Composite Table Notes

1. Deflections are computed using 1.0 times the listed wind load.
2. Header to be installed with open side facing up.
3. Minimum opening height based on 36 inches (center of wall). This table is also applicable for door openings.
4. Limitations to opening widths are 16'-0" for 3-5/8" members and 20'-0" for 6" & 8" members.
5. Table calculations are in accordance with the AISI S100-16/S2-20.
6. Calculated flexural strength of the jamb based upon  $L_b \leq L_u$ .
7. This table is applicable for a curtain wall application, but it is not intended for load bearing walls.
8. Tables were prepared using a 16" o.c. spacing from the jamb stud to the first adjacent typical wall stud.
9. Tabled widths marked with an \* (asterisk) require web stiffening at each end of the jamb. Web crippling check uses 1" of bearing length.
10. The strength analysis included separate bending and shear checks plus combined bending and shear.
11. Unless connections are engineered separately, jambs must be the same gauge and strength as the header.
12. Opening width is also limited by header and clip considerations. See clip and header table for limits.
13. Headers are assumed to be connected to the jamb with matching 14 gage 50 ksi MBA clips using 8 #10-16 screws.
14. Table to be used by qualified engineers only.

### Single Framing Used as Interior Jamb Studs

Wall Height (ft)	Section	F <sub>y</sub> (ksi)	5psf			10psf			15psf		
			L/240	L/360	L/600	L/240	L/360	L/600	L/240	L/360	L/600
9	362JS300-43	33	16'-0"	16'-0"	16'-0"	16'-0"	13'-2"	7'-3"	10'-10"	8'-3"	4'-4"
	362JS300-54	50	16'-0"	16'-0"	16'-0"	16'-0"	16'-0"	9'-5"	16'-0"	10'-8"	5'-9"
	362JS300-68	50	16'-0"	16'-0"	16'-0"	16'-0"	16'-0"	12'-6"	16'-0"	14'-1"	7'-10"
	362JS300-97	50	16'-0"	16'-0"	16'-0"	16'-0"	16'-0"	16'-0"	16'-0"	16'-0"	11'-5"
	600JS300-43	33	16'-0"	16'-0"	16'-0"	16'-0"	16'-0"	16'-0"	16'-0"	16'-0"	16'-0"
	600JS300-54	50	20'-0"	20'-0"	20'-0"	20'-0"	20'-0"	20'-0"	20'-0"	20'-0"	20'-0"
	600JS300-68	50	20'-0"	20'-0"	20'-0"	20'-0"	20'-0"	20'-0"	20'-0"	20'-0"	20'-0"
	600JS300-97	50	20'-0"	20'-0"	20'-0"	20'-0"	20'-0"	20'-0"	20'-0"	20'-0"	20'-0"
	800JS300-43	33	16'-0"	16'-0"	16'-0"	16'-0"	16'-0"	16'-0"	16'-0"	16'-0"	16'-0"
	800JS300-54	50	20'-0"	20'-0"	20'-0"	20'-0"	20'-0"	20'-0"	20'-0"	20'-0"	20'-0"
11	362JS300-43	33	16'-0"	14'-5"	8'-1"	10'-5"	6'-6"	3'-3"	6'-6"	3'-10"	
	362JS300-54	50	16'-0"	16'-0"	10'-5"	13'-4"	8'-5"	4'-5"	8'-5"	5'-1"	
	362JS300-68	50	16'-0"	16'-0"	13'-9"	16'-0"	11'-2"	6'-1"	11'-2"	7'-0"	3'-7"
	362JS300-97	50	16'-0"	16'-0"	16'-0"	16'-0"	16'-0"	9'-1"	16'-0"	10'-3"	5'-6"
	600JS300-43	33	16'-0"	16'-0"	16'-0"	16'-0"	16'-0"	13'-6"	13'-10"	13'-10"	8'-6"
	600JS300-54	50	20'-0"	20'-0"	20'-0"	20'-0"	20'-0"	17'-3"	20'-0"	19'-4"	11'-0"
	600JS300-68	50	20'-0"	20'-0"	20'-0"	20'-0"	20'-0"	20'-0"	20'-0"	20'-0"	14'-7"
	600JS300-97	50	20'-0"	20'-0"	20'-0"	20'-0"	20'-0"	20'-0"	20'-0"	20'-0"	20'-0"
	800JS300-43	33	16'-0"	16'-0"	16'-0"	16'-0"	16'-0"	16'-0"	16'-0"	16'-0"	16'-0"
	800JS300-54	50	20'-0"	20'-0"	20'-0"	20'-0"	20'-0"	20'-0"	20'-0"	20'-0"	20'-0"
13	362JS300-43	33	13'-0"	8'-2"	4'-4"	5'-9"	3'-4"		3'-4"		
	362JS300-54	50	16'-0"	10'-6"	5'-9"	7'-6"	4'-6"		4'-6"		
	362JS300-68	50	16'-0"	13'-11"	7'-9"	10'-1"	6'-3"	3'-2"	6'-3"	3'-8"	
	362JS300-97	50	16'-0"	16'-0"	11'-4"	14'-6"	9'-2"	4'-11"	9'-2"	5'-7"	
	600JS300-43	33	16'-0"	16'-0"	16'-0"	14'-9"	13'-9"	7'-8"	9'-5"	8'-8"	4'-7"
	600JS300-54	50	20'-0"	20'-0"	20'-0"	20'-0"	17'-6"	9'-11"	17'-6"	11'-2"	6'-1"
	600JS300-68	50	20'-0"	20'-0"	20'-0"	20'-0"	20'-0"	13'-2"	20'-0"	14'-10"	8'-3"
	600JS300-97	50	20'-0"	20'-0"	20'-0"	20'-0"	20'-0"	19'-0"	20'-0"	20'-0"	12'-2"
	800JS300-43	33	16'-0"	16'-0"	16'-0"	16'-0"	16'-0"	16'-0"	12'-11"	12'-11"	10'-5"
	800JS300-54	50	20'-0"	20'-0"	20'-0"	20'-0"	20'-0"	20'-0"	20'-0"	20'-0"	13'-5"
15	362JS300-43	33	8'-0"	4'-10"		3'-3"					
	362JS300-54	50	10'-4"	6'-4"	3'-3"	4'-5"					
	362JS300-68	50	13'-8"	8'-7"	4'-7"	6'-1"			3'-7"		
	362JS300-97	50	16'-0"	12'-6"	6'-11"	9'-0"	5'-6"		5'-6"	3'-2"	
	600JS300-43	33	16'-0"	16'-0"	10'-5"	10'-8"	8'-6"	4'-6"	6'-8"	5'-2"	
	600JS300-54	50	20'-0"	20'-0"	13'-5"	17'-2"	10'-11"	6'-0"	10'-11"	6'-10"	3'-6"
	600JS300-68	50	20'-0"	20'-0"	17'-9"	20'-0"	14'-6"	8'-1"	14'-6"	9'-2"	4'-11"
	600JS300-97	50	20'-0"	20'-0"	20'-0"	20'-0"	20'-0"	11'-11"	20'-0"	13'-5"	7'-5"
	800JS300-43	33	16'-0"	16'-0"	16'-0"	14'-10"	14'-10"	10'-2"	9'-6"	9'-6"	6'-3"
	800JS300-54	50	20'-0"	20'-0"	20'-0"	20'-0"	20'-0"	13'-1"	19'-7"	14'-9"	8'-3"

## Allowable Opening Widths (3.5" Flange)

### Interior Structural Composite Table Notes

1. Deflections are computed using 1.0 times the listed wind load.
2. Header to be installed with open side facing up.
3. Minimum opening height based on 36 inches (center of wall). This table is also applicable for door openings.
4. Limitations to opening widths are 16'-0" for 3-5/8" members and 20'-0" for 6" & 8" members.
5. Table calculations are in accordance with the AISI S100-16/S2-20.
6. Calculated flexural strength of the jamb based upon  $L_b \leq L_u$ .
7. This table is applicable for a curtain wall application, but it is not intended for load bearing walls.
8. Tables were prepared using a 16" o.c. spacing from the jamb stud to the first adjacent typical wall stud.
9. Tabled widths marked with an \* (asterisk) require web stiffening at each end of the jamb. Web crippling check uses 1" of bearing length.
10. The strength analysis included separate bending and shear checks plus combined bending and shear.
11. Unless connections are engineered separately, jambs must be the same gauge and strength as the header.
12. Opening width is also limited by header and clip considerations. See clip and header table for limits.
13. Headers are assumed to be connected to the jamb with matching 14 gage 50 ksi MBA clips using 8 #10-16 screws.
14. Table to be used by qualified engineers only.

### Single Framing Used as Interior Jamb Studs

Wall Height (ft)	Section	Fy (ksi)	5psf			10psf			15psf		
			L/240	L/360	L/600	L/240	L/360	L/600	L/240	L/360	L/600
9	362JS350-54	50	16'-0"	16'-0"	16'-0"	16'-0"	16'-0"	10'-5"	16'-0"	11'-9"	6'-6"
	362JS350-68	50	16'-0"	16'-0"	16'-0"	16'-0"	16'-0"	14'-2"	16'-0"	15'-11"	8'-11"
	362JS350-97	50	16'-0"	16'-0"	16'-0"	16'-0"	16'-0"	16'-0"	16'-0"	16'-0"	13'-1"
	600JS350-54	50	20'-0"	20'-0"	20'-0"	20'-0"	20'-0"	20'-0"	20'-0"	20'-0"	20'-0"
	600JS350-68	50	20'-0"	20'-0"	20'-0"	20'-0"	20'-0"	20'-0"	20'-0"	20'-0"	20'-0"
	600JS350-97	50	20'-0"	20'-0"	20'-0"	20'-0"	20'-0"	20'-0"	20'-0"	20'-0"	20'-0"
	800JS350-54	50	20'-0"	20'-0"	20'-0"	20'-0"	20'-0"	20'-0"	20'-0"	20'-0"	20'-0"
	800JS350-68	50	20'-0"	20'-0"	20'-0"	20'-0"	20'-0"	20'-0"	20'-0"	20'-0"	20'-0"
	800JS350-97	50	20'-0"	20'-0"	20'-0"	20'-0"	20'-0"	20'-0"	20'-0"	20'-0"	20'-0"
11	362JS350-54	50	16'-0"	16'-0"	11'-6"	14'-9"	9'-4"	5'-0"	9'-4"	5'-9"	
	362JS350-68	50	16'-0"	16'-0"	15'-7"	16'-0"	12'-9"	7'-0"	12'-9"	8'-0"	4'-2"
	362JS350-97	50	16'-0"	16'-0"	16'-0"	16'-0"	16'-0"	10'-5"	16'-0"	11'-9"	6'-5"
	600JS350-54	50	20'-0"	20'-0"	20'-0"	20'-0"	20'-0"	18'-10"	20'-0"	20'-0"	12'-1"
	600JS350-68	50	20'-0"	20'-0"	20'-0"	20'-0"	20'-0"	20'-0"	20'-0"	20'-0"	16'-3"
	600JS350-97	50	20'-0"	20'-0"	20'-0"	20'-0"	20'-0"	20'-0"	20'-0"	20'-0"	20'-0"
	800JS350-54	50	20'-0"	20'-0"	20'-0"	20'-0"	20'-0"	20'-0"	20'-0"	20'-0"	20'-0"
	800JS350-68	50	20'-0"	20'-0"	20'-0"	20'-0"	20'-0"	20'-0"	20'-0"	20'-0"	20'-0"
	800JS350-97	50	20'-0"	20'-0"	20'-0"	20'-0"	20'-0"	20'-0"	20'-0"	20'-0"	20'-0"
13	362JS350-54	50	16'-0"	11'-8"	6'-5"	8'-5"	5'-1"		5'-1"		
	362JS350-68	50	16'-0"	15'-9"	8'-10"	11'-5"	7'-2"	3'-8"	7'-2"	4'-3"	
	362JS350-97	50	16'-0"	16'-0"	13'-0"	16'-0"	10'-7"	5'-9"	10'-7"	6'-7"	3'-4"
	600JS350-54	50	20'-0"	20'-0"	20'-0"	20'-0"	19'-1"	10'-10"	19'-1"	12'-3"	6'-9"
	600JS350-68	50	20'-0"	20'-0"	20'-0"	20'-0"	20'-0"	14'-8"	20'-0"	16'-5"	9'-3"
	600JS350-97	50	20'-0"	20'-0"	20'-0"	20'-0"	20'-0"	20'-0"	20'-0"	20'-0"	13'-8"
	800JS350-54	50	20'-0"	20'-0"	20'-0"	20'-0"	20'-0"	20'-0"	20'-0"	20'-0"	14'-6"
	800JS350-68	50	20'-0"	20'-0"	20'-0"	20'-0"	20'-0"	20'-0"	20'-0"	20'-0"	19'-4"
	800JS350-97	50	20'-0"	20'-0"	20'-0"	20'-0"	20'-0"	20'-0"	20'-0"	20'-0"	20'-0"
15	362JS350-54	50	11'-5"	7'-1"	3'-8"	5'-0"					
	362JS350-68	50	15'-6"	9'-10"	5'-3"	7'-0"	4'-2"		4'-2"		
	362JS350-97	50	16'-0"	14'-4"	8'-0"	10'-4"	6'-5"	3'-3"	6'-5"	3'-9"	
	600JS350-54	50	20'-0"	20'-0"	14'-8"	18'-9"	12'-0"	6'-7"	12'-0"	7'-6"	3'-11"
	600JS350-68	50	20'-0"	20'-0"	19'-8"	20'-0"	16'-1"	9'-1"	16'-1"	10'-3"	5'-6"
	600JS350-97	50	20'-0"	20'-0"	20'-0"	20'-0"	20'-0"	13'-5"	20'-0"	15'-1"	8'-5"
	800JS350-54	50	20'-0"	20'-0"	20'-0"	20'-0"	20'-0"	14'-3"	20'-0"	16'-0"	9'-0"
	800JS350-68	50	20'-0"	20'-0"	20'-0"	20'-0"	20'-0"	18'-11"	20'-0"	20'-0"	12'-1"
	800JS350-97	50	20'-0"	20'-0"	20'-0"	20'-0"	20'-0"	20'-0"	20'-0"	20'-0"	17'-9"

## Allowable Opening Widths (3.0" Flange)

### Interior Structural Composite Table Notes

1. Deflections are computed using 0.7 times the listed wind load.
2. Header to be installed with open side facing up.
3. Minimum opening height based on 36 inches (center of wall). This table is also applicable for door openings.
4. Limitations to opening widths are 16'-0" for 3-5/8" members and 20'-0" for 6" & 8" members.
5. Table calculations are in accordance with the AISI S100-16/S2-20.
6. Calculated flexural strength of the jamb based upon  $L_b \leq L_u$ .
7. This table is applicable for a curtain wall application, but it is not intended for load bearing walls.
8. Tables were prepared using a 16" o.c. spacing from the jamb stud to the first adjacent typical wall stud.
9. Tabled widths marked with an \* (asterisk) require web stiffening at each end of the jamb. Web crippling check uses 1" of bearing length.
10. The strength analysis included separate bending and shear checks plus combined bending and shear.
11. Unless connections are engineered separately, jambs must be the same gauge and strength as the header.
12. Opening width is also limited by header and clip considerations. See clip and header table for limits.
13. Headers are assumed to be connected to the jamb with matching 14 gage 50 ksi MBA clips using 8 #10-16 screws.
14. Table to be used by qualified engineers only.

### Single Framing Used as Exterior Jamb Studs

Wall Height (ft)	Section	Fy (ksi)	20psf			25psf			30psf		
			L/240	L/360	L/600	L/240	L/360	L/600	L/240	L/360	L/600
9	362JS300-43	33	7'-9"*	7'-9"*	4'-9"	5'-10"*	5'-10"*	3'-6"	4'-8"*	4'-8"*	
	362JS300-54	50	16'-0"	11'-6"	6'-4"	12'-7"	8'-11"	4'-9"	10'-3"	7'-2"	3'-8"
	362JS300-68	50	16'-0"	15'-2"	8'-6"	16'-0"	11'-10"	6'-6"	14'-7"	9'-7"	5'-2"
	362JS300-97	50	16'-0"	16'-0"	12'-4"	16'-0"	16'-0"	9'-7"	16'-0"	13'-11"	7'-9"
	600JS300-43	33	15'-10"*	15'-10"*	15'-10"*	12'-5"*	12'-5"*	12'-5"*	10'-2"*	10'-2"*	10'-2"*
	600JS300-54	50	20'-0"*	20'-0"*	20'-0"*	20'-0"*	20'-0"*	18'-3"*	20'-0"*	20'-0"*	14'-11"*
	600JS300-68	50	20'-0"	20'-0"	20'-0"	20'-0"	20'-0"	20'-0"	20'-0"*	20'-0"*	19'-8"*
	600JS300-97	50	20'-0"	20'-0"	20'-0"	20'-0"	20'-0"	20'-0"	20'-0"*	20'-0"*	20'-0"
	800JS300-43	33	16'-0"*	16'-0"*	16'-0"*	15'-6"*	15'-6"*	15'-6"*	12'-9"*	12'-9"*	12'-9"*
	800JS300-54	50	20'-0"*	20'-0"*	20'-0"*	20'-0"*	20'-0"*	20'-0"*	20'-0"*	20'-0"*	20'-0"*
11	362JS300-43	33	4'-6"	4'-2"		3'-3"	3'-1"				
	362JS300-54	50	9'-1"	5'-7"		7'-0"	4'-2"		5'-7"	3'-3"	
	362JS300-68	50	12'-1"	7'-7"	3'-11"	9'-5"	5'-9"		7'-7"	4'-7"	
	362JS300-97	50	16'-0"	11'-1"	6'-0"	13'-7"	8'-7"	4'-6"	11'-1"	6'-11"	3'-6"
	600JS300-43	33	10'-0"*	10'-0"*	9'-3"*	7'-9"*	7'-9"*	7'-1"*	6'-3"*	6'-3"*	5'-8"*
	600JS300-54	50	20'-0"*	20'-0"*	11'-11"	16'-0"*	16'-0"*	9'-3"	13'-2"*	13'-2"*	7'-5"
	600JS300-68	50	20'-0"	20'-0"	15'-0"	20'-0"*	20'-0"*	12'-4"	18'-6"*	17'-8"*	10'-0"
	600JS300-97	50	20'-0"	20'-0"	20'-0"	20'-0"	20'-0"	17'-9"	20'-0"	20'-0"	14'-6"
	800JS300-43	33	13'-4"*	13'-4"*	13'-4"*	10'-5"*	10'-5"*	10'-5"*	8'-6"*	8'-6"*	8'-6"*
	800JS300-54	50	20'-0"*	20'-0"*	20'-0"*	20'-0"*	20'-0"*	19'-6"*	17'-8"*	17'-8"*	16'-0"*
13	362JS300-43	33									
	362JS300-54	50	4'-11"			3'-8"					
	362JS300-68	50	6'-9"	4'-0"		5'-1"			4'-0"		
	362JS300-97	50	9'-11"	6'-2"	3'-1"	7'-8"	4'-7"		6'-2"	3'-7"	
	600JS300-43	33	6'-9"*	6'-9"*	5'-0"*	5'-1"*	5'-1"*	3'-9"*	4'-0"*	4'-0"*	
	600JS300-54	50	14'-1"*	12'-1"	6'-8"	11'-0"*	9'-4"	5'-0"	8'-11"*	7'-7"	3'-11"
	600JS300-68	50	19'-8"	16'-0"	9'-0"	15'-5"	12'-6"	6'-11"	12'-8"	10'-2"	5'-6"
	600JS300-97	50	20'-0"	20'-0"	13'-1"	20'-0"	18'-0"	10'-2"	19'-10"	14'-9"	8'-3"
	800JS300-43	33	9'-5"*	9'-5"*	9'-5"*	7'-3"*	7'-3"*	7'-3"*	5'-10"*	5'-10"*	5'-10"*
	800JS300-54	50	19'-5"*	19'-5"*	14'-5"*	15'-3"*	15'-3"*	11'-3"*	12'-6"*	12'-6"*	9'-2"*
15	362JS300-43	33									
	362JS300-54	50									
	362JS300-68	50	3'-11"								
	362JS300-97	50	6'-0"	3'-6"		4'-6"			3'-6"		
	600JS300-43	33	4'-8"*	4'-8"*		3'-6"*	3'-6"*				
	600JS300-54	50	10'-2"	7'-5"	3'-10"	7'-10"	5'-7"		6'-4"	4'-5"	
	600JS300-68	50	14'-3"	9'-11"	5'-4"	11'-2"	7'-8"	4'-0"	9'-1"	6'-1"	3'-1"
	600JS300-97	50	20'-0"	14'-5"	8'-1"	17'-7"	11'-3"	6'-2"	14'-5"	9'-2"	4'-10"
	800JS300-43	33	6'-10"*	6'-10"*	6'-10"*	5'-2"*	5'-2"*	5'-2"*	4'-1"*	4'-1"*	4'-1"*
	800JS300-54	50	14'-5"*	14'-5"*	8'-11"	11'-3"*	11'-3"*	6'-10"	9'-2"*	9'-2"*	5'-5"
800JS300-68	50	20'-0"*	20'-0"*	11'-10"	16'-8"*	16'-4"*	9'-2"	13'-8"*	13'-4"*	7'-5"	
800JS300-97	50	20'-0"	20'-0"	17'-3"	20'-0"	20'-0"	13'-6"	20'-0"	19'-4"	11'-0"	

## Allowable Opening Widths (3.0" Flange)

### Interior Structural Composite Table Notes

1. Deflections are computed using 0.7 times the listed wind load.
2. Header to be installed with open side facing up.
3. Minimum opening height based on 36 inches (center of wall). This table is also applicable for door openings.
4. Limitations to opening widths are 16'-0" for 3-5/8" members and 20'-0" for 6" & 8" members.
5. Table calculations are in accordance with the AISI S100-16/S2-20.
6. Calculated flexural strength of the jamb based upon  $L_b \leq L_u$ .
7. This table is applicable for a curtain wall application, but it is not intended for load bearing walls.
8. Tables were prepared using a 16" o.c. spacing from the jamb stud to the first adjacent typical wall stud.
9. Tabled widths marked with an \* (asterisk) require web stiffening at each end of the jamb. Web crippling check uses 1" of bearing length.
10. The strength analysis included separate bending and shear checks plus combined bending and shear.
11. Unless connections are engineered separately, jambs must be the same gauge and strength as the header.
12. Opening width is also limited by header and clip considerations. See clip and header table for limits.
13. Headers are assumed to be connected to the jamb with matching 14 gage 50 ksi MBA clips using 8 #10-16 screws.
14. Table to be used by qualified engineers only.

### Single Framing Used as Exterior Jamb Studs

Wall Height (ft)	Section	Fy (ksi)	5psf			10psf			15psf		
			L/240	L/360	L/600	L/240	L/360	L/600	L/240	L/360	L/600
9	362JS350-54	50	16'-0"	12'-9"	7'-0"	13'-4"	9'-11"	5'-4"	10'-10"	8'-0"	4'-2"
	362JS350-68	50	16'-0"	16'-0"	9'-8"	16'-0"	13'-5"	7'-5"	15'-2"	10'-11"	5'-11"
	362JS350-97	50	16'-0"	16'-0"	14'-2"	16'-0"	16'-0"	11'-0"	16'-0"	15'-11"	8'-11"
	600JS350-54	50	20'-0"*	20'-0"*	20'-0"*	20'-0"*	20'-0"*	19'-10"*	20'-0"*	20'-0"*	16'-3"*
	600JS350-68	50	20'-0"	20'-0"	20'-0"	20'-0"	20'-0"	20'-0"	20'-0"	20'-0"	20'-0"
	600JS350-97	50	20'-0"	20'-0"	20'-0"	20'-0"	20'-0"	20'-0"	20'-0"	20'-0"	20'-0"
	800JS350-54	50	20'-0"*	20'-0"*	20'-0"*	20'-0"*	20'-0"*	20'-0"*	20'-0"*	20'-0"*	20'-0"*
	800JS350-68	50	20'-0"	20'-0"	20'-0"	20'-0"	20'-0"	20'-0"	20'-0"	20'-0"	20'-0"
	800JS350-97	50	20'-0"	20'-0"	20'-0"	20'-0"	20'-0"	20'-0"	20'-0"	20'-0"	20'-0"
11	362JS350-54	50	10'-1"	6'-3"	3'-2"	7'-9"	4'-8"		6'-3"	3'-8"	
	362JS350-68	50	13'-9"	8'-8"	4'-7"	10'-8"	6'-7"	3'-4"	8'-8"	5'-3"	
	362JS350-97	50	16'-0"	12'-8"	7'-0"	15'-7"	9'-10"	5'-4"	12'-8"	8'-0"	4'-2"
	600JS350-54	50	20'-0"*	20'-0"*	13'-0"	16'-9"*	16'-9"*	10'-1"	13'-9"*	13'-9"*	8'-2"
	600JS350-68	50	20'-0"	20'-0"	17'-6"	20'-0"*	20'-0"*	13'-8"	19'-1"*	19'-1"*	11'-2"
	600JS350-97	50	20'-0"	20'-0"	20'-0"	20'-0"	20'-0"	19'-11"	20'-0"	20'-0"	16'-4"
	800JS350-54	50	20'-0"*	20'-0"*	20'-0"*	20'-0"*	20'-0"*	20'-0"*	18'-0"*	18'-0"*	17'-4"*
	800JS350-68	50	20'-0"	20'-0"	20'-0"	20'-0"	20'-0"	20'-0"	20'-0"	20'-0"	20'-0"
	800JS350-97	50	20'-0"	20'-0"	20'-0"	20'-0"	20'-0"	20'-0"	20'-0"	20'-0"	20'-0"
13	362JS350-54	50	5'-7"	3'-2"		4'-2"			3'-2"		
	362JS350-68	50	7'-9"	4'-8"		5'-11"	3'-5"		4'-8"		
	362JS350-97	50	11'-5"	7'-2"	3'-8"	8'-10"	5'-5"		7'-2"	4'-3"	
	600JS350-54	50	14'-9"*	13'-2"*	7'-4"	11'-6"*	10'-3"*	5'-7"	9'-5"*	8'-4"*	4'-5"
	600JS350-68	50	20'-0"	17'-9"	10'-0"	15'-11"	13'-11"	7'-9"	13'-1"	11'-4"	6'-2"
	600JS350-97	50	20'-0"	20'-0"	14'-9"	20'-0"	20'-0"	11'-6"	20'-0"	16'-7"	9'-4"
	800JS350-54	50	19'-10"*	19'-10"*	15'-8"*	15'-8"*	15'-8"*	12'-3"*	12'-10"*	12'-10"*	9'-11"*
	800JS350-68	50	20'-0"*	20'-0"*	20'-0"*	20'-0"*	20'-0"*	16'-4"*	19'-3"*	19'-3"*	13'-4"*
	800JS350-97	50	20'-0"	20'-0"	20'-0"	20'-0"	20'-0"	20'-0"	20'-0"	20'-0"	19'-6"
15	362JS350-54	50	3'-1"								
	362JS350-68	50	4'-7"			3'-4"					
	362JS350-97	50	7'-0"	4'-2"		5'-3"	3'-0"		4'-2"		
	600JS350-54	50	10'-8"	8'-1"	4'-3"	8'-3"*	6'-2"	3'-1"	6'-8"*	4'-11"	
	600JS350-68	50	14'-9"	11'-1"	6'-1"	11'-6"	8'-7"	4'-6"	9'-4"	6'-11"	3'-6"
	600JS350-97	50	20'-0"	16'-3"	9'-2"	17'-8"	12'-9"	7'-0"	14'-6"	10'-4"	5'-7"
	800JS350-54	50	14'-9"*	14'-9"*	9'-9"	11'-7"*	11'-7"*	7'-6"	9'-5"*	9'-5"*	6'-0"
	800JS350-68	50	20'-0"*	20'-0"*	13'-1"	17'-2"*	17'-2"*	10'-2"	14'-1"*	14'-1"*	8'-3"
	800JS350-97	50	20'-0"	20'-0"	19'-2"	20'-0"	20'-0"	15'-0"	20'-0"	20'-0"	12'-3"

## Furring Channel

Furring Channel may be used for furring masonry walls and ceiling assemblies or in any other typical wall furring or cross-furring or framing application. Furring channel is available in 7/8" and 1-1/2" heights. Bearing surface is 1-1/4". Furring channel is available in 18, 27, 30 and 43 mil thicknesses (25-18ga.). Custom furring channel is available on request.

### Member Depth:

(Example: 1-1/2" = 150 x 1/100 inches)

All member depths are taken in 1/100 inches. For all "T" sections member depth is the inside to inside dimension.

### Flange Width:

(Example: 1-1/4" = 1.25" = 125 x 1/100 inches)

All flange widths are taken in 1/100 inches.

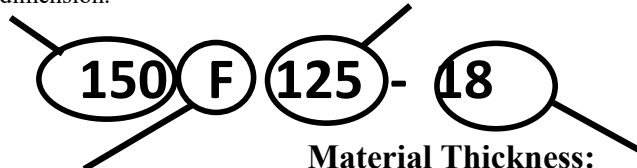

### Style:

(Example: Furring Channel Section = F)

The alpha character utilized by the designation system is:

F = Furring Channel Sections

### Material Thickness:

(Example: 0.018 in. = 18 mils; 1 mil = 1/100 in.)

Material thickness is the minimum base metal thickness in mils.

Minimum base metal thickness represents 95% of the design thickness.

## Steel Thickness

Mils	Gauge	Thickness (in)	
		Design	Minimum <sup>1</sup>
18	25	0.0188	0.0179
30	20	0.0312	0.0296
43	18	0.0451	0.0428

<sup>1</sup> Minimum Thickness represents 95% of the design thickness and is the minimum acceptable thickness delivered to the job site based on AISI S100-16/S2-20.

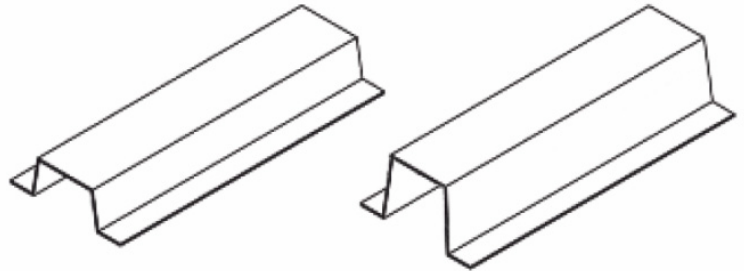

## General Notes

1. Calculated properties are based on AISI S100-16/S2-20 "North American Specification for Design of Cold-Formed Steel Structural Members."
2. Structural framing members have a protective coating conforming to ASTM C 955.
3. Drywall framing members have a protective coating conforming to ASTM spec A 653/A 653M, G-40 min, or equivalent corrosion resistance.
4. Reference ASTM specification A 1003/A 1003 M table 1 for the universe of allowable coatings for light gauge steel framing.
5. All delivered material must be kept dry, preferably by being stored inside a building under a roof. If it is necessary to store material outside, it must be stacked off the ground, properly supported on a level platform, and fully protected from the weather. Reference ASTM C 754 section 8 and ASTM C 1007 section 4.
6. Drywall framing [nonstructural 25 gauge, 22 gauge and 20 gauge] is not permitted in load bearing (i.e. axial load greater than 200 lbs.) or exterior applications (i.e. transverse load greater than 10 PSF). Reference ASTM C 645 section 3.2.2.

## Furring Channel Properties

### Furring Channel Section Properties

Section	Design Thickness <sup>1</sup> (in)	Gross Properties					Effective Properties <sup>3</sup> (33ksi)		
		Area (in <sup>2</sup> )	I <sub>x</sub> (in <sup>4</sup> )	R <sub>x</sub> (in)	I <sub>y</sub> (in <sup>4</sup> )	R <sub>y</sub> (in)	I <sub>x</sub> <sup>2</sup> (in <sup>4</sup> )	S <sub>x</sub> (in <sup>2</sup> )	Ma (ft-lb)
087F125-18	0.0188	0.070	0.009	0.356	0.035	0.710	0.0086	0.0160	26.41
087F125-30	0.0312	0.115	0.014	0.353	0.058	0.710	0.0143	0.0307	50.47
087F125-33	0.0346	0.127	0.016	0.351	0.064	0.710	0.0157	0.0337	55.43
087F125-43	0.0451	0.162	0.020	0.348	0.082	0.711	0.0196	0.0420	69.17
087F125-54	0.0566	0.200	0.023	0.334	0.075	0.609	0.0229	0.0560	80.79
150F125-18	0.0188	0.094	0.031	0.575	0.047	0.705	0.0299	0.0344	56.59
150F125-27	0.0283	0.140	0.046	0.572	0.070	0.705	0.0459	0.0569	93.74
150F125-30	0.0312	0.154	0.050	0.571	0.077	0.705	0.0503	0.0639	105.25
150F125-33	0.0346	0.171	0.055	0.570	0.085	0.705	0.0554	0.0704	115.92
150F125-43	0.0451	0.219	0.070	0.565	0.109	0.705	0.0699	0.0888	146.25

<sup>1</sup> Minimum base metal thickness is 95% of design thickness.

<sup>2</sup> Moment of inertia given is for deflection calculations.

<sup>3</sup> Effective properties are given as the minimum value for either positive or negative bending.

### Furring Channel Allowable Ceiling Spans L/240

Section	Thickness (mil)	F <sub>y</sub> ksi	Spans	4 psf			6 psf			13 psf		
				Channel Spacing (in) o.c.			Channel Spacing (in) o.c.			Channel Spacing (in) o.c.		
				12	16	24	12	16	24	12	16	24
087F125	18	33	Single	4' 6"	4' 1"	3' 7"	4' 0"	3' 7"	3' 2"	3' 1"	2' 9"	2' 5"
			Multiple	5' 7"	5' 1"	4' 5"	4' 11"	4' 5"	3' 11"	3' 9"	3' 5"	2' 10"
	30	33	Single	5' 5"	4' 11"	4' 3"	4' 8"	4' 3"	3' 9"	3' 8"	3' 4"	2' 11"
			Multiple	6' 8"	6' 1"	5' 3"	5' 10"	5' 3"	4' 7"	4' 6"	4' 1"	3' 7"
	43	33	Single	6' 0"	5' 5"	4' 9"	5' 3"	4' 9"	4' 2"	4' 0"	3' 8"	3' 2"
			Multiple	7' 5"	6' 9"	5' 10"	6' 6"	5' 10"	5' 2"	5' 0"	4' 6"	4' 0"
150F125	18	33	Single	6' 11"	6' 3"	5' 6"	6' 0"	5' 6"	4' 9"	4' 8"	4' 3"	3' 8"
			Multiple	8' 6"	7' 9"	6' 9"	7' 5"	6' 9"	5' 11"	5' 8"	4' 9"	3' 8"
	30	33	Single	8' 2"	7' 5"	6' 6"	7' 2"	6' 6"	5' 8"	5' 6"	5' 0"	4' 5"
			Multiple	10' 2"	9' 2"	8' 0"	8' 10"	8' 0"	7' 0"	6' 10"	6' 3"	5' 5"
	43	33	Single	9' 2"	8' 4"	7' 3"	8' 0"	7' 3"	6' 4"	6' 2"	5' 7"	4' 11"
			Multiple	11' 4"	10' 3"	9' 0"	9' 11"	9' 0"	7' 10"	7' 8"	6' 11"	6' 1"

### Furring Channel Allowable Ceiling Spans L/360

Section	Thickness (mil)	F <sub>y</sub> (ksi)	Spans	4 psf			6 psf			13 psf		
				Channel Spacing (in) o.c.			Channel Spacing (in) o.c.			Channel Spacing (in) o.c.		
				12	16	24	12	16	24	12	16	24
087F125	18	33	Single	5' 2"	4' 9"	4' 1"	4' 6"	4' 1"	3' 7"	3' 6"	3' 2"	2' 9"
			Multiple	6' 5"	5' 10"	5' 1"	5' 7"	5' 1"	4' 2"	4' 0"	3' 6"	2' 10"
	30	33	Single	6' 2"	5' 7"	4' 11"	5' 5"	4' 11"	4' 3"	4' 2"	3' 9"	3' 4"
			Multiple	7' 7"	6' 11"	6' 1"	6' 8"	6' 1"	5' 3"	5' 2"	4' 8"	3' 11"
	43	33	Single	6' 10"	6' 3"	5' 5"	6' 0"	5' 5"	4' 9"	4' 7"	4' 2"	3' 8"
			Multiple	8' 6"	7' 8"	6' 9"	7' 5"	6' 9"	5' 10"	5' 9"	5' 2"	4' 6"
150F125	18	33	Single	7' 11"	7' 2"	6' 3"	6' 11"	6' 3"	5' 6"	5' 4"	4' 10"	4' 2"
			Multiple	9' 9"	8' 10"	7' 6"	8' 6"	7' 6"	6' 0"	5' 8"	4' 9"	3' 8"
	30	33	Single	9' 5"	8' 6"	7' 5"	8' 2"	7' 5"	6' 6"	6' 4"	5' 9"	5' 0"
			Multiple	11' 7"	10' 6"	9' 2"	10' 2"	9' 2"	8' 0"	7' 10"	7' 0"	5' 8"
	43	33	Single	10' 6"	9' 6"	8' 4"	9' 2"	8' 4"	7' 3"	7' 1"	6' 5"	5' 7"
			Multiple	13' 0"	11' 9"	10' 3"	11' 4"	10' 3"	9' 0"	8' 9"	8' 0"	6' 8"

Notes:

- Single spans taken as the minimum span based on moment, shear, web crippling or deflection.
- Multiple spans indicate two or more equal, continuous spans with span length measured support to support.
- Multiple spans taken as the minimum span based on moment, shear, web crippling, deflection combined bending and shear or combined and web crippling.
- Web crippling values based on 1" bearing at end and interior supports.

## U-Channel

U-Channel is used in many common bridging and bracing applications. U-channel is available in 54 mil (16ga.) steel with 1/2" legs. Standard widths are 3/4", 1-1/2", 2" and 2-1/2".

### Designation

Industry standard nomenclature is used to identify MBA's products. The Steel Framing Industry Association has established standard designation codes for U-Channel. In each case, the identification starts with the measurement of the width of the member, followed by a letter (U = Channel Sections) followed by the flange dimension. A hyphen is used to separate all of this from the thickness of the metal.

#### Member Depth:

(Example: 2" = 200 x 1/100 inches)

All member depths are taken in 1/100 inches. For all "T" sections member depth is the inside to inside dimension.

#### Flange Width:

(Example: 1/2" = 0.50" = 050 x 1/100 inches)

All flange widths are taken in 1/100 inches.

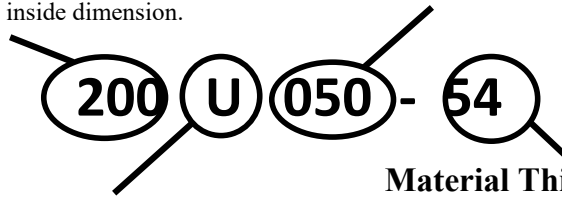

#### Style:

(Example: Channel Section = U)

The alpha character utilized by the designation system is:

U = Channel Sections

#### Material Thickness:

(Example: 0.054 in." = 54 mils; 1 mil = 1/1000 in.)

Material thickness is the minimum base metal thickness in mils.

Minimum base metal thickness represents 95% of the design thickness.

### Steel Thickness

Mils	Gauge	Thickness (in)	
		Design	Minimum <sup>1</sup>
54	16	0.0566	0.0538

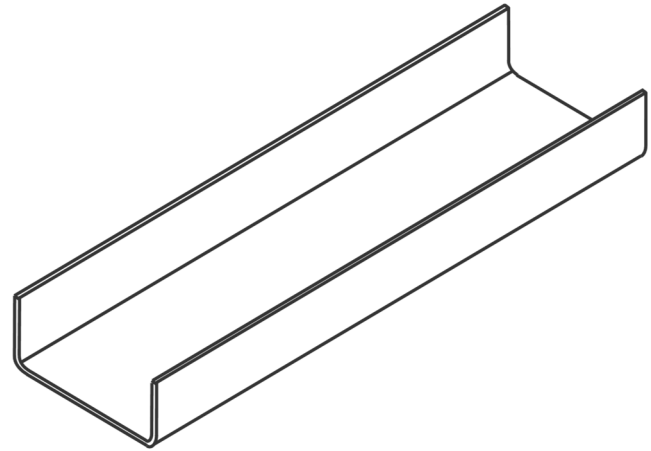

<sup>1</sup> Minimum Thickness represents 95% of the design thickness and is the minimum acceptable thickness delivered to the job site based on AISI S100-16/S2-20.

### General Notes

1. Calculated properties are based on AISI S100-16/S2-20, "North American Specification for Design of Cold-Formed Steel Structural Members."
2. Structural framing members have a protective coating conforming to ASTM C 955.
3. Reference ASTM specification A 1003/A 1003 M table 1 for the universe of allowable coatings for light gauge steel framing.
4. All delivered material must be kept dry, preferably by being stored inside a building under a roof. If it is necessary to store material outside, it must be stacked off the ground, properly supported on a level platform, and fully protected from the weather. Reference ASTM C 754 section 8 and ASTM C 1007 section 4.

### LEED Green Building Credits

MR Credit 2: Construction Waste Management – MBA steel framing is 100% recyclable.

MR Credit 4: Recycled Content – MBA steel framing is formed from no less than 25.5% post-consumer and 6.8% pre-consumer recycled content.

MR Credit 5: Regional Materials – MBA has manufacturing facilities in multiple states.

## Channel Properties

### U-Channel Section Properties

Section	Design Thickness (in)	Gross Properties					Effective Properties <sup>3</sup> (33ksi)			
		Area (in <sup>2</sup> )	I <sub>x</sub> (in <sup>4</sup> )	R <sub>x</sub> (in)	I <sub>y</sub> (in <sup>4</sup> )	R <sub>y</sub> (in)	I <sub>x</sub> <sup>2</sup> (in <sup>4</sup> )	S <sub>x</sub> (in <sup>3</sup> )	Ma (in-k)	Va (lb)
075U50-54	0.0566	0.087	0.007	0.288	0.002	0.155	0.007	0.019	0.45	315
150U50-54	0.0566	0.129	0.039	0.547	0.003	0.144	0.039	0.052	1.22	840
200U50-54	0.0566	0.157	0.079	0.709	0.003	0.136	0.079	0.079	1.87	1190
250U50-54	0.0566	0.186	0.139	0.866	0.003	0.128	0.139	0.111	2.64	1540

<sup>1</sup> Minimum base metal thickness is 95% of design thickness.

<sup>2</sup> Moment of inertia given is for deflection calculations.

<sup>3</sup> Effective properties are given as the minimum value for positive or negative bending.

### U-Channel Allowable Ceiling Spans L/360

Section	Spans	4 psf					6 psf					13 psf					15 psf				
		Channel Spacing (in) o.c.					Channel Spacing (in) o.c.					Channel Spacing (in) o.c.					Channel Spacing (in) o.c.				
		24	36	48	60	72	24	36	48	60	72	24	36	48	60	72	24	36	48	60	72
075U50-54	Single	3' 5"	3' 0"	2' 9"	2' 6"	2' 4"	3' 0"	2' 7"	2' 4"	2' 2"	2' 1"	2' 4"	2' 0"	1' 10"	1' 8"	1' 7"	2' 2"	1' 11"	1' 9"	1' 7"	1' 6"
	Multiple	4' 2"	3' 8"	3' 4"	3' 1"	2' 11"	3' 8"	3' 2"	2' 11"	2' 8"	2' 7"	2' 10"	2' 6"	2' 3"	2' 1"	1' 11"	2' 8"	2' 4"	2' 2"	2' 0"	1' 9"
150U50-54	Single	5' 6"	4' 10"	4' 5"	4' 1"	3' 10"	4' 10"	4' 3"	3' 10"	3' 7"	3' 5"	3' 9"	3' 4"	3' 0"	2' 9"	2' 7"	3' 7"	3' 2"	2' 10"	2' 7"	2' 5"
	Multiple	7' 1"	6' 2"	5' 8"	5' 3"	4' 11"	6' 2"	5' 5"	4' 11"	4' 7"	4' 4"	4' 10"	4' 2"	3' 9"	3' 4"	3' 0"	4' 7"	4' 0"	3' 6"	3' 1"	2' 9"
200U50-54	Single	5' 10"	5' 1"	4' 8"	4' 4"	4' 1"	5' 1"	4' 6"	4' 1"	3' 10"	3' 7"	4' 0"	3' 6"	3' 2"	3' 0"	2' 10"	3' 10"	3' 4"	3' 1"	2' 10"	2' 8"
	Multiple	7' 5"	6' 6"	5' 11"	5' 6"	5' 2"	6' 6"	5' 8"	5' 2"	4' 10"	4' 7"	5' 1"	4' 5"	4' 0"	3' 9"	3' 6"	4' 10"	4' 3"	3' 10"	3' 7"	3' 2"
250U50-54	Single	6' 1"	5' 4"	4' 10"	4' 6"	4' 3"	5' 4"	4' 8"	4' 3"	4' 0"	3' 9"	4' 2"	3' 8"	3' 4"	3' 1"	2' 11"	4' 0"	3' 6"	3' 2"	3' 0"	2' 10"
	Multiple	7' 9"	6' 9"	6' 2"	5' 9"	5' 5"	6' 9"	5' 11"	5' 5"	5' 0"	4' 9"	5' 3"	4' 7"	4' 3"	3' 11"	3' 9"	5' 0"	4' 5"	4' 0"	3' 9"	3' 7"

### U-Channel Allowable Ceiling Spans L/240

Section	Spans	4 psf					6 psf					13 psf					15 psf				
		Channel Spacing (in) o.c.					Channel Spacing (in) o.c.					Channel Spacing (in) o.c.					Channel Spacing (in) o.c.				
		24	36	48	60	72	24	36	48	60	72	24	36	48	60	72	24	36	48	60	72
075U50-54	Single	3' 11"	3' 5"	3' 1"	2' 11"	2' 9"	3' 5"	3' 0"	2' 9"	2' 6"	2' 4"	2' 8"	2' 4"	2' 1"	1' 11"	1' 9"	2' 6"	2' 2"	2' 0"	1' 10"	1' 8"
	Multiple	4' 10"	4' 2"	3' 10"	3' 7"	3' 4"	4' 2"	3' 8"	3' 4"	3' 1"	2' 10"	3' 3"	2' 9"	2' 4"	2' 1"	1' 11"	3' 1"	2' 7"	2' 2"	2' 0"	1' 9"
150U50-54	Single	5' 6"	4' 10"	4' 5"	4' 1"	3' 10"	4' 10"	4' 3"	3' 10"	3' 7"	3' 5"	3' 9"	3' 4"	3' 0"	2' 9"	2' 7"	3' 7"	3' 2"	2' 10"	2' 7"	2' 5"
	Multiple	7' 1"	6' 2"	5' 8"	5' 3"	4' 11"	6' 2"	5' 5"	4' 11"	4' 7"	4' 4"	4' 10"	4' 2"	3' 9"	3' 4"	3' 0"	4' 7"	4' 0"	3' 6"	3' 1"	2' 9"
200U50-54	Single	5' 10"	5' 1"	4' 8"	4' 4"	4' 1"	5' 1"	4' 6"	4' 1"	3' 10"	3' 7"	4' 0"	3' 6"	3' 2"	3' 0"	2' 10"	3' 10"	3' 4"	3' 1"	2' 10"	2' 8"
	Multiple	7' 5"	6' 6"	5' 11"	5' 6"	5' 2"	6' 6"	5' 8"	5' 2"	4' 10"	4' 7"	5' 1"	4' 5"	4' 0"	3' 9"	3' 6"	4' 10"	4' 3"	3' 10"	3' 7"	3' 2"
250U50-54	Single	6' 1"	5' 4"	4' 10"	4' 6"	4' 3"	5' 4"	4' 8"	4' 3"	4' 0"	3' 9"	4' 2"	3' 8"	3' 4"	3' 1"	2' 11"	4' 0"	3' 6"	3' 2"	3' 0"	2' 10"
	Multiple	7' 9"	6' 9"	6' 2"	5' 9"	5' 5"	6' 9"	5' 11"	5' 5"	5' 0"	4' 9"	5' 3"	4' 7"	4' 3"	3' 11"	3' 9"	5' 0"	4' 5"	4' 0"	3' 9"	3' 7"

### U-Channel Allowable Ceiling Spans L/120

Section	Spans	4 psf					6 psf					13 psf					15 psf				
		Channel Spacing (in) o.c.					Channel Spacing (in) o.c.					Channel Spacing (in) o.c.					Channel Spacing (in) o.c.				
		24	36	48	60	72	24	36	48	60	72	24	36	48	60	72	24	36	48	60	72
075U50-54	Single	4' 10"	4' 1"	3' 7"	3' 3"	3' 0"	4' 1"	3' 5"	3' 0"	2' 9"	2' 6"	2' 11"	2' 5"	2' 2"	1' 11"	1' 9"	2' 9"	2' 4"	2' 0"	1' 10"	1' 8"
	Multiple	5' 5"	4' 6"	4' 2"	3' 10"	3' 5"	4' 6"	3' 11"	3' 5"	3' 2"	2' 11"	3' 5"	2' 9"	2' 4"	2' 1"	1' 11"	3' 1"	2' 7"	2' 2"	2' 0"	1' 9"
150U50-54	Single	5' 6"	4' 10"	4' 5"	4' 1"	3' 10"	4' 10"	4' 3"	3' 10"	3' 7"	3' 5"	3' 9"	3' 4"	3' 0"	2' 9"	2' 7"	3' 7"	3' 2"	2' 10"	2' 7"	2' 5"
	Multiple	7' 1"	6' 2"	5' 8"	5' 3"	4' 11"	6' 2"	5' 5"	4' 11"	4' 7"	4' 4"	4' 10"	4' 2"	3' 9"	3' 4"	3' 0"	4' 7"	4' 0"	3' 6"	3' 1"	2' 9"
200U50-54	Single	5' 10"	5' 1"	4' 8"	4' 4"	4' 1"	5' 1"	4' 6"	4' 1"	3' 10"	3' 7"	4' 0"	3' 6"	3' 2"	3' 0"	2' 10"	3' 10"	3' 4"	3' 1"	2' 10"	2' 8"
	Multiple	7' 5"	6' 6"	5' 11"	5' 6"	5' 2"	6' 6"	5' 8"	5' 2"	4' 10"	4' 7"	5' 1"	4' 5"	4' 0"	3' 9"	3' 6"	4' 10"	4' 3"	3' 10"	3' 7"	3' 2"
250U50-54	Single	6' 1"	5' 4"	4' 10"	4' 6"	4' 3"	5' 4"	4' 8"	4' 3"	4' 0"	3' 9"	4' 2"	3' 8"	3' 4"	3' 1"	2' 11"	4' 0"	3' 6"	3' 2"	3' 0"	2' 10"
	Multiple	7' 9"	6' 9"	6' 2"	5' 9"	5' 5"	6' 9"	5' 11"	5' 5"	5' 0"	4' 9"	5' 3"	4' 7"	4' 3"	3' 11"	3' 9"	5' 0"	4' 5"	4' 0"	3' 9"	3' 7"

## Z-Furring

Z-Furring is used to provide support for insulation while allowing for drywall attachment at masonry or concrete walls. Z-furring is available in 18, 30, and 43 mil thicknesses (25-18ga.) and 1", 1-1/2", 2" and 2-1/2" depths. *Additional gauges are available upon request.*

Size	Thickness (mils)	Gauge	Length
1"	18	25	8'6", 10', 12' or Custom Lengths
	30	20	
	43	18	
1-1/2"	18	25	
	30	20	
	43	18	
2"	18	25	
	30	20	
	43	18	
2-1/2"	18	25	
	30	20	
	43	18	

Custom sizes available per customer request

### Steel Thickness

Mils	Gauge	Thickness (in)	
		Design	Minimum <sup>1</sup>
18	25	0.0188	0.0179
30	20	0.0312	0.0296
43	18	0.0451	0.0428

<sup>1</sup> Minimum Thickness represents 95% of the design thickness and is the minimum acceptable thickness delivered to the job site based on AISI S100-16/S2-20.

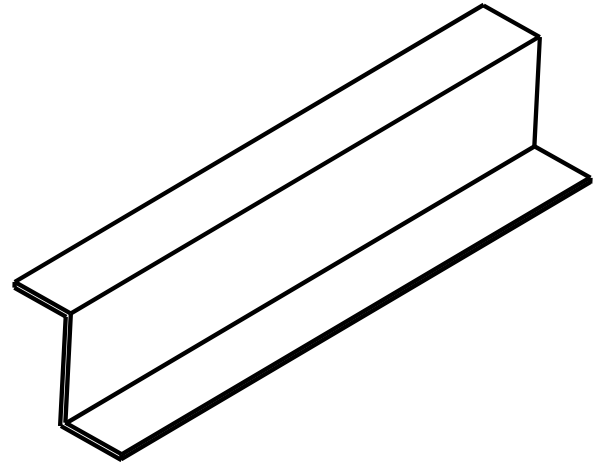

## General Notes

- Structural framing members have a protective coating conforming to ASTM C 955.
- Drywall framing members have a protective coating conforming to ASTM spec A 653/A 653M, G-40 min, or equivalent corrosion resistance.
- Reference ASTM specification A 1003/A 1003 M table 1 for the universe of allowable coatings for light gauge steel framing.
- All delivered material must be kept dry, preferably by being stored inside a building under a roof. If it is necessary to store material outside, it must be stacked off the ground, properly supported on a level platform, and fully protected from the weather. Reference ASTM C 754 section 8 and ASTM C 1007 section 4.
- Drywall framing [nonstructural 25 gauge and 20 gauge] is not permitted in load bearing (i.e. axial load greater than 200 lbs.) or exterior applications (i.e. transverse load greater than 10 PSF). Reference ASTM C 645 section 3.2.2.

## LEED Green Building Credits

MR Credit 2: Construction Waste Management – MBA steel framing is 100% recyclable.

MR Credit 4: Recycled Content – MBA steel framing is formed from no less than 25.5% post-consumer and 6.8% pre-consumer recycled content.

MR Credit 5: Regional Materials – MBA has manufacturing facilities in multiple states.

## Angle

Angle can be used in a variety of applications. Angle is available in a full range of gauges, leg lengths, and bend angles.

Leg Length	Thickness (mils)	Gauge	Length
7/8" x 1-3/8"	18	25	10' or custom lengths
	30	20	
1-1/2" x 1-1/2"	18	25	
	30	20	
	43	18	
2" x 2"	54	16	
	18	25	
	30	20	
	43	18	
	54	16	
3" x 3"	68	14	
	18	25	
	30	20	
	43	18	
	54	16	
	68	14	

Custom sizes available per customer request

### Steel Thickness

Mils	Gauge	Thickness (in)	
		Design	Minimum <sup>1</sup>
18	25	0.0188	0.0179
30	20	0.0312	0.0296
43	18	0.0451	0.0428
54	16	0.0566	0.0538
68	14	0.0713	0.0677

<sup>1</sup> Minimum Thickness represents 95% of the design thickness and is the minimum acceptable thickness delivered to the job site based on AISI S100-16/S2-20.

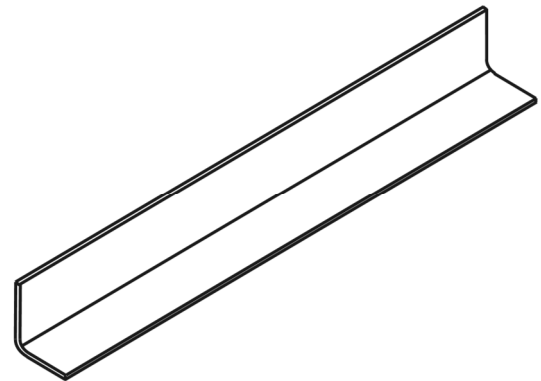

## General Notes

- All delivered material must be kept dry, preferably by being stored inside a building under a roof. If it is necessary to store material outside, it must be stacked off the ground, properly supported on a level platform, and fully protected from the weather. Reference ASTM C 754 section 8 and ASTM C 1007 section 4.
- Drywall framing [nonstructural 25 gauge and 20 gauge] is not permitted in load bearing (i.e. axial load greater than 200 lbs.) or exterior applications (i.e. transverse load greater than 10 PSF). Reference ASTM C 645 section 3.2.2.

## LEED Green Building Credits

MR Credit 2: Construction Waste Management – MBA steel framing is 100% recyclable.

MR Credit 4: Recycled Content – MBA steel framing is formed from no less than 25.5% post-consumer and 6.8% pre-consumer recycled content.

MR Credit 5: Regional Materials – MBA has manufacturing facilities in multiple states.

## Flat Strap

Flat strap can be used in a variety of applications. Flat strap is available in a full range of gauges, lengths, and yields.

Strap Width (in)	Yield Strength (ksi)	Tensile Strength (lbs)							
		Gauge							
		18	27	30	33	43	54	68	97
1	33	371	559	617	684	891	1118	1409	2010
2	33	743	1118	1233	1367	1782	2237	2818	4019
3	33	1114	1678	1850	2051	2674	3355	4227	6029
4	33	1486	2237	2466	2735	3565	4474	5636	8039
5	33	1857	2796	3083	3419	4456	5592	7045	10048
6	33	2229	3355	3699	4102	5347	6711	8454	12058
7	33	2600	3915	4316	4786	6238	7829	9862	14067
8	33	2972	4474	4932	5470	7130	8948	11271	16077
9	33	3343	5033	5549	6153	8021	10066	12680	18087
10	33	3715	5592	6165	6837	8912	11184	14089	20096
11	33	4086	6151	6782	7521	9803	12303	15498	22106
12	33	4458	6711	7398	8205	10694	13421	16907	24116

### Steel Thickness

Mils	Gauge	Design	Thickness (in)	
			Minimum <sup>1</sup>	Color Code
15	25 EQ	0.0158	0.0150	Dark Gray
18	25	0.0188	0.0179	No Color
18	20 EQ	0.0190	0.0181	Brown
30	DW20	0.0312	0.0296	Pink
33	20	0.0346	0.0329	White
43	18	0.0451	0.0428	Yellow
54	16	0.0566	0.0538	Green
68	14	0.0713	0.0677	Orange
97	12	0.1017	0.0966	Red
118	10	0.1242	0.1180	Blue

<sup>1</sup> Minimum Thickness represents 95% of the design thickness and is the minimum acceptable thickness delivered to the job site based on AISI S100-16/S2-20.

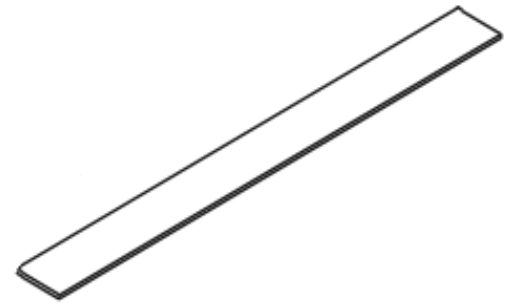

## General Notes

- All delivered material must be kept dry, preferably by being stored inside a building under a roof. If it is necessary to store material outside, it must be stacked off the ground, properly supported on a level platform, and fully protected from the weather. Reference ASTM C 754 section 8 and ASTM C 1007 section 4.
- Drywall framing [nonstructural 25 gauge, 22 gauge and 20 gauge] is not permitted in load bearing (i.e. axial load greater than 200 lbs.) or exterior applications (i.e. transverse load greater than 10 PSF). Reference ASTM C 645 section 3.2.2.

## LEED Green Building Credits

MR Credit 2: Construction Waste Management – MBA steel framing is 100% recyclable.

MR Credit 4: Recycled Content – MBA steel framing is formed from no less than 25.5% post-consumer and 6.8% pre-consumer recycled content.

MR Credit 5: Regional Materials – MBA has manufacturing facilities in multiple states.

## Resilient Channel-1 18 MIL

Resilient channel may be used to reduce sound transmission from gypsum to steel framing member assemblies. Resilient Channel is available in 1-1/4" screw flanges. Resilient channel is available in 18 and 22 mil thicknesses. Standard channel lengths are 12 foot long. Custom resilient channel lengths are available on request.

### Steel Thickness

Mils	Gauge	Thickness (in)	
		Design	Minimum <sup>1</sup>
18	25	0.0188	0.0179

<sup>1</sup> Minimum Thickness represents 95% of the design thickness and is the minimum acceptable thickness delivered to the job site based on AISI S100-16/S2-20.

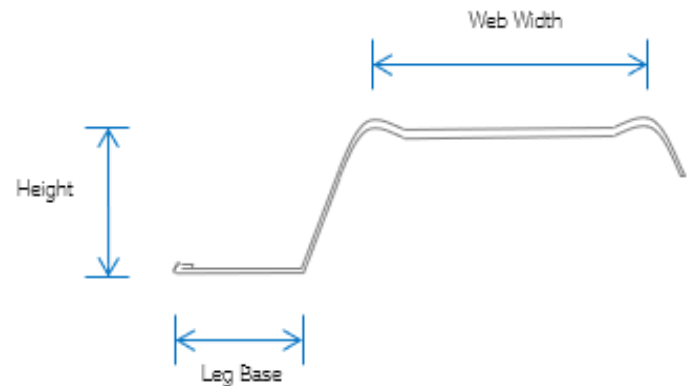

### Dimensions

Mil	18 mil
Height	0.50 in
Leg Base	0.50 in
Web Width	1.25 in
Yield Strength	33 ksi
Weight per Foot	0.158 lb/ft
Coating	G40EQ, G40, G60

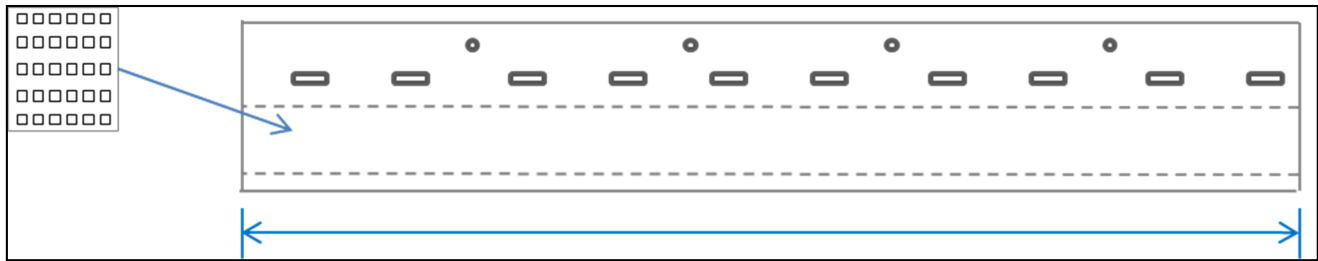

### General Notes

- Physical properties have been calculated in conformance with the AISI S100-16/S2-20.
- Drywall framing members have a protective coating conforming to ASTM spec A 653/A 653M, G-40 min, or equivalent corrosion resistance.
- Reference ASTM specification A 1003/A 1003 M table 1 for the universe of allowable coatings for light gauge steel framing.
- All delivered material must be kept dry, preferably by being stored inside a building under a roof. If it is necessary to store material outside, it must be stacked off the ground, properly supported on a level platform, and fully protected from the weather. Reference ASTM C 754 section 8 and ASTM C 1007 section 4.
- Drywall framing [nonstructural 25 gauge and 20 gauge] is not permitted in load bearing (i.e. axial load greater than 200 lbs.) or exterior applications (i.e. transverse load greater than 10 PSF). Reference ASTM C 645 section 3.2.2.

### LEED Green Building Credits

MR Credit 2: Construction Waste Management – MBA steel framing is 100% recyclable.

MR Credit 4: Recycled Content – MBA steel framing is formed from no less than 25.5% post-consumer and 6.8% pre-consumer recycled content.

MR Credit 5: Regional Materials – MBA has manufacturing facilities in multiple states.

## Resilient Channel-1 22 MIL

Resilient channel may be used to reduce sound transmission from gypsum to steel framing member assemblies. Resilient Channel is available in 1-1/4" screw flanges. Resilient channel is available in 18 and 22 mil thicknesses. Standard channel lengths are 12 foot long. Custom resilient channel lengths are available on request.

### Steel Thickness

Mils	Gauge	Thickness (in)	
		Design	Minimum <sup>1</sup>
22	20	0.0232	0.0220

<sup>1</sup> Minimum Thickness represents 95% of the design thickness and is the minimum acceptable thickness delivered to the job site based on AISI S100-16/S2-20.

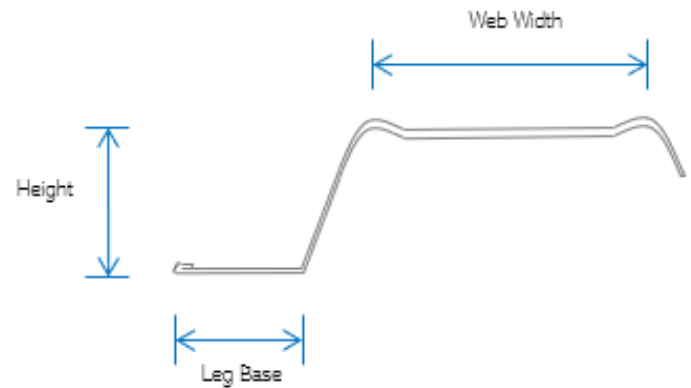

### Dimensions

Mil	22 mil
Height	0.50 in
Leg Base Length	0.50 in
Web Width	1.25 in
Yield Strength	33 ksi
Weight per Foot	0.243 lb/ft
Coating	G40EQ, G40, G60

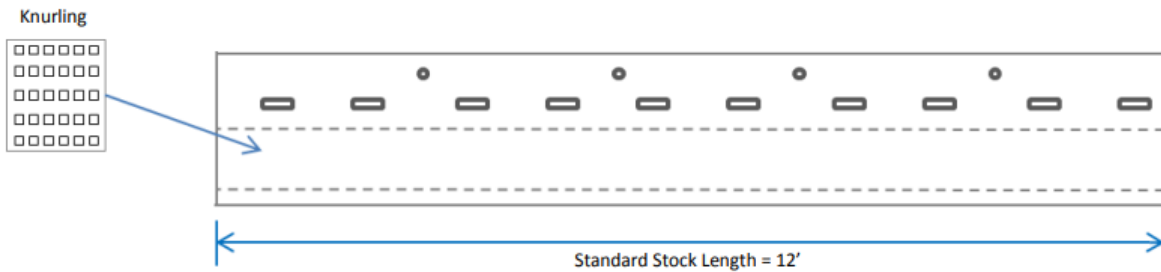

### General Notes

1. Physical properties have been calculated in conformance with the AISI S100-16/S2-20.
2. Drywall framing members have a protective coating conforming to ASTM spec A 653/A 653M, G-40 min, or equivalent corrosion resistance.
3. Reference ASTM specification A 1003/A 1003 M table 1 for the universe of allowable coatings for light gauge steel framing.
4. All delivered material must be kept dry, preferably by being stored inside a building under a roof. If it is necessary to store material outside, it must be stacked off the ground, properly supported on a level platform, and fully protected from the weather. Reference ASTM C 754 section 8 and ASTM C 1007 section 4.
5. Drywall framing [nonstructural 25 gauge and 20 gauge] is not permitted in load bearing (i.e. axial load greater than 200 lbs.) or exterior applications (i.e. transverse load greater than 10 PSF). Reference ASTM C 645 section 3.2.2.

### LEED Green Building Credits

MR Credit 2: Construction Waste Management – MBA steel framing is 100% recyclable.

MR Credit 4: Recycled Content – MBA steel framing is formed from no less than 25.5% post-consumer and 6.8% pre-consumer recycled content.

MR Credit 5: Regional Materials – MBA has manufacturing facilities in multiple states.

## Resilient Channel-2 18 MIL

Resilient channel may be used to reduce sound transmission from gypsum to steel framing member assemblies. Resilient Channel is available in 1-1/4" screw flanges. Resilient channel is available in 18 and 22 mil thicknesses. Standard channel lengths are 12 foot long. Custom resilient channel lengths are available on request.

### Steel Thickness

Mils	Gauge	Thickness (in)	
		Design	Minimum <sup>1</sup>
18	25	0.0188	0.0179

<sup>1</sup> Minimum Thickness represents 95% of the design thickness and is the minimum acceptable thickness delivered to the job site based on AISI S100-16/S2-20.

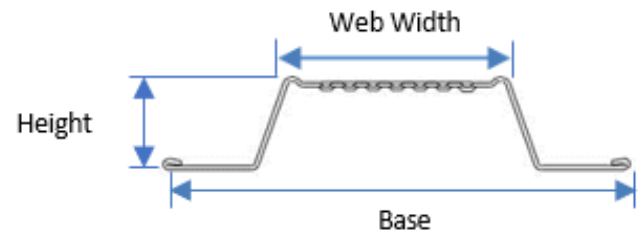

### Dimensions

Mil	18 mil
Height	0.50 in
Base Length	2.50
Web Width	1.25 in
Yield Strength	33 ksi
Weight Per Foot	0.213lb/ft
Coating	G40EQ, G40, G60

Knurling

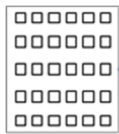

### General Notes

- Physical properties have been calculated in conformance with the AISI S100-16/S2-20.
- Drywall framing members have a protective coating conforming to ASTM spec A 653/A 653M, G-40 min, or equivalent corrosion resistance.
- Reference ASTM specification A 1003/A 1003 M table 1 for the universe of allowable coatings for light gauge steel framing.
- All delivered material must be kept dry, preferably by being stored inside a building under a roof. If it is necessary to store material outside, it must be stacked off the ground, properly supported on a level platform, and fully protected from the weather. Reference ASTM C 754 section 8 and ASTM C 1007 section 4.
- Drywall framing [nonstructural 25 gauge and 20 gauge] is not permitted in load bearing (i.e. axial load greater than 200 lbs.) or exterior applications (i.e. transverse load greater than 10 PSF). Reference ASTM C 645 section 3.2.2.

### LEED Green Building Credits

MR Credit 2: Construction Waste Management – MBA steel framing is 100% recyclable.

MR Credit 4: Recycled Content – MBA steel framing is formed from no less than 25.5% post-consumer and 6.8% pre-consumer recycled content.

MR Credit 5: Regional Materials – MBA has manufacturing facilities in multiple states.

For more information, please call (888)-248-8076 or go to [www.mbastuds.com](http://www.mbastuds.com)

The information contained herein supersedes any and all previous information, effective 07/16/2025

## Resilient Channel-2 22 MIL

Resilient channel may be used to reduce sound transmission from gypsum to steel framing member assemblies. Resilient Channel is available in 1-1/4" screw flanges. Resilient channel is available in 18 and 22 mil thicknesses. Standard channel lengths are 12 foot long. Custom resilient channel lengths are available on request.

### Steel Thickness

Mils	Gauge	Thickness (in)	
		Design	Minimum <sup>1</sup>
22	20	0.0232	0.0220

<sup>1</sup> Minimum Thickness represents 95% of the design thickness and is the minimum acceptable thickness delivered to the job site based on AISI S100-16/S2-20.

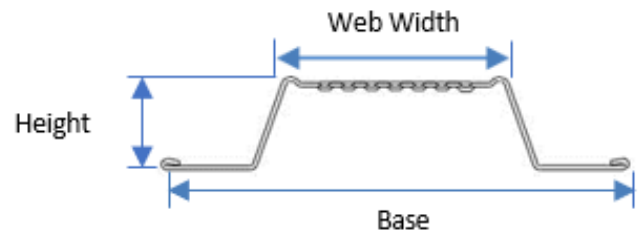

### Dimensions

Mil	22 mil
Height	0.50 in
Base Length	2.50 in
Web Width	1.25 in
Yield Strength	33 ksi
Weight Per Foot	0.263 lb/ft
Coating	G40EQ, G40, G60

Knurling

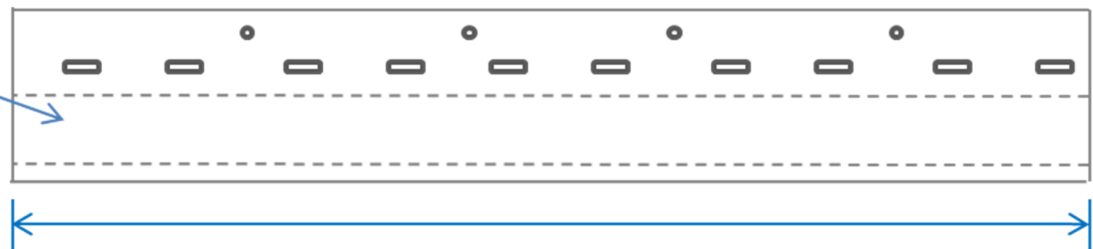
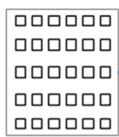

## General Notes

- Physical properties have been calculated in conformance with the AISI S100-16/S2-20.
- Drywall framing members have a protective coating conforming to ASTM spec A 653/A 653M, G-40 min, or equivalent corrosion resistance.
- Reference ASTM specification A 1003/A 1003 M table 1 for the universe of allowable coatings for light gauge steel framing.
- All delivered material must be kept dry, preferably by being stored inside a building under a roof. If it is necessary to store material outside, it must be stacked off the ground, properly supported on a level platform, and fully protected from the weather. Reference ASTM C 754 section 8 and ASTM C 1007 section 4.
- Drywall framing [nonstructural 25 gauge and 20 gauge] is not permitted in load bearing (i.e. axial load greater than 200 lbs.) or exterior applications (i.e. transverse load greater than 10 PSF). Reference ASTM C 645 section 3.2.2.

## LEED Green Building Credits

MR Credit 2: Construction Waste Management – MBA steel framing is 100% recyclable.

MR Credit 4: Recycled Content – MBA steel framing is formed from no less than 25.5% post-consumer and 6.8% pre-consumer recycled content.

MR Credit 5: Regional Materials – MBA has manufacturing facilities in multiple states.

**For more information, please call (888)-248-8076 or go to [www.mbastuds.com](http://www.mbastuds.com)**

The information contained herein supersedes any and all previous information, effective 07/16/2025

## CRC Clip

CRC Clips help to assure minimal movement of steel framing members. The clip secures u channel directly to the web of the stud to add strength and stability to the assembly.

### Allowable Loads Table Notes

1. Attachment to bridging and studs using #10-16 screws through the four pre-punched holes.
2. Bridging member thickness assumed to be 16 gage minimum,  $F_y=50$  ksi.
3. Allowable M1 loads are based on bridging clip and bridging-to-clip connection strength only.
4. Strength of F1 and M1 connection to stud must be determined by design engineer.
5. Allowable loads have not been increased for wind or seismic.

Clip	Number of Screws	Allowable Loads	
		F1 (lbs)	M1 (lbs-in)
150CC325-54	4	156	444
150CC525-54	4	252	444

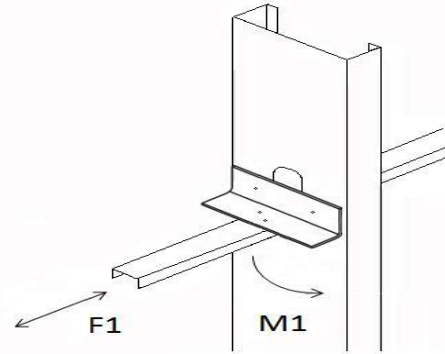

### Steel Thickness

Clip	Design Thickness <sup>1</sup> (in)	Gauge	Leg Length (in)	Total Length (in)	Weight (lbs)	Yield (ksi)	Coating
150CC325-54	0.0566	16	1.50	3.250	0.156	50	G90
150CC525-54	0.0566	16	1.50	5.250	0.252	50	G90

<sup>1</sup> Minimum Thickness represents 95% of the design thickness and is the minimum acceptable thickness delivered to the job site based on AISI S100-16/S2-20.

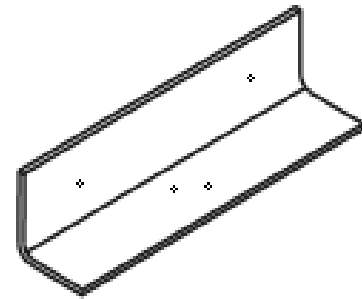

## General Notes

1. All delivered material must be kept dry, preferably by being stored inside a building under a roof. If it is necessary to store material outside, it must be stacked off the ground, properly supported on a level platform, and fully protected from the weather. Reference ASTM C 754 section 8 and ASTM C 1007 section 4.
2. Drywall framing [nonstructural 25 gauge, 22 gauge and 20 gauge] is not permitted in load bearing (i.e. axial load greater than 200 lbs.) or exterior applications (i.e. transverse load greater than 10 PSF). Reference ASTM C 645 section 3.2.2.

## LEED Green Building Credits

MR Credit 2: Construction Waste Management – MBA steel framing is 100% recyclable.

MR Credit 4: Recycled Content – MBA steel framing is formed from no less than 25.5% post-consumer and 6.8% pre-consumer recycled content.

MR Credit 5: Regional Materials – MBA has manufacturing facilities in multiple states.

## Web Stiffener

Web Stiffeners are used in applications to add strength to joist and header framing members. The stiffener length of the material depicts the web width that the stiffener will fit into to add additional support. Web stiffeners are common in 68 mil thickness (14ga.). Custom web stiffener lengths are available on request.

### Steel Thickness

Mils	Gauge	Thickness (in)	
		Design	Minimum <sup>1</sup>
68	14	0.0713	0.6770

### Dimensions

Web Width	4.00 in
Leg Length	1.25 in
Coating	CP60

<sup>1</sup> Minimum Thickness represents 95% of the design thickness and is the minimum acceptable thickness delivered to the job site based on AISI S100-16/S2-20.

Thickness (mils)	Gauge	Stiffener Length
68	14	3-3/8", 5-3/4", 7-3/4" 9-3/4", 11-3/4", 13-3/4" or custom
or custom	or custom	

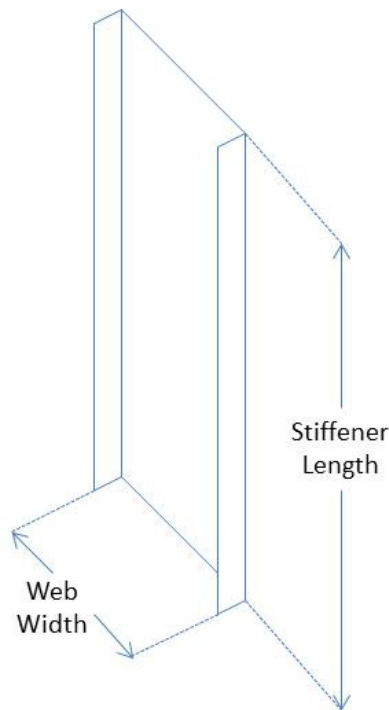

## General Notes

- Physical properties and load tables have been calculated in conformance with the AISI S100-16/S2-20.
- All structural framing members have a protective coating conforming to ASTM C 955.
- Reference ASTM specification A 1003/A 1003 M table 1 for the universe of allowable coatings for light gauge steel framing.
- Stud/joists are manufactured to custom lengths. Stud/joists are manufactured with punched webs unless otherwise specified at time of order.
- Track is produced in standard lengths of 10 feet unless a custom track length is indicated. Track is manufactured with unpunched webs.
- Structural framing members are marked with product information per the requirements of ASTM C 955 section 12.
- All delivered material must be kept dry, preferably by being stored inside a building under a roof. If it is necessary to store material outside, it must be stacked off the ground, properly supported on a level platform, and fully protected from the weather. Reference ASTM C 754 section 8 and ASTM C 1007 section 4.

## LEED Green Building Credits

MR Credit 2: Construction Waste Management – MBA steel framing is 100% recyclable.

MR Credit 4: Recycled Content – MBA steel framing is formed from no less than 25.5% post-consumer and 6.8% pre-consumer recycled content.

MR Credit 5: Regional Materials – MBA has manufacturing facilities at multiple locations.

## Slotted Track

Slotted Track is used in conditions that may contain vertical movement within the framing structure. The attachment location of the slotted track allows for a deflection amount of  $1 \frac{7}{10}$ " ( $\pm \frac{17}{20}$ ") of vertical travel. MBA's slotted track is available in 2-1/2" thru 10" web widths. Slotted Track is available in 18 thru 68 mil thicknesses (25-14ga.).

### Steel Thickness

Mils	Gauge	Thickness (in)	
		Design	Minimum <sup>1</sup>
18	25	0.0188	0.0179
30	20	0.0312	0.0296
33	20	0.0346	0.0329
43	18	0.0451	0.0428
54	16	0.0566	0.0538
68	14	0.0713	0.0677

<sup>1</sup> Minimum Thickness represents 95% of the design thickness and is the minimum acceptable thickness delivered to the job site based on AISI S100-16/S2-20.

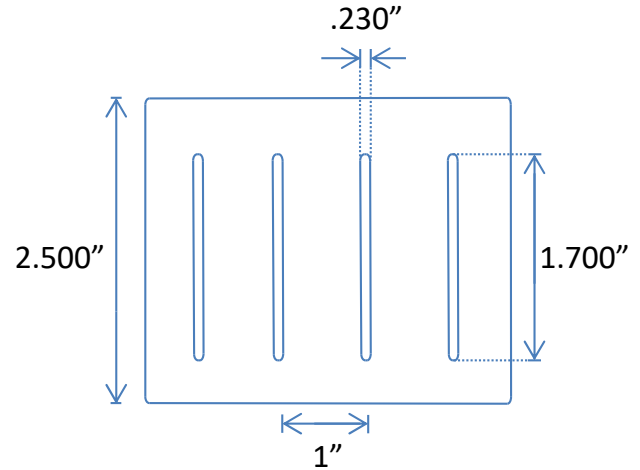

### Dimensions

Web Width	2-1/2", 3-5/8", 4", 6", 8", or 10"
Yield Strength	33 ksi for 25ga, 20ga, & 18ga 50 ksi for 16ga & 14ga
Coating	G40EQ (G40 or 60 Available for 30mil), CP60 for 33 mil (G90 Available)
Leg Length	2-1/2" or 3"
Slot Length	1-7/10"

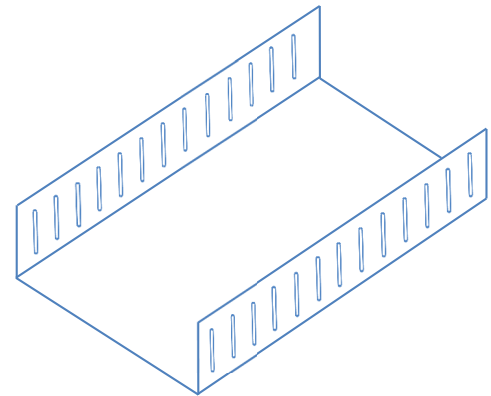

### General Notes

- Physical properties have been calculated in conformance with the AISI S100-16/S2-20.
- Drywall framing members have a protective coating conforming to ASTM spec A 653/A 653M, G-40 min, or equivalent corrosion resistance.
- All structural framing members have a protective coating conforming to ASTM C 955.
- Reference ASTM specification A 1003/A 1003 M table 1 for the universe of allowable coatings for light gauge steel framing.
- All delivered material must be kept dry, preferably by being stored inside a building under a roof. If it is necessary to store material outside, it must be stacked off the ground, properly supported on a level platform, and fully protected from the weather. Reference ASTM C 754 section 8 and ASTM C 1007 section 4.
- Drywall framing [nonstructural 25 gauge, 22 gauge and 20 gauge] is not permitted in load bearing (i.e. axial load greater than 200 lbs.) or exterior applications (i.e. transverse load greater than 10 PSF). Reference ASTM C 645 section 3.2.2.
- Track is produced in standard lengths of 10 feet unless a custom track length is indicated. Track is manufactured with unpunched webs.

### LEED Green Building Credits

MR Credit 2: Construction Waste Management – MBA steel framing is 100% recyclable.

MR Credit 4: Recycled Content – MBA steel framing is formed from no less than 25.5% post-consumer and 6.8% pre-consumer recycled content.

MR Credit 5: Regional Materials – MBA has manufacturing facilities in multiple states.

## Shaftwall

Shaftwall systems are used to aid in the construction of elevator shafts, mechanical shafts, stairwells, air return shafts and horizontal membranes. The system is designed to use with 1" gypsum board. MBA's shaftwall is available in 2-1/2", 4", or 6" sizes. Shaftwall is available in 18 and 33 mil thicknesses (25-20ga.).

### Steel Thickness

Mils	Gauge	Thickness (in)	
		Design	Minimum <sup>1</sup>
22	25	0.0188	0.0179
33	20	0.0346	0.0329
43	18	0.0451	0.0436

<sup>1</sup> Minimum Thickness represents 95% of the design thickness and is the minimum acceptable thickness delivered to the job site based on AISI S100-16/S2-20.

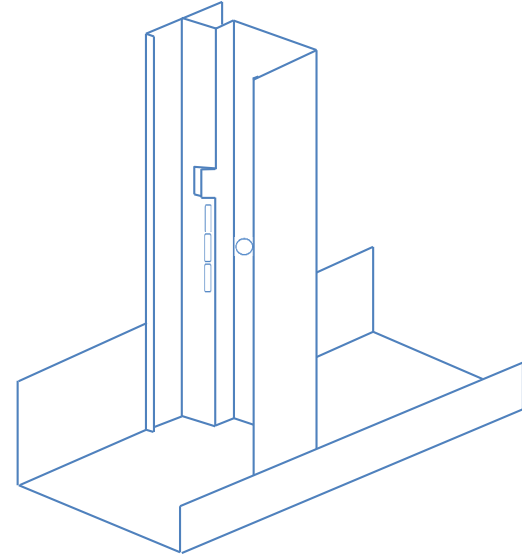

### Dimensions

Web Width	2-1/2", 4", or 6"
Yield Strength	33 ksi
Coating	G40EQ (G40/G60 available)
Tab Spacing	24"

### CT Stud

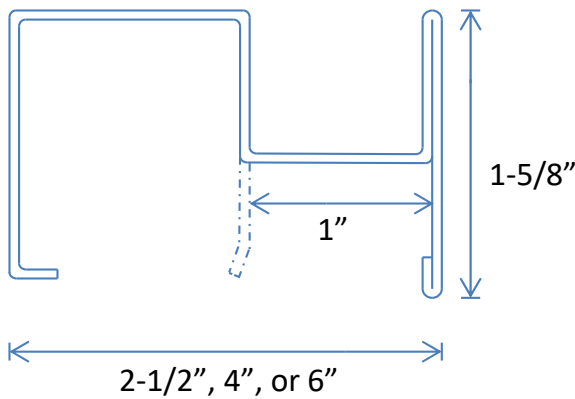

### Tab Track

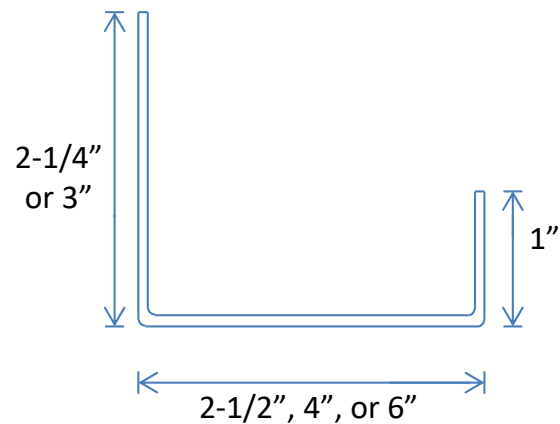

### General Notes

- Physical properties have been calculated in conformance with the AISI S100-16/S2-20.
- Drywall framing members have a protective coating conforming to ASTM spec A 653/A 653M, G-40 min, or equivalent corrosion resistance.
- Reference ASTM specification A 1003/A 1003 M table 1 for the universe of allowable coatings for light gauge steel framing.
- All delivered material must be kept dry, preferably by being stored inside a building under a roof. If it is necessary to store material outside, it must be stacked off the ground, properly supported on a level platform, and fully protected from the weather. Reference ASTM C 754 section 8 and ASTM C 1007 section 4.
- Drywall framing [nonstructural 25 gauge and 20 gauge] is not permitted in load bearing (i.e. axial load greater than 200 lbs.) or exterior applications (i.e. transverse load greater than 10 PSF). Reference ASTM C 645 section 3.2.2.

### LEED Green Building Credits

MR Credit 2: Construction Waste Management – MBA steel framing is 100% recyclable.

MR Credit 4: Recycled Content – MBA steel framing is formed from no less than 25.5% post-consumer and 6.8% pre-consumer recycled content.

MR Credit 5: Regional Materials – MBA has manufacturing facilities in multiple states.

## Shaftwall Limiting Wall Heights

Shaftwall systems are used to aid in the construction of elevator shafts, mechanical shafts, stairwells, air return shafts and horizontal membranes. The system is designed to use with 1" gypsum board. MBA's shaftwall is available in 2-1/2", 4", or 6" sizes. Shaftwall is available in 18 and 33 mil thicknesses (25-20ga.).

Section	Gauge	5psf				7.5psf				10psf				15psf		
		L/120	L/180	L/240	L/360	L/120	L/180	L/240	L/360	L/120	L/180	L/240	L/360	L/120	L/180	L/240
250CT-22	25	12' - 10"	11' - 3"	10' - 2"	8' - 11"	11' - 3"	9' - 10"	8' - 11"	7' - 9"	10' - 2"	8' - 11"	8' - 1"	7' - 1"	8' - 8"	7' - 9"	7' - 1"
250CT-33	20	14' - 7"	12' - 9"	11' - 7"	10' - 1"	12' - 9"	11' - 1"	10' - 1"	8' - 10"	11' - 7"	10' - 1"	9' - 2"	8' - 0"	10' - 1"	8' - 10"	8' - 0"
250CT-43	18	15' - 10"	13' - 10"	12' - 7"	10' - 11"	13' - 10"	12' - 1"	10' - 11"	9' - 7"	12' - 7"	10' - 11"	9' - 11"	8' - 8"	10' - 11"	9' - 7"	8' - 8"
400CT-22	25	18' - 5"	16' - 1"	14' - 7"	12' - 9"	16' - 1"	14' - 1"	12' - 9"	11' - 2"	12' - 8"	12' - 8"	11' - 7"	10' - 1"	8' - 5"	8' - 5"	8' - 5"
400CT-33	20	20' - 11"	18' - 3"	16' - 7"	14' - 6"	18' - 3"	16' - 0"	14' - 6"	12' - 8"	16' - 7"	14' - 6"	13' - 2"	11' - 6"	14' - 3"	12' - 8"	11' - 6"
400CT-43	18	22' - 9"	19' - 10"	18' - 0"	15' - 9"	19' - 10"	17' - 4"	15' - 9"	13' - 9"	18' - 0"	15' - 9"	14' - 4"	12' - 6"	15' - 9"	13' - 9"	12' - 6"
600CT-22	25	12' - 0"	12' - 0"	12' - 0"	12' - 0"	8' - 0"	8' - 0"	8' - 0"	8' - 0"	6' - 0"	6' - 0"	6' - 0"	6' - 0"	4' - 0"	4' - 0"	4' - 0"
600CT-33	20	28' - 10"	25' - 2"	22' - 11"	20' - 0"	25' - 2"	22' - 0"	20' - 0"	17' - 6"	22' - 11"	20' - 0"	18' - 2"	15' - 10"	16' - 11"	16' - 11"	15' - 10"
600CT-43	18	31' - 5"	27' - 5"	24' - 11"	21' - 9"	27' - 5"	23' - 11"	21' - 9"	19' - 0"	24' - 11"	21' - 9"	19' - 9"	17' - 3"	21' - 6"	19' - 0"	17' - 3"

<sup>1</sup> Minimum Thickness represents 95% of the design thickness and is the minimum acceptable thickness delivered to the job site based on AISI S100-16/S2-20.

## Area Separation

H-Stud and C-Runner systems are used to aid in the construction of party walls. Also known as area separation walls. They are designed to use with 1" gypsum board and are non-load-bearing. This system is easier to install compared to masonry walls and saves floor space as the system is only 3-1/2" thick.

Mils	Gauge	Thickness (in)	
		Design	Minimum <sup>1</sup>
18	25	0.0188	0.0179
30	20	0.0312	0.0296

<sup>1</sup> Minimum Thickness represents 95% of the design thickness and is the minimum acceptable thickness delivered to the job site based on AISI S100-16/S2-20. Standard coating is G40, also available in G60.

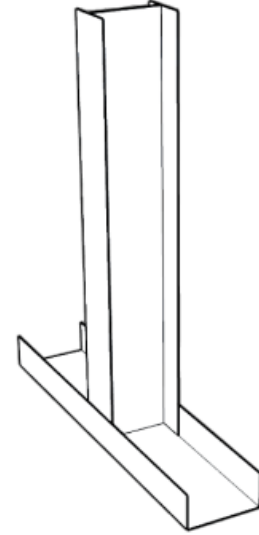

### Dimensions

Web Width	2-1/2", 4", or 6
Yield Strength	33 ksi
Coating	G40EQ (G40/G60 available)
Tab Spacing	24"

### H Stud

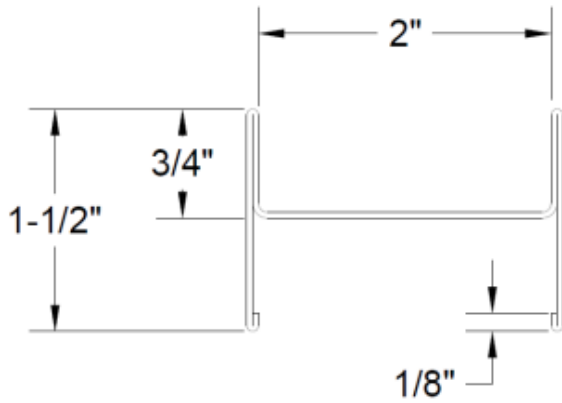

### C-Runner

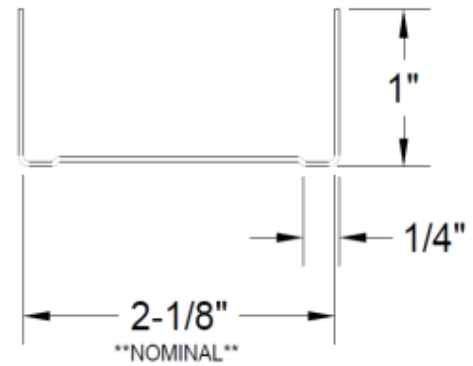

### General Notes

- Physical properties have been calculated in conformance with the AISI S100-16/S2-20.
- Drywall framing members have a protective coating conforming to ASTM spec A 653/A 653M, G-40 min, or equivalent corrosion resistance.
- Reference ASTM specification A 1003/A 1003 M table 1 for the universe of allowable coatings for light gauge steel framing.
- All delivered material must be kept dry, preferably by being stored inside a building under a roof. If it is necessary to store material outside, it must be stacked off the ground, properly supported on a level platform, and fully protected from the weather. Reference ASTM C 754 section 8 and ASTM C 1007 section 4.
- Drywall framing [nonstructural 25 gauge and 20 gauge] is not permitted in load bearing (i.e. axial load greater than 200 lbs.) or exterior applications (i.e. transverse load greater than 10 PSF). Reference ASTM C 645 section 3.2.2.

### LEED Green Building Credits

MR Credit 2: Construction Waste Management – MBA steel framing is 100% recyclable.

MR Credit 4: Recycled Content – MBA steel framing is formed from no less than 25.5% post-consumer and 6.8% pre-consumer recycled content.

MR Credit 5: Regional Materials – MBA has manufacturing facilities in multiple states.

