

ProSTUD[®] Drywall Framing System



MBA
METAL FRAMING

Section Properties

Section Properties Table Notes

1. Section properties were determined in accordance with AISI NASPEC 2001 w/ 2004 supplement.
2. Calculated effective moment of inertia (I_{xe}) is based on serviceability determination.
3. Effective properties and moment capacity did not incorporate stress increase as a result of cold work of forming.
4. Effective Properties are conservatively based upon the basic C-Section, improved values are possible by applying the AISI Direct Strength Method.
5. Allowable bending moment is based on a fully braced section about its major axis.

Non-Structural (PS) ProSTUD™ Section Properties

Section	Design Thickness (in)	Yield Strength	Gross Properties							Effective Properties				Torsional					Unbraced Length (in)
			Area (in ²)	Weight (lb/ft)	I _x (in ⁴)	S _x (in ³)	R _x (in)	I _y (in ⁴)	R _y (in)	A _e (in ²)	I _{xe} (in ⁴)	S _{xe} (in ³)	M _a (in-lbs)	J ^{x1000} (in ⁴)	C _w (in ⁶)	X _o (in)	R _o (in)	β	
162PS125-15	0.0158	70ksi	0.071	0.241	0.033	0.041	0.688	0.015	0.466	0.028	0.028	0.022	902	0.006	0.009	-1.088	1.369	0.368	20.9
250PS125-15	0.0158	70ksi	0.085	0.288	0.088	0.070	1.020	0.018	0.459	0.029	0.077	0.038	1582	0.007	0.023	-0.959	1.473	0.576	20.7
362PS125-15	0.0158	70ksi	0.102	0.348	0.206	0.114	1.420	0.020	0.442	0.029	0.159	0.051	2128	0.009	0.051	-0.837	1.706	0.760	20.5
400PS125-15	0.0158	70ksi	0.108	0.369	0.260	0.130	1.549	0.021	0.436	0.029	0.197	0.056	2364	0.009	0.064	-0.803	1.798	0.800	20.5
550PS125-15 ¹	0.0158	70ksi	0.132	0.449	0.553	0.201	2.047	0.022	0.411	0.029	0.410	0.084	3502	0.011	0.132	-0.695	2.201	0.900	20.1
600PS125-15 ²	0.0158	70ksi	0.140	0.476	0.683	0.228	2.209	0.023	0.404	0.029	0.495	0.091	3827	0.012	0.161	-0.666	2.343	0.919	20.0
162PS125-18	0.0188	70ksi	0.084	0.286	0.040	0.049	0.687	0.018	0.464	0.036	0.033	0.027	1140	0.010	0.011	-1.085	1.365	0.369	20.9
250PS125-18	0.0188	70ksi	0.100	0.342	0.104	0.083	1.018	0.021	0.457	0.037	0.092	0.049	2059	0.012	0.027	-0.955	1.469	0.577	20.7
362PS125-18	0.0188	70ksi	0.122	0.414	0.244	0.135	1.418	0.024	0.441	0.037	0.194	0.065	2723	0.014	0.061	-0.833	1.703	0.761	20.5
400PS125-18	0.0188	70ksi	0.129	0.438	0.308	0.154	1.547	0.024	0.434	0.037	0.241	0.072	3028	0.015	0.076	-0.800	1.795	0.801	20.4
550PS125-18 ¹	0.0188	70ksi	0.157	0.534	0.656	0.239	2.045	0.026	0.410	0.037	0.503	0.108	4525	0.018	0.155	-0.692	2.198	0.901	20.1
600PS125-18 ¹	0.0188	70ksi	0.166	0.566	0.810	0.270	2.207	0.027	0.402	0.037	0.609	0.118	4946	0.020	0.190	-0.663	2.340	0.920	19.9
162PS125-22	0.0232	65ksi	0.103	0.351	0.048	0.059	0.685	0.022	0.462	0.051	0.042	0.037	1444	0.019	0.013	-1.079	1.359	0.369	21.7
250PS125-22	0.0232	65ksi	0.123	0.420	0.127	0.102	1.016	0.026	0.455	0.052	0.114	0.071	2765	0.022	0.033	-0.950	1.464	0.579	21.4
362PS125-22	0.0232	65ksi	0.150	0.509	0.300	0.166	1.417	0.029	0.438	0.052	0.252	0.091	3526	0.027	0.074	-0.828	1.699	0.762	21.2
400PS125-22	0.0232	65ksi	0.158	0.538	0.377	0.189	1.544	0.030	0.432	0.052	0.313	0.101	3924	0.028	0.092	-0.795	1.790	0.803	21.1
550PS125-22	0.0232	65ksi	0.193	0.657	0.805	0.293	2.043	0.032	0.408	0.053	0.662	0.152	5935	0.035	0.189	-0.688	2.193	0.902	20.7
600PS125-22	0.0232	65ksi	0.205	0.696	0.994	0.331	2.204	0.033	0.400	0.053	0.802	0.167	6495	0.037	0.231	-0.658	2.335	0.921	20.6
162PS125-26	0.0274	65ksi	0.121	0.412	0.056	0.070	0.683	0.026	0.460	0.065	0.051	0.046	1807	0.030	0.015	-1.074	1.353	0.370	21.7
250PS125-26	0.0274	65ksi	0.145	0.494	0.149	0.119	1.014	0.030	0.453	0.067	0.136	0.089	3465	0.036	0.038	-0.945	1.458	0.580	21.4
362PS125-26	0.0274	65ksi	0.176	0.599	0.352	0.194	1.413	0.033	0.436	0.067	0.305	0.115	4489	0.044	0.086	-0.824	1.693	0.763	21.1
400PS125-26	0.0274	65ksi	0.186	0.634	0.443	0.221	1.542	0.034	0.430	0.068	0.381	0.129	5008	0.047	0.107	-0.791	1.785	0.804	21.1
550PS125-26	0.0274	65ksi	0.227	0.774	0.946	0.344	2.040	0.037	0.406	0.068	0.811	0.196	7646	0.057	0.221	-0.683	2.189	0.903	20.7
600PS125-26	0.0274	65ksi	0.241	0.820	1.168	0.389	2.201	0.038	0.398	0.068	0.985	0.215	8375	0.060	0.269	-0.654	2.331	0.921	20.5
162PS125-30	0.0312	33ksi	0.137	0.468	0.064	0.078	0.681	0.029	0.458	0.098	0.063	0.067	1332	0.045	0.017	-1.070	1.348	0.371	30.8
250PS125-30	0.0312	33ksi	0.165	0.561	0.169	0.135	1.012	0.034	0.451	0.106	0.168	0.121	2383	0.053	0.042	-0.941	1.454	0.581	30.1
362PS125-30	0.0312	33ksi	0.200	0.680	0.398	0.220	1.411	0.038	0.434	0.107	0.385	0.176	3488	0.065	0.096	-0.820	1.689	0.764	29.7
400PS125-30	0.0312	33ksi	0.212	0.720	0.501	0.251	1.540	0.039	0.428	0.108	0.485	0.198	3910	0.069	0.120	-0.787	1.781	0.805	29.5
550PS125-30	0.0312	33ksi	0.258	0.879	1.072	0.390	2.037	0.042	0.404	0.109	1.048	0.307	6065	0.084	0.248	-0.680	2.185	0.903	28.9
600PS125-30	0.0312	33ksi	0.274	0.932	1.324	0.441	2.199	0.043	0.396	0.109	1.281	0.338	6671	0.089	0.303	-0.651	2.327	0.922	28.7
162PS125-33	0.0346	33ksi	0.152	0.517	0.070	0.086	0.679	0.032	0.456	0.114	0.069	0.078	1541	0.061	0.019	-1.065	1.344	0.371	30.8
250PS125-33	0.0346	33ksi	0.182	0.620	0.186	0.149	1.010	0.037	0.449	0.125	0.186	0.138	2735	0.073	0.046	-0.937	1.449	0.582	30.1
362PS125-33	0.0346	33ksi	0.221	0.752	0.439	0.242	1.409	0.041	0.433	0.127	0.426	0.207	4088	0.088	0.106	-0.816	1.685	0.766	29.6
400PS125-33	0.0346	33ksi	0.234	0.796	0.553	0.277	1.538	0.043	0.426	0.128	0.537	0.232	4590	0.093	0.132	-0.783	1.777	0.806	29.5
550PS125-33	0.0346	33ksi	0.286	0.973	1.184	0.430	2.035	0.046	0.402	0.130	1.167	0.362	7149	0.114	0.272	-0.676	2.182	0.904	28.9
600PS125-33	0.0346	33ksi	0.303	1.032	1.463	0.488	2.196	0.047	0.394	0.130	1.428	0.399	7875	0.121	0.332	-0.647	2.323	0.922	28.6

¹ Web-height to thickness ratio exceeds 200. Web Stiffeners are required at all support points and concentrated loads.

² Web-depth to thickness ratio exceeds 260. Web stiffeners are required at all bearing and intermediate locations, and no web holes are permitted in non-composite conditions

Section Properties

Section Properties Table Notes

1. Section properties were determined in accordance with AISI NASPEC 2001 w/ 2004 supplement.
2. Calculated effective moment of inertia (I_{xe}) is based on serviceability determination.
3. Effective properties and moment capacity did not incorporate stress increase as a result of cold work of forming.
4. Effective Properties are conservatively based upon the basic C-Section, improved values are possible by applying the AISI Direct Strength Method.
5. Allowable bending moment is based on a fully braced section about its major axis.

Non-Structural (PT) ProTRAK™ (1" Leg) Section Properties

Section	Design Thickness (in)	Yield Strength	Gross Properties							Effective Properties				Torsional				
			Area (in ²)	Weight (lb/ft)	I _x (in ⁴)	S _x (in ³)	R _x (in)	I _y (in ⁴)	R _y (in)	A _e (in ²)	I _{xe} (in ⁴)	S _{xe} (in ³)	M _a (in-lbs)	J ^{x1000} (in ⁴)	C _w (in ⁶)	X _o (in)	R _o (in)	β
162PT100-15	0.0158	50ksi	0.057	0.195	0.028	0.033	0.698	0.006	0.325	0.020	0.019	0.016	470	0.005	0.003	-0.659	1.014	0.578
162PT100-18	0.0188	50ksi	0.068	0.232	0.033	0.039	0.699	0.007	0.325	0.027	0.024	0.021	638	0.008	0.004	-0.657	1.013	0.579
162PT100-22	0.0232	50ksi	0.084	0.286	0.041	0.048	0.701	0.009	0.324	0.040	0.031	0.028	844	0.015	0.004	-0.655	1.012	0.582
162PT100-26	0.0274	50ksi	0.099	0.337	0.049	0.057	0.702	0.010	0.323	0.054	0.039	0.035	1060	0.025	0.005	-0.652	1.011	0.584
162PT100-30	0.0312	33ksi	0.113	0.384	0.056	0.065	0.703	0.012	0.322	0.078	0.049	0.046	908	0.037	0.006	-0.650	1.011	0.586
162PT100-33	0.0346	33ksi	0.125	0.426	0.062	0.072	0.704	0.013	0.322	0.093	0.056	0.053	1051	0.050	0.007	-0.649	1.010	0.588
250PT100-15	0.0158	50ksi	0.071	0.242	0.072	0.056	1.007	0.007	0.311	0.020	0.054	0.024	725	0.006	0.008	-0.566	1.197	0.776
250PT100-18	0.0188	50ksi	0.085	0.288	0.086	0.067	1.008	0.008	0.311	0.028	0.066	0.034	1014	0.010	0.009	-0.564	1.196	0.777
250PT100-22	0.0232	50ksi	0.104	0.355	0.106	0.082	1.009	0.010	0.310	0.041	0.084	0.052	1550	0.019	0.012	-0.562	1.196	0.779
250PT100-26	0.0274	50ksi	0.123	0.419	0.126	0.097	1.010	0.012	0.309	0.056	0.103	0.065	1959	0.031	0.014	-0.560	1.196	0.780
250PT100-30	0.0312	33ksi	0.140	0.477	0.143	0.110	1.011	0.013	0.308	0.083	0.127	0.083	1635	0.045	0.016	-0.559	1.196	0.782
250PT100-33	0.0346	33ksi	0.155	0.529	0.159	0.122	1.012	0.015	0.308	0.100	0.145	0.095	1878	0.062	0.017	-0.557	1.195	0.783
350PT100-15	0.0158	50ksi	0.087	0.296	0.156	0.088	1.341	0.007	0.294	0.021	0.112	0.034	1017	0.007	0.017	-0.490	1.458	0.887
350PT100-18	0.0188	50ksi	0.103	0.352	0.186	0.104	1.342	0.009	0.293	0.028	0.152	0.047	1411	0.012	0.020	-0.488	1.458	0.888
350PT100-22	0.0232	50ksi	0.128	0.434	0.230	0.128	1.343	0.011	0.292	0.042	0.192	0.071	2123	0.023	0.025	-0.487	1.458	0.889
350PT100-26	0.0274	50ksi	0.151	0.512	0.272	0.151	1.343	0.013	0.292	0.057	0.231	0.099	2977	0.038	0.030	-0.485	1.458	0.889
350PT100-30	0.0312	33ksi	0.171	0.583	0.310	0.172	1.344	0.015	0.291	0.086	0.279	0.135	2666	0.056	0.034	-0.483	1.458	0.890
350PT100-33	0.0346	33ksi	0.190	0.646	0.344	0.190	1.345	0.016	0.290	0.104	0.316	0.154	3044	0.076	0.037	-0.482	1.458	0.891
362PT100-15	0.0158	50ksi	0.089	0.302	0.170	0.092	1.382	0.008	0.292	0.021	0.120	0.035	1054	0.007	0.019	-0.482	1.492	0.896
362PT100-18	0.0188	50ksi	0.106	0.360	0.202	0.109	1.382	0.009	0.291	0.028	0.165	0.049	1461	0.012	0.022	-0.480	1.492	0.896
362PT100-22	0.0232	50ksi	0.130	0.444	0.250	0.135	1.384	0.011	0.290	0.042	0.210	0.073	2197	0.023	0.027	-0.478	1.493	0.897
362PT100-26	0.0274	50ksi	0.154	0.524	0.295	0.159	1.384	0.013	0.290	0.057	0.252	0.103	3071	0.039	0.032	-0.477	1.492	0.898
362PT100-30	0.0312	33ksi	0.175	0.596	0.336	0.180	1.385	0.015	0.289	0.086	0.303	0.142	2810	0.057	0.037	-0.475	1.492	0.899
362PT100-33	0.0346	33ksi	0.194	0.661	0.373	0.200	1.385	0.016	0.288	0.104	0.344	0.162	3206	0.078	0.040	-0.474	1.492	0.899
400PT100-15 ¹	0.0158	50ksi	0.095	0.323	0.214	0.105	1.503	0.008	0.286	0.021	0.138	0.038	1147	0.008	0.023	-0.459	1.597	0.917
400PT100-18	0.0188	50ksi	0.113	0.384	0.255	0.125	1.504	0.009	0.285	0.028	0.180	0.052	1570	0.013	0.028	-0.458	1.597	0.918
400PT100-22	0.0232	50ksi	0.139	0.473	0.315	0.154	1.504	0.011	0.284	0.042	0.244	0.076	2289	0.025	0.034	-0.456	1.598	0.918
400PT100-26	0.0274	50ksi	0.164	0.559	0.372	0.182	1.505	0.013	0.283	0.057	0.307	0.103	3072	0.041	0.040	-0.455	1.598	0.919
400PT100-30	0.0312	33ksi	0.187	0.636	0.424	0.207	1.506	0.015	0.283	0.087	0.388	0.148	2927	0.061	0.046	-0.453	1.598	0.920
400PT100-33	0.0346	33ksi	0.207	0.705	0.470	0.229	1.506	0.016	0.282	0.105	0.438	0.176	3469	0.083	0.051	-0.452	1.598	0.920
550PT100-15 ²	0.0158	50ksi	0.118	0.403	0.463	0.166	1.976	0.008	0.264	0.021	0.277	0.053	1595	0.010	0.049	-0.388	2.031	0.964
550PT100-18 ²	0.0188	50ksi	0.141	0.480	0.551	0.198	1.977	0.010	0.263	0.029	0.362	0.073	2190	0.017	0.058	-0.387	2.031	0.964
550PT100-22 ¹	0.0232	50ksi	0.174	0.592	0.680	0.243	1.977	0.012	0.262	0.043	0.498	0.107	3209	0.031	0.071	-0.385	2.032	0.964
550PT100-26	0.0274	50ksi	0.205	0.699	0.803	0.287	1.978	0.014	0.262	0.058	0.634	0.145	4332	0.051	0.083	-0.384	2.032	0.964
550PT100-30	0.0312	33ksi	0.234	0.795	0.915	0.327	1.978	0.016	0.261	0.088	0.819	0.213	4200	0.076	0.095	-0.383	2.032	0.965
550PT100-33	0.0346	33ksi	0.259	0.882	1.015	0.362	1.979	0.018	0.260	0.107	0.939	0.254	5015	0.103	0.105	-0.382	2.032	0.965
600PT100-15 ²	0.0158	50ksi	0.126	0.430	0.574	0.189	2.131	0.008	0.257	0.021	0.334	0.058	1744	0.011	0.059	-0.369	2.178	0.971
600PT100-18 ²	0.0188	50ksi	0.150	0.512	0.683	0.225	2.132	0.010	0.257	0.029	0.439	0.080	2396	0.018	0.070	-0.368	2.178	0.971
600PT100-22 ¹	0.0232	50ksi	0.186	0.631	0.843	0.277	2.132	0.012	0.256	0.043	0.604	0.117	3516	0.033	0.086	-0.367	2.178	0.972
600PT100-26 ¹	0.0274	50ksi	0.219	0.745	0.996	0.327	2.133	0.014	0.255	0.058	0.772	0.159	4751	0.055	0.102	-0.365	2.179	0.972
600PT100-30	0.0312	33ksi	0.249	0.849	1.135	0.372	2.133	0.016	0.255	0.088	1.004	0.234	4625	0.081	0.115	-0.364	2.179	0.972
600PT100-33	0.0346	33ksi	0.276	0.941	1.258	0.412	2.133	0.018	0.254	0.107	1.152	0.280	5531	0.110	0.127	-0.363	2.179	0.972

¹ Web-height to thickness ratio exceeds 200. Web Stiffeners are required at all support points and concentrated loads.

² Web-depth to thickness ratio exceeds 260. Web stiffeners are required at all bearing and intermediate locations, and no web holes are permitted in non-composite conditions

Section Properties

Section Properties Table Notes

1. Section properties were determined in accordance with AISI NASPEC 2001 w/ 2004 supplement.
2. Calculated effective moment of inertia (I_{xe}) is based on serviceability determination.
3. Effective properties and moment capacity did not incorporate stress increase as a result of cold work of forming.
4. Effective Properties are conservatively based upon the basic C-Section, improved values are possible by applying the AISI Direct Strength Method.
5. Allowable bending moment is based on a fully braced section about its major axis.

Non-Structural (PT) ProTRAK™ (1-1/4" Leg) Section Properties

Section	Design Thickness (in)	Yield Strength	Gross Properties							Effective Properties				Torsional				
			Area (in ²)	Weight (lb/ft)	I _x (in ⁴)	S _x (in ³)	R _x (in)	I _y (in ⁴)	R _y (in)	A _e (in ²)	I _{xe} (in ⁴)	S _{xe} (in ³)	Ma (in-lbs)	J ^{x1000} (in ⁴)	C _w (in ⁶)	X _o (in)	R _o (in)	β
162PT125-15	0.0158	50ksi	0.065	0.222	0.034	0.040	0.717	0.011	0.412	0.020	0.021	0.016	464	0.005	0.006	-0.881	1.208	0.468
162PT125-18	0.0188	50ksi	0.078	0.264	0.040	0.047	0.718	0.013	0.411	0.027	0.026	0.022	649	0.009	0.007	-0.879	1.208	0.470
162PT125-22	0.0232	50ksi	0.096	0.325	0.050	0.058	0.720	0.016	0.411	0.040	0.034	0.029	877	0.017	0.008	-0.877	1.206	0.472
162PT125-26	0.0274	50ksi	0.113	0.384	0.059	0.068	0.721	0.019	0.410	0.054	0.043	0.037	1103	0.028	0.010	-0.874	1.205	0.474
162PT125-30	0.0312	33ksi	0.128	0.437	0.067	0.078	0.722	0.022	0.409	0.080	0.054	0.048	951	0.042	0.011	-0.872	1.204	0.475
162PT125-33	0.0346	33ksi	0.142	0.485	0.075	0.086	0.723	0.024	0.409	0.095	0.063	0.056	1104	0.057	0.012	-0.870	1.203	0.477
250PT125-15	0.0158	50ksi	0.079	0.269	0.085	0.066	1.038	0.013	0.400	0.020	0.059	0.024	724	0.007	0.015	-0.771	1.353	0.675
250PT125-18	0.0188	50ksi	0.094	0.320	0.101	0.079	1.038	0.015	0.400	0.028	0.072	0.034	1008	0.011	0.017	-0.770	1.353	0.676
250PT125-22	0.0232	50ksi	0.116	0.394	0.125	0.097	1.040	0.018	0.399	0.041	0.092	0.051	1525	0.021	0.021	-0.767	1.352	0.678
250PT125-26	0.0274	50ksi	0.137	0.466	0.148	0.114	1.041	0.022	0.398	0.056	0.113	0.068	2042	0.034	0.025	-0.765	1.352	0.679
250PT125-30	0.0312	33ksi	0.156	0.530	0.169	0.130	1.042	0.025	0.397	0.084	0.140	0.087	1713	0.051	0.029	-0.763	1.351	0.681
250PT125-33	0.0346	33ksi	0.173	0.588	0.188	0.144	1.043	0.027	0.397	0.102	0.160	0.100	1972	0.069	0.032	-0.762	1.351	0.682
350PT125-15	0.0158	50ksi	0.095	0.323	0.181	0.101	1.383	0.014	0.383	0.021	0.116	0.034	1022	0.008	0.031	-0.678	1.587	0.818
350PT125-18	0.0188	50ksi	0.113	0.384	0.216	0.121	1.383	0.017	0.383	0.028	0.159	0.047	1416	0.013	0.037	-0.676	1.587	0.818
350PT125-22	0.0232	50ksi	0.139	0.473	0.267	0.149	1.384	0.020	0.382	0.042	0.209	0.071	2120	0.025	0.046	-0.674	1.587	0.819
350PT125-26	0.0274	50ksi	0.164	0.559	0.315	0.175	1.385	0.024	0.381	0.057	0.252	0.099	2952	0.041	0.054	-0.672	1.586	0.820
350PT125-30	0.0312	33ksi	0.187	0.636	0.359	0.199	1.386	0.027	0.380	0.087	0.304	0.141	2789	0.061	0.062	-0.671	1.586	0.821
350PT125-33	0.0346	33ksi	0.207	0.705	0.399	0.221	1.387	0.030	0.380	0.105	0.346	0.161	3189	0.083	0.068	-0.669	1.586	0.822
362PT125-15	0.0158	50ksi	0.097	0.329	0.196	0.106	1.425	0.014	0.381	0.021	0.125	0.035	1059	0.008	0.034	-0.668	1.619	0.830
362PT125-18	0.0188	50ksi	0.115	0.392	0.234	0.126	1.426	0.017	0.380	0.029	0.170	0.049	1467	0.014	0.040	-0.666	1.619	0.831
362PT125-22	0.0232	50ksi	0.142	0.483	0.290	0.156	1.428	0.020	0.379	0.042	0.228	0.073	2197	0.025	0.050	-0.664	1.620	0.832
362PT125-26	0.0274	50ksi	0.168	0.571	0.342	0.184	1.427	0.024	0.379	0.058	0.275	0.102	3052	0.042	0.059	-0.663	1.619	0.832
362PT125-30	0.0312	33ksi	0.191	0.649	0.389	0.209	1.428	0.027	0.378	0.087	0.330	0.149	2938	0.062	0.067	-0.661	1.619	0.833
362PT125-33	0.0346	33ksi	0.212	0.720	0.432	0.231	1.429	0.030	0.377	0.105	0.375	0.170	3358	0.084	0.074	-0.659	1.618	0.834
400PT125-15 ¹	0.0158	50ksi	0.103	0.349	0.247	0.121	1.550	0.014	0.374	0.021	0.153	0.039	1171	0.009	0.043	-0.640	1.718	0.861
400PT125-18	0.0188	50ksi	0.122	0.416	0.294	0.144	1.550	0.017	0.374	0.029	0.207	0.054	1621	0.014	0.051	-0.638	1.718	0.862
400PT125-22	0.0232	50ksi	0.151	0.513	0.363	0.178	1.551	0.021	0.373	0.042	0.290	0.081	2419	0.027	0.062	-0.636	1.718	0.863
400PT125-26	0.0274	50ksi	0.178	0.605	0.429	0.209	1.552	0.025	0.372	0.058	0.350	0.112	3352	0.045	0.074	-0.635	1.718	0.863
400PT125-30	0.0312	33ksi	0.203	0.689	0.489	0.238	1.553	0.028	0.371	0.088	0.417	0.172	3407	0.066	0.084	-0.633	1.718	0.864
400PT125-33	0.0346	33ksi	0.225	0.764	0.542	0.264	1.554	0.031	0.371	0.106	0.473	0.197	3887	0.090	0.093	-0.632	1.718	0.865
550PT125-15 ²	0.0158	50ksi	0.126	0.430	0.524	0.188	2.036	0.015	0.350	0.021	0.290	0.054	1611	0.011	0.089	-0.549	2.137	0.934
550PT125-18 ²	0.0188	50ksi	0.150	0.512	0.623	0.224	2.036	0.018	0.349	0.029	0.382	0.074	2217	0.018	0.105	-0.548	2.137	0.934
550PT125-22 ¹	0.0232	50ksi	0.186	0.631	0.770	0.276	2.037	0.023	0.349	0.043	0.527	0.109	3258	0.033	0.130	-0.546	2.138	0.935
550PT125-26	0.0274	50ksi	0.219	0.745	0.909	0.325	2.038	0.027	0.348	0.059	0.674	0.147	4409	0.055	0.153	-0.544	2.138	0.935
550PT125-30	0.0312	33ksi	0.249	0.849	1.036	0.370	2.038	0.030	0.347	0.089	0.880	0.218	4306	0.081	0.174	-0.543	2.138	0.935
550PT125-33	0.0346	33ksi	0.276	0.941	1.149	0.410	2.039	0.033	0.347	0.108	1.011	0.261	5157	0.110	0.192	-0.542	2.138	0.936
600PT125-15 ²	0.0158	50ksi	0.134	0.457	0.646	0.213	2.194	0.016	0.343	0.021	0.350	0.059	1762	0.011	0.108	-0.524	2.282	0.947
600PT125-18 ²	0.0188	50ksi	0.160	0.544	0.769	0.253	2.195	0.019	0.342	0.029	0.461	0.081	2425	0.019	0.129	-0.523	2.282	0.947
600PT125-22 ¹	0.0232	50ksi	0.197	0.671	0.950	0.312	2.195	0.023	0.341	0.043	0.638	0.119	3568	0.035	0.158	-0.522	2.282	0.948
600PT125-26 ¹	0.0274	50ksi	0.233	0.792	1.122	0.368	2.196	0.027	0.340	0.059	0.819	0.161	4833	0.058	0.187	-0.520	2.282	0.948
600PT125-30	0.0312	33ksi	0.265	0.902	1.278	0.419	2.196	0.031	0.340	0.090	1.074	0.240	4737	0.086	0.212	-0.519	2.282	0.948
600PT125-33	0.0346	33ksi	0.294	1.000	1.418	0.464	2.197	0.034	0.339	0.109	1.237	0.287	5681	0.117	0.234	-0.517	2.282	0.949

¹ Web-height to thickness ratio exceeds 200. Web Stiffeners are required at all support points and concentrated loads.

² Web-depth to thickness ratio exceeds 260. Web stiffeners are required at all bearing and intermediate locations, and no web holes are permitted in non-composite conditions

Section Properties

Section Properties Table Notes

1. Section properties were determined in accordance with AISI NASPEC 2001 w/ 2004 supplement.
2. Calculated effective moment of inertia (I_{xe}) is based on serviceability determination.
3. Effective properties and moment capacity did not incorporate stress increase as a result of cold work of forming.
4. Effective Properties are conservatively based upon the basic C-Section, improved values are possible by applying the AISI Direct Strength Method.
5. Allowable bending moment is based on a fully braced section about its major axis.

Non-Structural (PT) ProTRAK™ (1-1/2" Leg) Section Properties

Section	Design Thickness (in)	Yield Strength	Gross Properties							Effective Properties				Torsional				
			Area (in ²)	Weight (lb/ft)	I _x (in ⁴)	S _x (in ³)	R _x (in)	I _y (in ⁴)	R _y (in)	A _e (in ²)	I _{xe} (in ⁴)	S _{xe} (in ³)	Ma (in-lbs)	J ^{x1000} (in ⁴)	C _w (in ⁶)	X _o (in)	R _o (in)	β
162PT150-15	0.0158	50ksi	0.073	0.249	0.039	0.046	0.731	0.018	0.497	0.020	0.023	0.015	460	0.006	0.009	-1.110	1.419	0.388
162PT150-18	0.0188	50ksi	0.087	0.296	0.047	0.055	0.733	0.021	0.496	0.028	0.028	0.021	640	0.010	0.011	-1.108	1.418	0.389
162PT150-22	0.0232	50ksi	0.107	0.365	0.058	0.068	0.734	0.026	0.496	0.040	0.037	0.030	902	0.019	0.013	-1.105	1.417	0.391
162PT150-26	0.0274	50ksi	0.127	0.431	0.068	0.080	0.736	0.031	0.495	0.054	0.046	0.038	1136	0.032	0.016	-1.103	1.415	0.393
162PT150-30	0.0312	33ksi	0.144	0.490	0.078	0.091	0.737	0.035	0.494	0.080	0.059	0.050	983	0.047	0.018	-1.101	1.414	0.394
162PT150-33	0.0346	33ksi	0.160	0.543	0.087	0.100	0.738	0.039	0.494	0.096	0.068	0.058	1143	0.064	0.020	-1.099	1.413	0.395
250PT150-15	0.0158	50ksi	0.087	0.296	0.098	0.076	1.062	0.021	0.489	0.020	0.061	0.024	723	0.007	0.024	-0.985	1.529	0.585
250PT150-18	0.0188	50ksi	0.103	0.352	0.117	0.091	1.063	0.025	0.488	0.028	0.078	0.034	1003	0.012	0.028	-0.984	1.528	0.586
250PT150-22	0.0232	50ksi	0.128	0.434	0.144	0.112	1.064	0.030	0.487	0.042	0.100	0.050	1508	0.023	0.035	-0.981	1.527	0.587
250PT150-26	0.0274	50ksi	0.151	0.512	0.171	0.132	1.065	0.036	0.486	0.057	0.121	0.070	2104	0.038	0.041	-0.979	1.526	0.588
250PT150-30	0.0312	33ksi	0.171	0.583	0.195	0.150	1.066	0.040	0.486	0.085	0.151	0.090	1773	0.056	0.047	-0.977	1.526	0.590
250PT150-33	0.0346	33ksi	0.190	0.646	0.216	0.166	1.067	0.045	0.485	0.102	0.173	0.103	2044	0.076	0.052	-0.975	1.525	0.591
350PT150-15	0.0158	50ksi	0.103	0.349	0.206	0.115	1.417	0.023	0.473	0.021	0.120	0.034	1024	0.009	0.051	-0.877	1.732	0.744
350PT150-18	0.0188	50ksi	0.122	0.416	0.246	0.137	1.418	0.027	0.472	0.029	0.163	0.047	1418	0.014	0.061	-0.875	1.732	0.745
350PT150-22	0.0232	50ksi	0.151	0.513	0.303	0.169	1.419	0.033	0.471	0.042	0.224	0.071	2117	0.027	0.075	-0.873	1.731	0.746
350PT150-26	0.0274	50ksi	0.178	0.605	0.359	0.200	1.420	0.039	0.470	0.058	0.271	0.098	2933	0.045	0.089	-0.871	1.731	0.747
350PT150-30	0.0312	33ksi	0.203	0.689	0.409	0.227	1.421	0.045	0.470	0.088	0.326	0.146	2887	0.066	0.101	-0.869	1.731	0.748
350PT150-33	0.0346	33ksi	0.225	0.764	0.454	0.252	1.422	0.049	0.469	0.106	0.372	0.167	3306	0.090	0.112	-0.868	1.730	0.749
362PT150-15	0.0158	50ksi	0.105	0.356	0.223	0.121	1.460	0.023	0.470	0.021	0.129	0.035	1061	0.009	0.056	-0.865	1.761	0.759
362PT150-18	0.0188	50ksi	0.125	0.424	0.266	0.144	1.461	0.027	0.470	0.029	0.175	0.049	1469	0.015	0.066	-0.863	1.761	0.760
362PT150-22	0.0232	50ksi	0.154	0.523	0.329	0.177	1.463	0.034	0.469	0.042	0.244	0.073	2195	0.028	0.082	-0.861	1.761	0.761
362PT150-26	0.0274	50ksi	0.181	0.617	0.388	0.209	1.463	0.040	0.468	0.058	0.295	0.101	3036	0.045	0.096	-0.859	1.760	0.762
362PT150-30	0.0312	33ksi	0.206	0.703	0.443	0.237	1.464	0.045	0.468	0.088	0.354	0.154	3042	0.067	0.109	-0.858	1.760	0.763
362PT150-33	0.0346	33ksi	0.229	0.779	0.491	0.263	1.465	0.050	0.467	0.106	0.403	0.176	3481	0.091	0.121	-0.856	1.760	0.763
400PT150-15 ¹	0.0158	50ksi	0.111	0.376	0.279	0.137	1.589	0.024	0.464	0.021	0.158	0.039	1175	0.009	0.070	-0.832	1.852	0.798
400PT150-18	0.0188	50ksi	0.132	0.448	0.332	0.163	1.589	0.028	0.463	0.029	0.214	0.054	1625	0.015	0.083	-0.830	1.852	0.799
400PT150-22	0.0232	50ksi	0.162	0.552	0.411	0.201	1.590	0.035	0.462	0.043	0.311	0.081	2422	0.029	0.102	-0.828	1.852	0.800
400PT150-26	0.0274	50ksi	0.192	0.652	0.485	0.237	1.591	0.041	0.462	0.058	0.375	0.112	3345	0.048	0.120	-0.826	1.852	0.801
400PT150-30	0.0312	33ksi	0.218	0.742	0.553	0.270	1.592	0.046	0.461	0.088	0.446	0.178	3526	0.071	0.137	-0.825	1.851	0.802
400PT150-33	0.0346	33ksi	0.242	0.823	0.614	0.299	1.593	0.051	0.460	0.107	0.507	0.204	4027	0.097	0.152	-0.823	1.851	0.802
550PT150-15 ²	0.0158	50ksi	0.134	0.457	0.585	0.210	2.087	0.026	0.438	0.021	0.307	0.054	1628	0.011	0.145	-0.722	2.251	0.897
550PT150-18 ²	0.0188	50ksi	0.160	0.544	0.696	0.250	2.087	0.031	0.438	0.029	0.412	0.075	2250	0.019	0.172	-0.721	2.251	0.897
550PT150-22 ¹	0.0232	50ksi	0.197	0.671	0.859	0.308	2.088	0.038	0.437	0.043	0.591	0.112	3342	0.035	0.212	-0.719	2.251	0.898
550PT150-26	0.0274	50ksi	0.233	0.792	1.016	0.363	2.089	0.044	0.436	0.059	0.803	0.153	4588	0.058	0.250	-0.718	2.251	0.898
550PT150-30	0.0312	33ksi	0.265	0.902	1.157	0.413	2.090	0.050	0.435	0.090	0.979	0.241	4766	0.086	0.284	-0.716	2.251	0.899
550PT150-33	0.0346	33ksi	0.294	1.000	1.284	0.458	2.090	0.055	0.435	0.109	1.098	0.299	5906	0.117	0.315	-0.715	2.251	0.899
600PT150-15 ²	0.0158	50ksi	0.142	0.484	0.719	0.237	2.249	0.026	0.430	0.021	0.363	0.059	1774	0.012	0.177	-0.692	2.392	0.916
600PT150-18 ²	0.0188	50ksi	0.169	0.576	0.856	0.282	2.249	0.031	0.429	0.029	0.481	0.082	2445	0.020	0.211	-0.691	2.392	0.916
600PT150-22 ¹	0.0232	50ksi	0.209	0.710	1.056	0.347	2.250	0.038	0.429	0.043	0.668	0.120	3604	0.037	0.259	-0.690	2.392	0.917
600PT150-26 ¹	0.0274	50ksi	0.246	0.839	1.248	0.410	2.251	0.045	0.428	0.059	0.860	0.163	4891	0.062	0.306	-0.688	2.392	0.917
600PT150-30	0.0312	33ksi	0.281	0.955	1.422	0.466	2.251	0.051	0.427	0.090	1.136	0.244	4818	0.091	0.347	-0.686	2.392	0.918
600PT150-33	0.0346	33ksi	0.311	1.059	1.578	0.516	2.252	0.057	0.426	0.110	1.311	0.293	5790	0.124	0.384	-0.685	2.392	0.918

¹ Web-height to thickness ratio exceeds 200. Web Stiffeners are required at all support points and concentrated loads.

² Web-depth to thickness ratio exceeds 260. Web stiffeners are required at all bearing and intermediate locations, and no web holes are permitted in non-composite conditions

Section Properties

Section Properties Table Notes

1. Section properties were determined in accordance with AISI NASPEC 2001 w/ 2004 supplement.
2. Calculated effective moment of inertia (I_{xe}) is based on serviceability determination.
3. Effective properties and moment capacity did not incorporate stress increase as a result of cold work of forming.
4. Effective Properties are conservatively based upon the basic C-Section, improved values are possible by applying the AISI Direct Strength Method.
5. Allowable bending moment is based on a fully braced section about its major axis.

Non-Structural (PT) ProTRAK™ (2" Leg) Section Properties

Section	Design Thickness (in)	Yield Strength	Gross Properties							Effective Properties				Torsional				
			Area (in ²)	Weight (lb/ft)	I _x (in ⁴)	S _x (in ³)	R _x (in)	I _y (in ⁴)	R _y (in)	A _e (in ²)	I _{xe} (in ⁴)	S _{xe} (in ³)	Ma (in-lbs)	J ^{x1000} (in ⁴)	C _w (in ⁶)	X _o (in)	R _o (in)	β
162PT200-15	0.0158	50ksi	0.089	0.302	0.050	0.059	0.752	0.039	0.663	0.020	0.025	0.015	455	0.007	0.020	-1.579	1.870	0.287
162PT200-18	0.0188	50ksi	0.106	0.360	0.060	0.070	0.753	0.046	0.662	0.028	0.032	0.021	629	0.012	0.024	-1.577	1.869	0.288
162PT200-22	0.0232	50ksi	0.130	0.444	0.074	0.087	0.755	0.057	0.661	0.041	0.041	0.031	935	0.023	0.030	-1.574	1.867	0.289
162PT200-26	0.0274	50ksi	0.154	0.524	0.088	0.102	0.756	0.067	0.661	0.055	0.052	0.040	1183	0.039	0.035	-1.572	1.865	0.290
162PT200-30	0.0312	33ksi	0.175	0.596	0.101	0.117	0.758	0.076	0.660	0.081	0.067	0.052	1028	0.057	0.040	-1.570	1.864	0.291
162PT200-33	0.0346	33ksi	0.194	0.661	0.112	0.129	0.759	0.085	0.660	0.097	0.077	0.061	1198	0.078	0.045	-1.568	1.862	0.292
250PT200-15	0.0158	50ksi	0.103	0.349	0.124	0.096	1.098	0.045	0.662	0.021	0.064	0.024	720	0.009	0.052	-1.431	1.921	0.445
250PT200-18	0.0188	50ksi	0.122	0.416	0.147	0.114	1.099	0.053	0.661	0.028	0.086	0.033	996	0.014	0.062	-1.430	1.920	0.446
250PT200-22	0.0232	50ksi	0.151	0.513	0.182	0.141	1.100	0.066	0.660	0.042	0.112	0.050	1485	0.027	0.076	-1.427	1.919	0.447
250PT200-26	0.0274	50ksi	0.178	0.605	0.216	0.166	1.102	0.077	0.660	0.057	0.137	0.069	2053	0.045	0.090	-1.425	1.918	0.448
250PT200-30	0.0312	33ksi	0.203	0.689	0.246	0.189	1.103	0.088	0.659	0.086	0.170	0.094	1862	0.066	0.103	-1.423	1.917	0.449
250PT200-33	0.0346	33ksi	0.225	0.764	0.274	0.210	1.104	0.097	0.658	0.104	0.196	0.109	2150	0.090	0.114	-1.421	1.916	0.450
350PT200-15	0.0158	50ksi	0.118	0.403	0.256	0.143	1.470	0.050	0.650	0.021	0.127	0.034	1025	0.010	0.111	-1.297	2.066	0.606
350PT200-18	0.0188	50ksi	0.141	0.480	0.305	0.171	1.471	0.059	0.650	0.029	0.171	0.047	1418	0.017	0.132	-1.295	2.065	0.607
350PT200-22	0.0232	50ksi	0.174	0.592	0.377	0.210	1.473	0.073	0.649	0.043	0.249	0.070	2109	0.031	0.163	-1.293	2.064	0.608
350PT200-26	0.0274	50ksi	0.205	0.699	0.446	0.248	1.474	0.086	0.648	0.058	0.304	0.097	2905	0.051	0.193	-1.291	2.064	0.609
350PT200-30	0.0312	33ksi	0.234	0.795	0.509	0.282	1.475	0.098	0.647	0.088	0.365	0.154	3039	0.076	0.219	-1.289	2.063	0.610
350PT200-33	0.0346	33ksi	0.259	0.882	0.565	0.313	1.476	0.108	0.647	0.107	0.417	0.176	3484	0.103	0.243	-1.287	2.062	0.610
362PT200-15	0.0158	50ksi	0.120	0.410	0.277	0.150	1.516	0.051	0.648	0.021	0.137	0.036	1063	0.010	0.120	-1.282	2.088	0.623
362PT200-18	0.0188	50ksi	0.143	0.488	0.330	0.178	1.517	0.060	0.648	0.029	0.184	0.049	1470	0.017	0.143	-1.281	2.088	0.624
362PT200-22	0.0232	50ksi	0.177	0.602	0.408	0.220	1.519	0.074	0.647	0.043	0.268	0.073	2189	0.032	0.177	-1.278	2.088	0.625
362PT200-26	0.0274	50ksi	0.209	0.710	0.482	0.259	1.519	0.087	0.646	0.058	0.331	0.101	3011	0.052	0.209	-1.276	2.086	0.626
362PT200-30	0.0312	33ksi	0.238	0.809	0.549	0.295	1.520	0.099	0.645	0.089	0.397	0.160	3159	0.077	0.237	-1.274	2.086	0.627
362PT200-33	0.0346	33ksi	0.264	0.897	0.610	0.327	1.521	0.110	0.645	0.107	0.452	0.186	3669	0.105	0.263	-1.272	2.085	0.628
400PT200-15 ¹	0.0158	50ksi	0.126	0.430	0.344	0.169	1.650	0.052	0.642	0.021	0.168	0.039	1178	0.011	0.151	-1.240	2.162	0.671
400PT200-18	0.0188	50ksi	0.150	0.512	0.410	0.201	1.651	0.062	0.642	0.029	0.225	0.054	1629	0.018	0.179	-1.238	2.161	0.672
400PT200-22	0.0232	50ksi	0.186	0.631	0.506	0.248	1.652	0.076	0.641	0.043	0.326	0.081	2421	0.033	0.221	-1.236	2.161	0.673
400PT200-26	0.0274	50ksi	0.219	0.745	0.599	0.292	1.653	0.090	0.640	0.059	0.420	0.111	3330	0.055	0.261	-1.234	2.160	0.674
400PT200-30	0.0312	33ksi	0.249	0.849	0.682	0.333	1.654	0.102	0.639	0.089	0.502	0.176	3480	0.081	0.297	-1.232	2.160	0.674
400PT200-33	0.0346	33ksi	0.276	0.941	0.758	0.369	1.655	0.113	0.639	0.108	0.567	0.215	4246	0.110	0.329	-1.230	2.159	0.675
550PT200-15 ²	0.0158	50ksi	0.150	0.511	0.707	0.254	2.170	0.057	0.617	0.021	0.325	0.055	1637	0.012	0.314	-1.098	2.509	0.809
550PT200-18 ²	0.0188	50ksi	0.179	0.608	0.841	0.302	2.171	0.068	0.616	0.029	0.436	0.076	2264	0.021	0.373	-1.096	2.509	0.809
550PT200-22 ¹	0.0232	50ksi	0.220	0.750	1.039	0.372	2.172	0.083	0.615	0.043	0.623	0.112	3361	0.040	0.460	-1.094	2.508	0.810
550PT200-26	0.0274	50ksi	0.260	0.885	1.228	0.439	2.173	0.098	0.614	0.059	0.836	0.154	4610	0.065	0.542	-1.093	2.508	0.810
550PT200-30	0.0312	33ksi	0.296	1.008	1.399	0.499	2.174	0.112	0.614	0.091	1.091	0.240	4747	0.096	0.617	-1.091	2.508	0.811
550PT200-33	0.0346	33ksi	0.328	1.117	1.553	0.554	2.174	0.123	0.613	0.110	1.226	0.296	5847	0.131	0.683	-1.089	2.508	0.811
600PT200-15 ²	0.0158	50ksi	0.158	0.538	0.864	0.285	2.338	0.058	0.608	0.021	0.389	0.060	1789	0.013	0.383	-1.058	2.638	0.839
600PT200-18 ²	0.0188	50ksi	0.188	0.640	1.028	0.338	2.339	0.069	0.607	0.029	0.522	0.083	2475	0.022	0.456	-1.057	2.637	0.839
600PT200-22 ¹	0.0232	50ksi	0.232	0.789	1.270	0.417	2.340	0.085	0.606	0.043	0.746	0.123	3675	0.042	0.562	-1.055	2.637	0.840
600PT200-26 ¹	0.0274	50ksi	0.274	0.932	1.500	0.492	2.341	0.100	0.606	0.059	0.996	0.168	5038	0.069	0.663	-1.053	2.637	0.841
600PT200-30	0.0312	33ksi	0.312	1.061	1.710	0.560	2.342	0.114	0.605	0.091	1.353	0.262	5170	0.101	0.754	-1.051	2.637	0.841
600PT200-33	0.0346	33ksi	0.346	1.176	1.897	0.621	2.342	0.126	0.604	0.111	1.520	0.322	6355	0.138	0.835	-1.050	2.637	0.842

¹ Web-height to thickness ratio exceeds 200. Web Stiffeners are required at all support points and concentrated loads.

² Web-depth to thickness ratio exceeds 260. Web stiffeners are required at all bearing and intermediate locations, and no web holes are permitted in non-composite conditions

Section Properties

Section Properties Table Notes

1. Section properties were determined in accordance with AISI NASPEC 2001 w/ 2004 supplement.
2. Calculated effective moment of inertia (I_{xe}) is based on serviceability determination.
3. Effective properties and moment capacity did not incorporate stress increase as a result of cold work of forming.
4. Effective Properties are conservatively based upon the basic C-Section, improved values are possible by applying the AISI Direct Strength Method.
5. Allowable bending moment is based on a fully braced section about its major axis.

Non-Structural (PT) ProTRAK™ (2-1/2" Leg) Section Properties

Section	Design Thickness (in)	Yield Strength	Gross Properties							Effective Properties				Torsional				
			Area (in ²)	Weight (lb/ft)	I _x (in ⁴)	S _x (in ³)	R _x (in)	I _y (in ⁴)	R _y (in)	A _e (in ²)	I _{xe} (in ⁴)	S _{xe} (in ³)	Ma (in-lbs)	J ^{x1000} (in ⁴)	C _w (in ⁶)	X _o (in)	R _o (in)	β
162PT250-15	0.0158	50ksi	0.105	0.356	0.061	0.072	0.766	0.071	0.824	0.020	0.027	0.015	455	0.009	0.038	-2.058	2.345	0.230
162PT250-18	0.0188	50ksi	0.125	0.424	0.073	0.086	0.767	0.084	0.823	0.028	0.034	0.021	623	0.015	0.045	-2.056	2.344	0.231
162PT250-22	0.0232	50ksi	0.154	0.523	0.091	0.106	0.769	0.104	0.823	0.041	0.045	0.031	921	0.028	0.055	-2.053	2.342	0.231
162PT250-26	0.0274	50ksi	0.181	0.617	0.108	0.125	0.771	0.123	0.822	0.055	0.056	0.041	1215	0.045	0.066	-2.050	2.340	0.232
162PT250-30	0.0312	33ksi	0.206	0.703	0.123	0.143	0.772	0.139	0.821	0.082	0.073	0.054	1059	0.067	0.075	-2.048	2.338	0.233
162PT250-33	0.0346	33ksi	0.229	0.779	0.137	0.158	0.774	0.154	0.821	0.098	0.085	0.063	1235	0.091	0.083	-2.046	2.336	0.233
250PT250-15	0.0158	50ksi	0.118	0.403	0.150	0.116	1.123	0.082	0.831	0.021	0.066	0.024	725	0.010	0.096	-1.892	2.352	0.353
250PT250-18	0.0188	50ksi	0.141	0.480	0.178	0.138	1.124	0.097	0.830	0.028	0.089	0.033	991	0.017	0.114	-1.891	2.351	0.353
250PT250-22	0.0232	50ksi	0.174	0.592	0.221	0.171	1.126	0.120	0.829	0.042	0.122	0.049	1472	0.031	0.141	-1.888	2.350	0.354
250PT250-26	0.0274	50ksi	0.205	0.699	0.261	0.201	1.128	0.141	0.829	0.057	0.150	0.068	2022	0.051	0.167	-1.886	2.348	0.355
250PT250-30	0.0312	33ksi	0.234	0.795	0.298	0.229	1.129	0.160	0.828	0.086	0.186	0.097	1926	0.076	0.190	-1.883	2.347	0.356
250PT250-33	0.0346	33ksi	0.259	0.882	0.331	0.254	1.130	0.177	0.827	0.104	0.214	0.113	2225	0.103	0.211	-1.881	2.346	0.357
350PT250-15	0.0158	50ksi	0.134	0.457	0.306	0.171	1.510	0.091	0.825	0.021	0.132	0.035	1034	0.011	0.203	-1.737	2.445	0.495
350PT250-18	0.0188	50ksi	0.160	0.544	0.365	0.204	1.511	0.108	0.824	0.029	0.179	0.047	1416	0.019	0.242	-1.736	2.444	0.496
350PT250-22	0.0232	50ksi	0.197	0.671	0.451	0.251	1.512	0.134	0.823	0.043	0.258	0.070	2102	0.035	0.298	-1.733	2.443	0.497
350PT250-26	0.0274	50ksi	0.233	0.792	0.533	0.297	1.514	0.157	0.822	0.058	0.332	0.096	2885	0.058	0.353	-1.731	2.442	0.498
350PT250-30	0.0312	33ksi	0.265	0.902	0.608	0.338	1.515	0.179	0.822	0.089	0.401	0.151	2987	0.086	0.402	-1.729	2.441	0.498
350PT250-33	0.0346	33ksi	0.294	1.000	0.675	0.374	1.516	0.198	0.821	0.108	0.455	0.183	3616	0.117	0.446	-1.727	2.440	0.499
362PT250-15	0.0158	50ksi	0.136	0.464	0.330	0.179	1.557	0.092	0.823	0.021	0.142	0.036	1073	0.011	0.220	-1.720	2.462	0.512
362PT250-18	0.0188	50ksi	0.162	0.552	0.393	0.212	1.558	0.110	0.823	0.029	0.192	0.049	1469	0.019	0.262	-1.718	2.461	0.512
362PT250-22	0.0232	50ksi	0.200	0.681	0.487	0.262	1.560	0.135	0.822	0.043	0.277	0.073	2183	0.036	0.324	-1.716	2.460	0.514
362PT250-26	0.0274	50ksi	0.236	0.804	0.575	0.309	1.561	0.159	0.821	0.058	0.361	0.100	2993	0.059	0.382	-1.714	2.459	0.514
362PT250-30	0.0312	33ksi	0.269	0.915	0.656	0.352	1.562	0.181	0.820	0.089	0.436	0.157	3097	0.087	0.435	-1.712	2.458	0.515
362PT250-33	0.0346	33ksi	0.298	1.014	0.728	0.390	1.563	0.200	0.820	0.108	0.493	0.193	3808	0.119	0.482	-1.710	2.457	0.516
400PT250-15 ¹	0.0158	50ksi	0.142	0.484	0.409	0.201	1.696	0.095	0.819	0.021	0.174	0.040	1189	0.012	0.275	-1.670	2.517	0.560
400PT250-18	0.0188	50ksi	0.169	0.576	0.487	0.239	1.697	0.113	0.818	0.029	0.235	0.054	1629	0.020	0.327	-1.669	2.517	0.560
400PT250-22	0.0232	50ksi	0.209	0.710	0.602	0.295	1.698	0.139	0.817	0.043	0.338	0.081	2418	0.037	0.404	-1.666	2.516	0.561
400PT250-26	0.0274	50ksi	0.246	0.839	0.712	0.348	1.700	0.164	0.817	0.059	0.455	0.111	3317	0.062	0.477	-1.664	2.515	0.562
400PT250-30	0.0312	33ksi	0.281	0.955	0.812	0.396	1.701	0.187	0.816	0.090	0.551	0.173	3425	0.091	0.543	-1.662	2.514	0.563
400PT250-33	0.0346	33ksi	0.311	1.059	0.901	0.439	1.702	0.207	0.815	0.109	0.622	0.214	4221	0.124	0.602	-1.660	2.514	0.564
550PT250-15 ²	0.0158	50ksi	0.166	0.564	0.829	0.297	2.235	0.105	0.795	0.021	0.337	0.055	1654	0.014	0.570	-1.500	2.807	0.714
550PT250-18 ²	0.0188	50ksi	0.197	0.672	0.987	0.354	2.236	0.125	0.795	0.029	0.455	0.076	2269	0.023	0.678	-1.499	2.807	0.715
550PT250-22 ¹	0.0232	50ksi	0.244	0.829	1.218	0.436	2.237	0.154	0.794	0.043	0.651	0.113	3369	0.044	0.836	-1.496	2.806	0.716
550PT250-26	0.0274	50ksi	0.288	0.978	1.440	0.515	2.238	0.181	0.793	0.059	0.868	0.154	4617	0.072	0.987	-1.494	2.806	0.716
550PT250-30	0.0312	33ksi	0.327	1.114	1.641	0.586	2.239	0.206	0.793	0.091	1.190	0.239	4727	0.106	1.124	-1.493	2.805	0.717
550PT250-33	0.0346	33ksi	0.363	1.235	1.821	0.649	2.240	0.228	0.792	0.111	1.339	0.294	5802	0.145	1.246	-1.491	2.805	0.717
600PT250-15 ²	0.0158	50ksi	0.174	0.591	1.009	0.332	2.409	0.108	0.787	0.021	0.404	0.060	1809	0.014	0.697	-1.452	2.921	0.753
600PT250-18 ²	0.0188	50ksi	0.207	0.704	1.201	0.395	2.410	0.128	0.786	0.029	0.545	0.083	2483	0.024	0.829	-1.450	2.920	0.753
600PT250-22 ¹	0.0232	50ksi	0.255	0.868	1.483	0.487	2.411	0.157	0.785	0.043	0.779	0.123	3687	0.046	1.022	-1.448	2.920	0.754
600PT250-26 ¹	0.0274	50ksi	0.301	1.025	1.753	0.575	2.412	0.185	0.785	0.060	1.038	0.169	5051	0.075	1.206	-1.446	2.920	0.755
600PT250-30	0.0312	33ksi	0.343	1.167	1.997	0.655	2.413	0.211	0.784	0.092	1.473	0.261	5162	0.111	1.373	-1.444	2.919	0.755
600PT250-33	0.0346	33ksi	0.380	1.294	2.216	0.725	2.414	0.233	0.783	0.111	1.657	0.320	6327	0.152	1.522	-1.443	2.919	0.756

¹ Web-height to thickness ratio exceeds 200. Web Stiffeners are required at all support points and concentrated loads.

² Web-depth to thickness ratio exceeds 260. Web stiffeners are required at all bearing and intermediate locations, and no web holes are permitted in non-composite conditions

Section Properties

Section Properties Table Notes

1. Section properties were determined in accordance with AISI NASPEC 2001 w/ 2004 supplement.
2. Calculated effective moment of inertia (I_{xe}) is based on serviceability determination.
3. Effective properties and moment capacity did not incorporate stress increase as a result of cold work of forming.
4. Effective Properties are conservatively based upon the basic C-Section, improved values are possible by applying the AISI Direct Strength Method.
5. Allowable bending moment is based on a fully braced section about its major axis.

Non-Structural (PT) ProTRAK™ (3" Leg) Section Properties

Section	Design Thickness (in)	Yield Strength	Gross Properties							Effective Properties				Torsional				
			Area (in ²)	Weight (lb/ft)	I _x (in ⁴)	S _x (in ³)	R _x (in)	I _y (in ⁴)	R _y (in)	A _e (in ²)	I _{xe} (in ⁴)	S _{xe} (in ³)	Ma (in-lbs)	J ¹⁰⁰⁰ (in ⁴)	C _w (in ⁶)	X _o (in)	R _o (in)	β
162PT300-15	0.0158	50ksi	0.120	0.410	0.073	0.086	0.776	0.116	0.981	0.020	0.027	0.016	465	0.010	0.063	-2.542	2.834	0.195
162PT300-18	0.0188	50ksi	0.143	0.488	0.087	0.102	0.777	0.138	0.981	0.028	0.036	0.021	635	0.017	0.075	-2.540	2.832	0.195
162PT300-22	0.0232	50ksi	0.177	0.602	0.107	0.125	0.779	0.170	0.980	0.041	0.048	0.030	912	0.032	0.093	-2.538	2.830	0.196
162PT300-26	0.0274	50ksi	0.209	0.710	0.127	0.148	0.781	0.200	0.980	0.055	0.059	0.041	1239	0.052	0.110	-2.535	2.828	0.196
162PT300-30	0.0312	33ksi	0.238	0.809	0.146	0.169	0.783	0.228	0.979	0.082	0.078	0.055	1081	0.077	0.125	-2.532	2.826	0.197
162PT300-33	0.0346	33ksi	0.264	0.897	0.162	0.187	0.784	0.252	0.979	0.098	0.091	0.064	1262	0.105	0.139	-2.530	2.824	0.197
250PT300-15	0.0158	50ksi	0.134	0.457	0.175	0.136	1.143	0.133	0.996	0.021	0.067	0.025	748	0.011	0.158	-2.363	2.807	0.291
250PT300-18	0.0188	50ksi	0.160	0.544	0.209	0.162	1.144	0.158	0.995	0.028	0.092	0.033	996	0.019	0.189	-2.361	2.806	0.292
250PT300-22	0.0232	50ksi	0.197	0.671	0.259	0.200	1.145	0.195	0.994	0.042	0.131	0.049	1462	0.035	0.233	-2.359	2.804	0.293
250PT300-26	0.0274	50ksi	0.233	0.792	0.306	0.236	1.147	0.230	0.994	0.057	0.160	0.067	2003	0.058	0.276	-2.356	2.803	0.293
250PT300-30	0.0312	33ksi	0.265	0.902	0.350	0.269	1.149	0.261	0.993	0.087	0.199	0.100	1973	0.086	0.315	-2.354	2.801	0.294
250PT300-33	0.0346	33ksi	0.294	1.000	0.388	0.298	1.150	0.289	0.993	0.105	0.229	0.115	2282	0.117	0.349	-2.352	2.800	0.294
350PT300-15	0.0158	50ksi	0.150	0.511	0.356	0.199	1.540	0.149	0.996	0.021	0.135	0.035	1051	0.012	0.334	-2.191	2.858	0.412
350PT300-18	0.0188	50ksi	0.179	0.608	0.424	0.237	1.541	0.177	0.995	0.029	0.183	0.048	1427	0.021	0.397	-2.190	2.857	0.412
350PT300-22	0.0232	50ksi	0.220	0.750	0.524	0.292	1.543	0.218	0.994	0.043	0.265	0.070	2095	0.040	0.490	-2.187	2.855	0.413
350PT300-26	0.0274	50ksi	0.260	0.885	0.620	0.345	1.544	0.257	0.994	0.059	0.355	0.096	2871	0.065	0.580	-2.185	2.854	0.414
350PT300-30	0.0312	33ksi	0.296	1.008	0.707	0.393	1.546	0.292	0.993	0.089	0.432	0.149	2945	0.096	0.661	-2.182	2.853	0.415
350PT300-33	0.0346	33ksi	0.328	1.117	0.786	0.435	1.547	0.323	0.992	0.108	0.490	0.183	3615	0.131	0.733	-2.180	2.852	0.415
362PT300-15	0.0158	50ksi	0.152	0.517	0.384	0.208	1.589	0.151	0.995	0.021	0.145	0.036	1090	0.013	0.361	-2.172	2.869	0.427
362PT300-18	0.0188	50ksi	0.181	0.616	0.457	0.247	1.590	0.179	0.994	0.029	0.197	0.050	1481	0.021	0.430	-2.170	2.868	0.427
362PT300-22	0.0232	50ksi	0.223	0.760	0.566	0.305	1.592	0.220	0.994	0.043	0.286	0.073	2177	0.040	0.532	-2.167	2.867	0.429
362PT300-26	0.0274	50ksi	0.264	0.897	0.668	0.359	1.593	0.260	0.993	0.059	0.382	0.100	2979	0.066	0.627	-2.165	2.865	0.429
362PT300-30	0.0312	33ksi	0.300	1.021	0.762	0.409	1.594	0.295	0.992	0.089	0.470	0.155	3056	0.097	0.714	-2.163	2.864	0.430
362PT300-33	0.0346	33ksi	0.333	1.132	0.846	0.453	1.595	0.327	0.992	0.109	0.532	0.190	3751	0.133	0.793	-2.161	2.863	0.430
400PT300-15 ¹	0.0158	50ksi	0.158	0.538	0.474	0.233	1.732	0.155	0.992	0.021	0.178	0.040	1204	0.013	0.450	-2.116	2.909	0.471
400PT300-18	0.0188	50ksi	0.188	0.640	0.565	0.277	1.733	0.185	0.991	0.029	0.242	0.055	1642	0.022	0.536	-2.114	2.908	0.471
400PT300-22	0.0232	50ksi	0.232	0.789	0.698	0.342	1.735	0.228	0.991	0.043	0.349	0.081	2414	0.042	0.662	-2.112	2.907	0.472
400PT300-26	0.0274	50ksi	0.274	0.932	0.825	0.403	1.736	0.268	0.990	0.059	0.467	0.110	3306	0.069	0.782	-2.109	2.906	0.473
400PT300-30	0.0312	33ksi	0.312	1.061	0.941	0.459	1.737	0.305	0.989	0.090	0.593	0.171	3387	0.101	0.891	-2.107	2.905	0.474
400PT300-33	0.0346	33ksi	0.346	1.176	1.045	0.508	1.738	0.338	0.989	0.109	0.671	0.210	4158	0.138	0.988	-2.105	2.904	0.474
550PT300-15 ²	0.0158	50ksi	0.182	0.618	0.951	0.341	2.287	0.172	0.973	0.021	0.338	0.056	1664	0.015	0.930	-1.921	3.142	0.626
550PT300-18 ²	0.0188	50ksi	0.216	0.736	1.132	0.406	2.288	0.204	0.972	0.029	0.468	0.077	2291	0.025	1.107	-1.920	3.141	0.627
550PT300-22 ¹	0.0232	50ksi	0.267	0.908	1.398	0.500	2.290	0.252	0.972	0.043	0.674	0.113	3371	0.048	1.366	-1.917	3.140	0.627
550PT300-26	0.0274	50ksi	0.315	1.072	1.653	0.591	2.291	0.297	0.971	0.060	0.897	0.154	4617	0.079	1.613	-1.915	3.140	0.628
550PT300-30	0.0312	33ksi	0.359	1.220	1.883	0.672	2.292	0.337	0.970	0.092	1.278	0.238	4710	0.116	1.836	-1.913	3.139	0.629
550PT300-33	0.0346	33ksi	0.398	1.353	2.090	0.745	2.293	0.374	0.969	0.111	1.440	0.292	5767	0.159	2.036	-1.911	3.139	0.629
600PT300-15 ²	0.0158	50ksi	0.190	0.645	1.153	0.380	2.467	0.177	0.965	0.021	0.412	0.061	1818	0.016	1.136	-1.865	3.239	0.669
600PT300-18 ²	0.0188	50ksi	0.226	0.768	1.373	0.452	2.468	0.210	0.965	0.029	0.561	0.084	2507	0.027	1.352	-1.863	3.239	0.669
600PT300-22 ¹	0.0232	50ksi	0.278	0.947	1.696	0.557	2.469	0.258	0.964	0.044	0.807	0.123	3691	0.050	1.667	-1.861	3.238	0.670
600PT300-26 ¹	0.0274	50ksi	0.329	1.118	2.005	0.658	2.470	0.305	0.963	0.060	1.073	0.169	5056	0.082	1.969	-1.859	3.238	0.670
600PT300-30	0.0312	33ksi	0.374	1.273	2.285	0.749	2.471	0.346	0.962	0.092	1.580	0.261	5152	0.121	2.241	-1.857	3.237	0.671
600PT300-33	0.0346	33ksi	0.415	1.412	2.535	0.830	2.472	0.384	0.962	0.112	1.780	0.319	6303	0.166	2.485	-1.855	3.237	0.671

¹ Web-height to thickness ratio exceeds 200. Web Stiffeners are required at all support points and concentrated loads.

² Web-depth to thickness ratio exceeds 260. Web stiffeners are required at all bearing and intermediate locations, and no web holes are permitted in non-composite conditions

Which limiting height table?

Composite Assemblies

Composite limiting height data can be applied to walls where gypsum board is installed on both flanges of the stud for the full height of the wall. ProSTUD composite data is based on 2003, 2006, and 2009 International Building Code and was tested and analyzed in accordance with the most recent version of AC86 (2010). In addition, ProSTUD was tested with 1/2" and 5/8" generic gypsum and also 5/8" Type X Gypsum allowing users to apply the specific provided data when different performances are applicable.



*Composite
Gypsum Board
full height on both sides*

Non-Composite Assemblies

Non-Composite conditions are common in all structures. These assemblies occur when the gypsum board stops at the ceiling level, but the stud continues to the deck. The pictures below show some variations of braced non-composite walls.

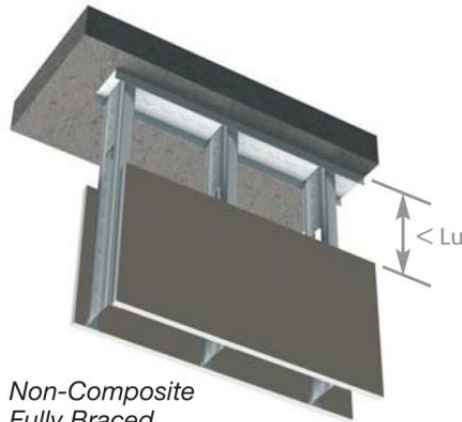

*Non-Composite
Fully Braced
Unbraced length is less than Lu*

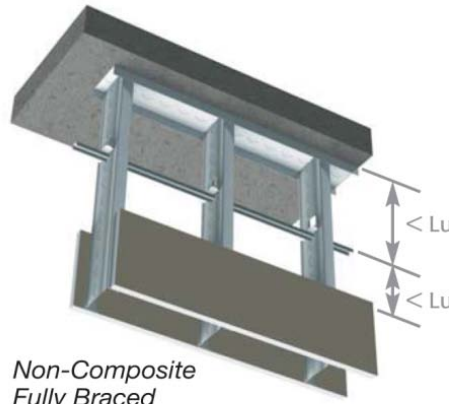

*Non-Composite
Fully Braced
Bracing spacing above gypsum
is less than Lu*

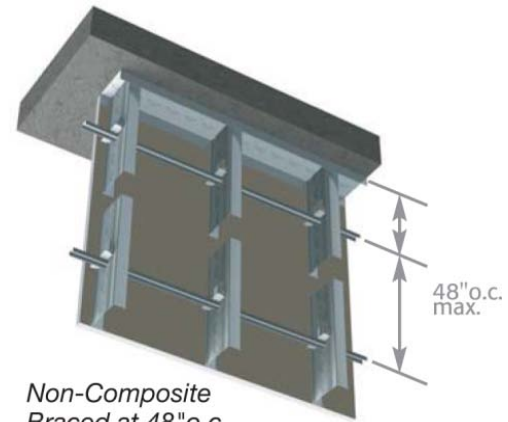

*Non-Composite
Braced at 48"o.c.*

Other Assemblies

For assemblies not listed above, the conditions may vary greatly depending on the building requirements. While the provided non-composite tables may be used conservatively, please consult an architecture before performing any work.

Limiting Wall Heights

Interior Non-Structural Composite Table Notes

1. Allowable composite limiting heights are calculated using ICC-ES AC86-2010. In accordance with current building codes and AISI design standards, the 1/3 Stress Increase for strength was not used.
2. The composite limiting heights provided in the tables are based on a single layer of gypsum board complying with ASTM C1396.
3. The gypsum board must be applied full height in the vertical orientation to each stud flange and installed using minimum No. 6 Type S Drywall screws spaced a minimum of 12-in on-center to the framing members.
4. No fasteners are required for attaching the stud to the track except as detailed in ASTM C754.
5. Stud end bearing must be a minimum of 1 inch.
6. Material yield strength equals 70 ksi for 15Mil and 18Mil studs, 65 ksi for 22Mil and 26Mil studs, and 33 ksi for 30Mil and 33Mil studs
7. ‘f’ adjacent to the height value indicates that flexural stress controls the allowable wall height.
8. ‘s’ adjacent to the height value indicates that shear/end reaction controls the allowable wall height.

Interior Composite data with 1 layer 1/2" Generic Gypsum Board (all brands & types)

Section	Spacing (in) o.c.	5 psf			7.5 psf			10 psf			15 psf		
		L/120	L/240	L/360	L/120	L/240	L/360	L/120	L/240	L/360	L/120	L/240	L/360
162PS125-15	12	12' - 0"	9' - 5"	7' - 11"	10' - 6"	7' - 11"		9' - 5"					
162PS125-15	16	10' - 11"	8' - 4"		9' - 5"			8' - 4" f					
162PS125-15	24	9' - 5"			7' - 10" f								
162PS125-22	12	12' - 11"	10' - 3"	8' - 10"	11' - 3"	8' - 10"		10' - 3"	7' - 10"			8' - 4" f	
162PS125-22	16	11' - 9"	9' - 3"	7' - 10"	10' - 3"	7' - 10"		9' - 3"					
162PS125-22	24	10' - 3"	7' - 10"		8' - 10"			7' - 10"					
250PS125-15	12	14' - 11"	11' - 10"	10' - 4"	13' - 0" f	10' - 4"	8' - 8"	11' - 3" f	9' - 2"				
250PS125-15	16	13' - 7"	10' - 9"	9' - 2"	11' - 3" f	9' - 2"		9' - 9" f	7' - 11"				
250PS125-15	24	11' - 3" f	9' - 2"		9' - 2" f			8' - 0" f					
250PS125-22	12	16' - 10"	13' - 4"	11' - 8"	14' - 8"	11' - 8"	10' - 2"	13' - 4"	10' - 7"	9' - 1"		10' - 3" f	9' - 1"
250PS125-22	16	15' - 3"	12' - 1"	10' - 7"	13' - 4"	10' - 7"	9' - 1"	12' - 1"	9' - 7"	8' - 0"		8' - 10" f	8' - 0"
250PS125-22	24	13' - 4"	10' - 7"	9' - 1"	11' - 8"	9' - 1"		10' - 7"	8' - 0"				
350PS125-15	12	18' - 3"	14' - 6"	12' - 8"	15' - 3" f	12' - 8"	11' - 1"	13' - 3" f	11' - 6"	10' - 1"		8' - 7" f	8' - 7" f 8' - 7" f
350PS125-15	16	16' - 3" f	13' - 2"	11' - 6"	13' - 3" f	11' - 6"	10' - 1"	11' - 6" f	10' - 5"	9' - 1"			
350PS125-15	24	13' - 3" f	11' - 6"	10' - 1"	10' - 10" f	10' - 1"	8' - 9"	9' - 4" f	9' - 1"				
350PS125-22	12	21' - 5"	17' - 0"	14' - 10"	18' - 9"	14' - 10"	13' - 0"	17' - 0"	13' - 6"	11' - 9"		11' - 11" f	11' - 9" 10' - 2"
350PS125-22	16	19' - 6"	15' - 5"	13' - 6"	17' - 0"	13' - 6"	11' - 9"	15' - 5"	12' - 3"	10' - 8"		10' - 4" f	10' - 4" 9' - 3"
350PS125-22	24	17' - 0"	13' - 6"	11' - 9"	14' - 9" f	11' - 9"	10' - 2"	12' - 10" f	10' - 8"	9' - 3"			
362PS125-15	12	18' - 7"	14' - 9"	12' - 10"	15' - 3" f	12' - 10"	11' - 3"	13' - 3" f	11' - 8"	10' - 2"		8' - 7" f	8' - 7" f 8' - 7" f
362PS125-15	16	16' - 2" f	13' - 5"	11' - 8"	13' - 3" f	11' - 8"	10' - 2"	11' - 5" f	10' - 7"	9' - 2"			
362PS125-15	24	13' - 3" f	11' - 8"	10' - 2"	10' - 9" f	10' - 2"	8' - 10"	9' - 4" f	9' - 2"	8' - 0"			
362PS125-22	12	21' - 8"	17' - 3"	15' - 1"	19' - 0"	15' - 1"	13' - 2"	17' - 3"	13' - 8"	11' - 11"		12' - 5" f	11' - 11" 10' - 5"
362PS125-22	16	19' - 9"	15' - 8"	13' - 8"	17' - 3" f	13' - 8"	11' - 11"	15' - 8"	12' - 5"	10' - 10"		10' - 9" f	10' - 9" f
362PS125-22	24	17' - 3"	13' - 8"	11' - 11"	15' - 1"	11' - 11"	10' - 5"	13' - 4" f	10' - 10"				
400PS125-15	12	19' - 11" f	15' - 11"	13' - 10"	16' - 3" f	13' - 10"	12' - 1"	14' - 1" f	12' - 7"	11' - 0"		9' - 2" f	9' - 2" 9' - 2"
400PS125-15	16	17' - 3" f	14' - 5"	12' - 7"	14' - 1" f	12' - 7"	11' - 0"	12' - 2" f	11' - 5"	10' - 0"			
400PS125-15	24	14' - 1" f	12' - 7"	11' - 0"	11' - 6" f	11' - 0"	9' - 7"	10' - 0" f	10' - 0" f	8' - 8"			
400PS125-22	12	23' - 5"	18' - 7"	16' - 3"	20' - 5"	16' - 3"	14' - 2"	18' - 7"	14' - 9"	12' - 11"		12' - 8" f	12' - 8" f 11' - 2"
400PS125-22	16	21' - 3"	16' - 11"	14' - 9"	18' - 7"	14' - 9"	12' - 11"	16' - 8" f	13' - 5"	11' - 8"		10' - 11" f	10' - 11" f 10' - 1"
400PS125-22	24	18' - 7"	14' - 9"	12' - 11"	15' - 8"	12' - 11"	11' - 2"	13' - 7" f	11' - 8"	10' - 3"			
550PS125-15	12	23' - 2" f	19' - 8"	17' - 2"	18' - 11" f	17' - 2"	15' - 0"	16' - 5" f	15' - 7"	13' - 7"		10' - 8" f	10' - 8" f 10' - 8" f
550PS125-15	16	20' - 1" f	17' - 10"	15' - 7"	16' - 5" f	15' - 7"	13' - 7"	14' - 2" f	14' - 2"	12' - 5"			
550PS125-15	24	16' - 5" f	15' - 7"	13' - 7"	13' - 5" f	13' - 5" f	11' - 11"	11' - 7" f	11' - 7" f	10' - 10"			
550PS125-22	12	28' - 9"	22' - 10"	19' - 11"	25' - 1"	19' - 11"	17' - 5"	22' - 3" f	18' - 1"	15' - 10"		14' - 8" f	14' - 8" f 13' - 10"
550PS125-22	16	26' - 1"	20' - 9"	18' - 1"	22' - 3" f	18' - 1"	15' - 10"	19' - 4" f	16' - 5"	14' - 4"		12' - 8" f	12' - 8" f 12' - 6"
550PS125-22	24	22' - 3" f	18' - 1"	15' - 10"	18' - 2" f	15' - 10"	13' - 10"	15' - 9" f	14' - 4"	12' - 6"		10' - 4" f	10' - 4" f 10' - 4" f
600PS125-15	12	24' - 3" f	20' - 7"	18' - 3"	19' - 10" f	18' - 0"	16' - 0" f	17' - 2" f	16' - 4"	14' - 7"		11' - 3" f	11' - 3" f 11' - 3" f
600PS125-15	16	21' - 0" f	18' - 8"	16' - 8"	17' - 2" f	16' - 4"	14' - 7" f	14' - 10" f	14' - 10"	13' - 3"			
600PS125-15	24	17' - 2" f	16' - 4"	14' - 7"	14' - 0" f	14' - 0" f	12' - 9" f	12' - 2" f	12' - 2" f	11' - 7"			
600PS125-22	12	29' - 8"	24' - 2"	21' - 0"	25' - 11"	21' - 2"	18' - 7" f	23' - 0" f	19' - 2"	16' - 11"		15' - 2" f	15' - 2" f 14' - 11"
600PS125-22	16	27' - 0"	22' - 0"	19' - 3"	23' - 0" f	19' - 2"	16' - 11" f	19' - 11" f	17' - 5"	15' - 6"		13' - 1" f	13' - 1" f 13' - 1" f
600PS125-22	24	23' - 0" f	19' - 2"	16' - 11"	18' - 10" f	16' - 9"	14' - 11" f	16' - 3" f	15' - 3"	13' - 7"		10' - 3" s	10' - 3" s 10' - 3" s

Notes:

1. Generic – As outlined by AC86 Section 3.1.3, the gypsum board is considered generic since the flexural strength test results do not exceed 15 percent above the applicable ASTM standard.

Limiting Wall Heights

Interior Non-Structural Composite Table Notes

1. Allowable composite limiting heights are calculated using ICC-ES AC86-2010. In accordance with current building codes and AISI design standards, the 1/3 Stress Increase for strength was not used.
2. The composite limiting heights provided in the tables are based on a single layer of gypsum board complying with ASTM C1396.
3. The gypsum board must be applied full height in the vertical orientation to each stud flange and installed using minimum No. 6 Type S Drywall screws spaced a minimum of 12-in on-center to the framing members.
4. No fasteners are required for attaching the stud to the track except as detailed in ASTM C754.
5. Stud end bearing must be a minimum of 1 inch.
6. Material yield strength equals 70 ksi for 15Mil and 18Mil studs, 65 ksi for 22Mil and 26Mil studs, and 33 ksi for 30Mil and 33Mil studs
7. ‘f’ adjacent to the height value indicates that flexural stress controls the allowable wall height.
8. ‘s’ adjacent to the height value indicates that shear/end reaction controls the allowable wall height.

Interior Composite data with 1 layer 1/2” Generic Gypsum Board (all brands & types)

Section	Spacing (in) o.c.	5 psf			7.5 psf			10 psf			15 psf		
		L/120	L/240	L/360	L/120	L/240	L/360	L/120	L/240	L/360	L/120	L/240	L/360
162PS125-26	12	13'-5"	10' - 7"	9' - 2"	11' - 8"	9' - 2"	7' - 10"	10' - 7"	8' - 2"		9' - 2"		
162PS125-26	16	12'-2"	9' - 7"	8' - 2"	10' - 7"	8' - 2"		9' - 7"			8' - 2"		
162PS125-26	24	10' - 7"	8' - 2"		9' - 2"			8' - 2"					
162PS125-33	12	14' - 2"	11' - 3"	9' - 10"	12' - 5"	9' - 10"	8' - 6"	11' - 3"	8' - 10"		10' - 9"		
162PS125-33	16	12' - 11"	10' - 3"	8' - 10"	11' - 3"	8' - 10"		10' - 3"	8' - 0"		8' - 7" f		
162PS125-33	24	11' - 3"	8' - 10"		9' - 10"			8' - 10"					
250PS125-26	12	17' - 1"	14' - 0"	12' - 3"	14' - 11"	12' - 3"	10' - 8"	13' - 7"	11' - 1"	9' - 8"	11' - 7" f	9' - 8"	8' - 2"
250PS125-26	16	15' - 6"	12' - 8"	11' - 1"	13' - 7"	11' - 1"	9' - 8"	12' - 4"	10' - 1"	8' - 7"	10' - 0" f	8' - 7"	
250PS125-26	24	13' - 7"	11' - 1"	9' - 8"	11' - 10"	9' - 8"	8' - 2"	10' - 9"	8' - 7"		8' - 2" f		
250PS125-33	12	18' - 6"	14' - 8"	12' - 10"	16' - 2"	12' - 10"	11' - 3"	14' - 8"	11' - 8"	10' - 2"	12' - 4" f	10' - 2"	8' - 9"
250PS125-33	16	16' - 10"	13' - 4"	11' - 8"	14' - 8"	11' - 8"	10' - 2"	13' - 4"	10' - 7"	9' - 2"	10' - 8" f	9' - 2"	7' - 10"
250PS125-33	24	14' - 8"	11' - 8"	10' - 2"	12' - 10"	10' - 2"	8' - 9"	11' - 8"	9' - 2"	7' - 10"	8' - 8" f	7' - 10"	
350PS125-26	12	22' - 4"	17' - 9"	15' - 6"	19' - 6"	15' - 6"	13' - 7"	17' - 9"	14' - 1"	12' - 4"	13' - 7" f	12' - 4"	10' - 9"
350PS125-26	16	20' - 4"	16' - 2"	14' - 1"	17' - 9"	14' - 1"	12' - 4"	16' - 2"	12' - 10"	11' - 2"	11' - 9" f	11' - 2"	9' - 9"
350PS125-26	24	17' - 9"	14' - 1"	12' - 4"	15' - 6"	12' - 4"	10' - 9"	14' - 1"	11' - 2"	9' - 9"	9' - 7" f	9' - 7" f	
350PS125-33	12	24' - 2"	19' - 2"	16' - 9"	21' - 2"	16' - 9"	14' - 8"	19' - 2"	15' - 3"	13' - 4"	14' - 9" f	13' - 4"	11' - 7"
350PS125-33	16	22' - 0"	17' - 5"	15' - 3"	19' - 2"	15' - 3"	13' - 4"	17' - 5"	13' - 10"	12' - 1"	12' - 9" f	12' - 1"	10' - 6"
350PS125-33	24	19' - 2"	15' - 3"	13' - 4"	16' - 9"	13' - 4"	11' - 7"	15' - 3"	12' - 1"	10' - 6"	10' - 5" f	10' - 5" f	9' - 2"
362PS125-26	12	22' - 7"	17' - 11"	15' - 8"	19' - 9"	15' - 8"	13' - 8"	17' - 11"	14' - 3"	12' - 5"	13' - 11" f	12' - 5"	10' - 10"
362PS125-26	16	20' - 6"	16' - 4"	14' - 3"	17' - 11"	14' - 3"	12' - 5"	16' - 4"	12' - 11"	11' - 3"	12' - 1" f	11' - 3"	9' - 10"
362PS125-26	24	17' - 11"	14' - 3"	12' - 5"	15' - 8"	12' - 5"	10' - 10"	14' - 3"	11' - 3"	9' - 10"	9' - 10" f	9' - 10" f	
362PS125-33	12	24' - 4"	19' - 4"	16' - 10"	21' - 3"	16' - 10"	14' - 9"	19' - 4"	15' - 4"	13' - 5"	15' - 5" f	13' - 5"	11' - 8"
362PS125-33	16	22' - 1"	17' - 7"	15' - 4"	19' - 4"	15' - 4"	13' - 5"	17' - 7"	13' - 11"	12' - 2"	13' - 4" f	12' - 2"	10' - 6"
362PS125-33	24	19' - 4"	15' - 4"	13' - 5"	16' - 10"	13' - 5"	11' - 8"	15' - 4"	12' - 2"	10' - 6"	10' - 11" f	10' - 6"	
400PS125-26	12	24' - 6"	19' - 5"	17' - 0"	21' - 5"	17' - 0"	14' - 10"	19' - 5"	15' - 5"	13' - 6"	14' - 5" f	13' - 6"	11' - 9"
400PS125-26	16	22' - 3"	17' - 8"	15' - 5"	19' - 5"	15' - 5"	13' - 6"	17' - 8"	14' - 0"	12' - 3"	12' - 6" f	12' - 3"	10' - 8"
400PS125-26	24	19' - 5"	15' - 5"	13' - 6"	17' - 0"	13' - 6"	11' - 9"	15' - 5"	12' - 3"	10' - 8"	10' - 3" f	10' - 3" f	
400PS125-33	12	26' - 7"	21' - 1"	18' - 5"	23' - 3"	18' - 5"	16' - 1"	21' - 1"	16' - 9"	14' - 8"	15' - 9" f	14' - 8"	12' - 9"
400PS125-33	16	24' - 2"	19' - 2"	16' - 9"	21' - 1"	16' - 9"	14' - 8"	19' - 2"	15' - 3"	13' - 4"	13' - 7" f	13' - 4"	11' - 7"
400PS125-33	24	21' - 1"	16' - 9"	14' - 8"	18' - 5"	14' - 8"	12' - 9"	16' - 9"	13' - 4"	11' - 7"	11' - 1" f	11' - 1" f	10' - 1"
550PS125-26	12	29' - 4"	23' - 6"	20' - 8"	25' - 10"	20' - 8"	18' - 2"	23' - 6"	18' - 10"	16' - 6"	16' - 10" f	16' - 6"	14' - 6"
550PS125-26	16	26' - 9"	21' - 6"	18' - 10"	23' - 6"	18' - 10"	16' - 6"	21' - 6"	17' - 2"	15' - 1"	14' - 7" f	14' - 7" f	13' - 2"
550PS125-26	24	23' - 6"	18' - 10"	16' - 6"	20' - 8"	16' - 6"	14' - 6"	18' - 1" f	15' - 1"	13' - 2"	11' - 11" f	11' - 11" f	11' - 6"
550PS125-33	12	32' - 8"	26' - 0"	22' - 9"	28' - 7"	22' - 9"	19' - 11"	26' - 0"	20' - 8"	18' - 1"	18' - 5" f	18' - 1"	15' - 10"
550PS125-33	16	29' - 8"	23' - 8"	20' - 8"	26' - 0"	20' - 8"	18' - 1"	23' - 8"	18' - 10"	16' - 6"	15' - 11" f	15' - 11" f	14' - 5"
550PS125-33	24	26' - 0"	20' - 8"	18' - 1"	22' - 9"	18' - 1"	15' - 10"	19' - 10" f	16' - 6"	14' - 5"	12' - 7" s	12' - 7" s	12' - 7" s
600PS125-26	12	30' - 9"	24' - 9"	21' - 9"	27' - 1"	21' - 9"	19' - 2"	24' - 9"	19' - 10"	17' - 5"	17' - 6" f	17' - 5"	15' - 4"
600PS125-26	16	28' - 2"	22' - 7"	19' - 10"	24' - 9"	19' - 10"	17' - 5"	22' - 7"	18' - 2"	15' - 11"	15' - 2" f	15' - 2" f	13' - 11"
600PS125-26	24	24' - 9"	19' - 10"	17' - 5"	21' - 9" f	17' - 5"	15' - 4"	18' - 10" f	15' - 11"	13' - 11"	12' - 4" f	12' - 4" f	12' - 2"
600PS125-33	12	34' - 2"	27' - 4"	24' - 0"	30' - 0"	24' - 0"	21' - 0"	27' - 4"	21' - 10"	19' - 2"	19' - 1" f	19' - 1" f	16' - 9"
600PS125-33	16	31' - 2"	24' - 11"	21' - 10"	27' - 4"	21' - 10"	19' - 2"	24' - 11"	19' - 11"	17' - 5"	16' - 6" f	16' - 6" f	15' - 3"
600PS125-33	24	27' - 4"	21' - 10"	19' - 2"	23' - 9" f	19' - 2"	16' - 9"	20' - 6" f	17' - 5"	15' - 3"	12' - 4" s	12' - 4" s	12' - 4" s

Notes:

1. Generic – As outlined by AC86 Section 3.1.3, the gypsum board is considered generic since the flexural strength test results do not exceed 15 percent above the applicable ASTM standard.

Limiting Wall Heights

Interior Non-Structural Composite Table Notes

1. Allowable composite limiting heights are calculated using ICC-ES AC86-2010. In accordance with current building codes and AISI design standards, the 1/3 Stress Increase for strength was not used.
2. The composite limiting heights provided in the tables are based on a single layer of gypsum board complying with ASTM C1396.
3. The gypsum board must be applied full height in the vertical orientation to each stud flange and installed using minimum No. 6 Type S Drywall screws spaced a minimum of 12-in on-center to the framing members.
4. No fasteners are required for attaching the stud to the track except as detailed in ASTM C754.
5. Stud end bearing must be a minimum of 1 inch.
6. Material yield strength equals 70 ksi for 15Mil and 18Mil studs, 65 ksi for 22Mil and 26Mil studs, and 33 ksi for 30Mil and 33Mil studs
7. ‘f’ adjacent to the height value indicates that flexural stress controls the allowable wall height.
8. ‘s’ adjacent to the height value indicates that shear/end reaction controls the allowable wall height.

Interior Composite data with 1 layer 5/8” Generic Gypsum Board (all brands & types)

Section	Spacing (in) o.c.	5 psf			7.5 psf			10 psf			15 psf		
		L/120	L/240	L/360	L/120	L/240	L/360	L/120	L/240	L/360	L/120	L/240	L/360
162PS125-15	12	12'-6"	9'-11"	8'-6"	10'-11"	8'-6"		9'-11"			8'-5" f		
162PS125-15	16	11'-5"	8'-11"		9'-11"			8'-11"					
162PS125-15	24	9'-11"			8'-6"								
162PS125-22	12	13'-2"	10'-5"	9'-1"	11'-6"	9'-1"	7'-10"	10'-5"	8'-2"		8'-11" f		
162PS125-22	16	12'-0"	9'-6"	8'-2"	10'-5"	8'-2"		9'-6"			7'-9" f		
162PS125-22	24	10'-5"	8'-2"		9'-1"			8'-2"					
250PS125-15	12	15'-3"	12'-7"	11'-1"	13'-4"	11'-0"	9'-8"	12'-1"	10'-0"	8'-9"	8'-8" f	8'-7"	
250PS125-15	16	13'-10"	11'-5"	10'-1"	12'-1"	10'-0"	8'-9"	11'-0"	8'-11"	7'-10"			
250PS125-15	24	12'-1"	10'-0"	8'-9"	10'-7"	8'-7"		9'-4" f					
250PS125-22	12	16'-10"	13'-5"	11'-8"	14'-9"	11'-8"	10'-3"	13'-5"	9'-3"	10'-8"	10'-6" f	9'-3"	7'-11"
250PS125-22	16	15'-4"	12'-2"	10'-8"	13'-5"	10'-8"	9'-3"	12'-2"	8'-3"	9'-8"	9'-1" f	8'-3"	
250PS125-22	24	13'-5"	10'-8"	9'-3"	11'-8"	9'-3"	7'-11"	10'-8"		8'-3"			
350PS125-15	12	18'-8"	14'-10"	13'-0"	16'-4"	13'-0"	11'-4"	14'-4" f	11'-9"	10'-3"	9'-5" f	9'-5" f	8'-11"
350PS125-15	16	17'-0"	13'-6"	11'-9"	14'-4" f	11'-9"	10'-3"	12'-5" f	10'-8"	9'-3"	8'-2" f	8'-2" f	8'-0"
350PS125-15	24	14'-4" f	11'-9"	10'-3"	11'-8" f	10'-3"	8'-11"	10'-1" f	9'-3"	8'-0"			
350PS125-22	12	21'-4"	16'-11"	14'-9"	18'-8"	14'-9"	12'-11"	16'-11"	13'-5"	11'-9"	12'-4" f	11'-9"	10'-2"
350PS125-22	16	19'-5"	15'-5"	13'-5"	16'-11"	13'-5"	11'-9"	15'-5"	12'-3"	10'-7"	10'-8" f	10'-7"	9'-2"
350PS125-22	24	16'-11"	13'-5"	11'-9"	14'-9"	11'-9"	10'-2"	13'-4" f	10'-7"	9'-2"			
362PS125-15	12	19'-1"	15'-1"	13'-2"	16'-7" f	13'-2"	11'-6"	14'-4" f	12'-0"	10'-5"	9'-5" f	9'-5" f	9'-0"
362PS125-15	16	17'-4"	13'-9"	12'-0"	14'-4" f	12'-0"	10'-5"	12'-5" f	10'-10"	9'-4"	8'-2" f	8'-2" f	8'-1"
362PS125-15	24	14'-4" f	12'-0"	10'-5"	11'-9" f	10'-5"	9'-0"	10'-2" f	9'-4"	8'-1"			
362PS125-22	12	21'-10"	17'-4"	15'-2"	19'-1" f	15'-2"	13'-3"	17'-4"	13'-9"	11'-11"	13'-0" f	11'-11"	10'-3"
362PS125-22	16	19'-10"	15'-9"	13'-9"	17'-4"	13'-9"	11'-11"	15'-9"	12'-6"	10'-8"	11'-3" f	10'-8"	
362PS125-22	24	17'-4"	13'-9"	11'-11"	15'-2"	11'-11"	10'-3"	13'-9"	10'-8"				
400PS125-15	12	20'-6"	16'-3"	14'-3"	17'-6" f	14'-3"	12'-5"	15'-2" f	12'-11"	11'-3"	10'-0" f	10'-0" f	9'-9"
400PS125-15	16	18'-7" f	14'-10"	12'-11"	15'-2" f	12'-11"	11'-3"	13'-2" f	11'-9"	10'-2"	8'-8" f	8'-8" f	8'-8" f
400PS125-15	24	15'-2" f	12'-11"	11'-3"	12'-5" f	11'-3"	9'-9"	10'-9" f	10'-2"	8'-9"			
400PS125-22	12	23'-5"	18'-7"	16'-3"	20'-6"	16'-3"	14'-2"	18'-7"	14'-9"	12'-11"	13'-1" f	12'-11"	11'-2"
400PS125-22	16	21'-4"	16'-11"	14'-9"	18'-7"	14'-9"	12'-11"	16'-11"	13'-5"	11'-8"	11'-4" f	11'-4" f	10'-1"
400PS125-22	24	18'-7"	14'-9"	12'-11"	16'-3"	12'-11"	11'-2"	14'-1" f	11'-8"	10'-1"	9'-3" f	9'-3" f	
550PS125-15	12	24'-11" f	19'-11"	17'-4"	20'-4" f	17'-4"	15'-2"	17'-7" f	15'-9"	13'-9"	11'-7" f	11'-7" f	11'-7" f
550PS125-15	16	21'-7" f	18'-1"	15'-9"	17'-7" f	15'-9"	13'-9"	15'-3" f	14'-4"	12'-6"	10'-0" f	10'-0" f	10'-0" f
550PS125-15	24	17'-7" f	15'-9"	13'-9"	14'-4" f	13'-9"	12'-0"	12'-5" f	12'-5" f	10'-10"			
550PS125-22	12	29'-1"	23'-1"	20'-2"	25'-5"	20'-2"	17'-7"	23'-0" f	18'-4"	16'-0"	15'-2" f	15'-2" f	14'-0"
550PS125-22	16	26'-5"	21'-0"	18'-4"	23'-0" f	18'-4"	16'-0"	19'-11" f	16'-8"	14'-6"	13'-1" f	13'-1" f	12'-7"
550PS125-22	24	23'-0" f	18'-4"	16'-0"	18'-10" f	16'-0"	14'-0"	16'-3" f	14'-6"	12'-7"	10'-8" f	10'-8" f	10'-8" f
600PS125-15	12	26'-0" f	20'-11"	18'-7"	21'-3" f	18'-3"	16'-3"	18'-5" f	16'-7"	14'-9"	12'-1" f	12'-1" f	12'-1" f
600PS125-15	16	22'-6" f	19'-0"	16'-10"	18'-5" f	16'-7"	14'-9"	15'-11" f	15'-1"	13'-4"	10'-6" f	10'-6" f	10'-6" f
600PS125-15	24	18'-5" f	16'-7"	14'-9"	15'-0" f	14'-6"	12'-10"	13'-0" f	13'-0" f	11'-7"			
600PS125-22	12	31'-7"	24'-5"	21'-6"	27'-6" f	21'-4"	18'-10"	23'-9" f	19'-5"	17'-1"	15'-8" f	15'-8" f	14'-11"
600PS125-22	16	28'-8"	22'-2"	19'-7"	23'-9" f	19'-5"	17'-1"	20'-7" f	17'-7"	15'-6"	13'-6" f	13'-6" f	13'-6" f
600PS125-22	24	23'-9" f	19'-5"	17'-1"	19'-5" f	16'-11"	14'-11"	16'-10" f	15'-5"	13'-6"	11'-1" f	11'-1" f	11'-1" f

Notes:

1. Generic – As outlined by AC86 Section 3.1.3, the gypsum board is considered generic since the flexural strength test results do not exceed 15 percent above the applicable ASTM standard.

Limiting Wall Heights

Interior Non-Structural Composite Table Notes

1. Allowable composite limiting heights are calculated using ICC-ES AC86-2010. In accordance with current building codes and AISI design standards, the 1/3 Stress Increase for strength was not used.
2. The composite limiting heights provided in the tables are based on a single layer of gypsum board complying with ASTM C1396.
3. The gypsum board must be applied full height in the vertical orientation to each stud flange and installed using minimum No. 6 Type S Drywall screws spaced a minimum of 12-in on-center to the framing members.
4. No fasteners are required for attaching the stud to the track except as detailed in ASTM C754.
5. Stud end bearing must be a minimum of 1 inch.
6. Material yield strength equals 70 ksi for 15Mil and 18Mil studs, 65 ksi for 22Mil and 26Mil studs, and 33 ksi for 30Mil and 33Mil studs
7. ‘f’ adjacent to the height value indicates that flexural stress controls the allowable wall height.
8. ‘s’ adjacent to the height value indicates that shear/end reaction controls the allowable wall height.

Interior Composite data with 1 layer 5/8” Generic Gypsum Board (all brands & types)

Section	Spacing (in) o.c.	5 psf			7.5 psf			10 psf			15 psf		
		L/120	L/240	L/360	L/120	L/240	L/360	L/120	L/240	L/360	L/120	L/240	L/360
162PS125-26	12	13'-9"	10'-11"	9'-6"	12'-0"	9'-6"	8'-1"	10'-11"	8'-6"		9'-6"		
162PS125-26	16	12'-6"	9'-11"	8'-6"	10'-11"	8'-6"		9'-11"			8'-6"		
162PS125-26	24	10'-11"	8'-6"		9'-6"			8'-6"					
162PS125-33	12	14'-6"	11'-6"	10'-1"	12'-8"	10'-1"	8'-8"	11'-6"	9'-1"	7'-10"	10'-1"	7'-10"	
162PS125-33	16	13'-2"	10'-6"	9'-1"	11'-6"	9'-1"	7'-10"	10'-6"	8'-2"		9'-1"		
162PS125-33	24	11'-6"	9'-1"	7'-10"	10'-1"	7'-10"		9'-1"			7'-10" f		
250PS125-26	12	17'-7"	14'-0"	12'-3"	15'-5"	12'-3"	10'-8"	14'-0"	11'-1"	9'-8"	11'-8" f	9'-8"	8'-3"
250PS125-26	16	16'-0"	12'-8"	11'-1"	14'-0"	11'-1"	9'-8"	12'-8"	10'-1"	8'-8"	10'-1" f	8'-8"	
250PS125-26	24	14'-0"	11'-1"	9'-8"	12'-3"	9'-8"	8'-3"	11'-1"	8'-8"		8'-3" f		
250PS125-33	12	19'-0"	15'-1"	13'-2"	16'-7"	13'-2"	11'-6"	15'-1"	12'-0"	10'-5"	13'-1" f	10'-5"	9'-0"
250PS125-33	16	17'-3"	13'-8"	12'-0"	15'-1"	12'-0"	10'-5"	13'-8"	10'-10"	9'-5"	11'-4" f	9'-5"	8'-0"
250PS125-33	24	15'-1"	12'-0"	10'-5"	13'-2"	10'-5"	9'-0"	12'-0"	9'-5"	8'-0"	9'-3" f	8'-0"	
350PS125-26	12	22'-2"	17'-7"	15'-4"	19'-4"	15'-4"	15'-4"	17'-7"	13'-11"	12'-2"	14'-0" f	12'-2"	10'-7"
350PS125-26	16	20'-2"	16'-0"	13'-11"	17'-7"	13'-11"	13'-11"	16'-0"	12'-8"	11'-1"	12'-2" f	11'-1"	9'-7"
350PS125-26	24	17'-7"	13'-11"	12'-2"	15'-4"	12'-2"	12'-2"	13'-11"	11'-1"	9'-7"	9'-11" f	9'-7"	
350PS125-33	12	23'-9"	18'-10"	16'-6"	20'-9"	16'-6"	14'-5"	18'-10"	15'-0"	13'-1"	15'-6" f	13'-1"	11'-4"
350PS125-33	16	21'-7"	17'-2"	15'-0"	18'-10"	15'-0"	13'-1"	17'-2"	13'-7"	11'-10"	13'-5" f	11'-10"	10'-2"
350PS125-33	24	18'-10"	15'-0"	13'-1"	16'-6"	13'-1"	11'-4"	15'-0"	11'-10"	10'-2"	10'-11" f	10'-2"	
362PS125-26	12	22'-6"	17'-10"	15'-7"	19'-8"	15'-7"	13'-7"	17'-10"	14'-2"	12'-4"	14'-4" f	12'-4"	10'-8"
362PS125-26	16	20'-5"	16'-3"	14'-2"	17'-10"	14'-2"	12'-4"	16'-3"	12'-10"	11'-1"	12'-5" f	11'-1"	
362PS125-26	24	17'-10"	14'-2"	12'-4"	15'-7"	12'-4"	10'-8"	14'-2"	11'-1"		10'-2" f		
362PS125-33	12	24'-3"	19'-3"	16'-10"	21'-2"	16'-10"	14'-8"	19'-3"	15'-3"	13'-4"	16'-4" f	13'-4"	11'-7"
362PS125-33	16	22'-0"	17'-6"	15'-3"	19'-3"	15'-3"	13'-4"	17'-6"	13'-11"	12'-1"	14'-2" f	12'-1"	10'-5"
362PS125-33	24	19'-3"	15'-3"	13'-4"	16'-10"	13'-4"	11'-7"	15'-3"	12'-1"	10'-5"	11'-7" f	10'-5"	
400PS125-26	12	24'-8"	19'-7"	17'-1"	21'-6"	17'-1"	14'-11"	19'-7"	15'-6"	13'-7"	14'-11" f	13'-7"	11'-9"
400PS125-26	16	22'-4"	17'-9"	15'-6"	19'-7"	15'-6"	13'-7"	17'-9"	14'-1"	12'-3"	12'-11" f	12'-3"	10'-8"
400PS125-26	24	19'-7"	15'-6"	13'-7"	17'-1"	13'-7"	11'-9"	15'-6"	12'-3"	10'-8"	10'-7" f	10'-7" f	
400PS125-33	12	26'-7"	21'-1"	18'-5"	23'-3"	18'-5"	16'-1"	21'-1"	16'-9"	14'-8"	16'-5" f	14'-8"	12'-9"
400PS125-33	16	24'-2"	19'-2"	16'-9"	21'-1"	16'-9"	14'-8"	19'-2"	15'-3"	13'-3"	14'-3" f	13'-3"	11'-6"
400PS125-33	24	21'-1"	16'-9"	14'-8"	18'-5"	14'-8"	12'-9"	16'-9"	13'-3"	11'-6"	11'-7" f	11'-6"	
550PS125-26	12	30'-5"	24'-2"	21'-1"	26'-7"	21'-1"	18'-5"	24'-2"	19'-2"	16'-9"	17'-5" f	16'-9"	14'-8"
550PS125-26	16	27'-8"	21'-11"	19'-2"	24'-2"	19'-2"	16'-9"	21'-11"	17'-5"	15'-3"	15'-1" f	15'-1" f	13'-3"
550PS125-26	24	24'-2"	19'-2"	16'-9"	21'-1"	16'-9"	14'-8"	18'-9" f	15'-3"	13'-3"	12'-4" f	12'-4" f	11'-6"
550PS125-33	12	32'-10"	26'-1"	22'-9"	28'-8"	22'-9"	19'-11"	26'-1"	20'-8"	18'-1"	19'-0" f	18'-1"	15'-10"
550PS125-33	16	29'-10"	23'-8"	20'-8"	26'-1"	20'-8"	18'-1"	23'-8"	18'-10"	16'-5"	16'-5" f	16'-5"	14'-4"
550PS125-33	24	26'-1"	20'-8"	18'-1"	22'-9"	18'-1"	15'-10"	20'-5" f	16'-5"	14'-4"	13'-5" f	13'-5" f	12'-6"
600PS125-26	12	32'-5"	25'-9"	22'-6"	28'-4"	22'-6"	19'-8"	25'-9"	20'-5"	17'-10"	18'-2" f	17'-10"	15'-7"
600PS125-26	16	29'-5"	23'-5"	20'-5"	25'-9"	20'-5"	17'-10"	23'-5"	18'-7"	16'-3"	15'-9" f	15'-9" f	14'-1"
600PS125-26	24	25'-9"	20'-5"	17'-10"	22'-6"	17'-10"	15'-7"	19'-7" f	16'-3"	14'-1"	12'-10" f	12'-10" f	12'-3"
600PS125-33	12	34'-11"	27'-9"	24'-3"	30'-6"	24'-3"	21'-2"	27'-9"	22'-0"	19'-3"	19'-7" f	19'-3"	16'-10"
600PS125-33	16	31'-9"	25'-2"	22'-0"	27'-9"	22'-0"	19'-3"	25'-2"	20'-0"	17'-6"	17'-0" f	17'-0" f	15'-3"
600PS125-33	24	27'-9"	22'-0"	19'-3"	24'-3"	19'-3"	16'-10"	21'-1" f	17'-6"	15'-3"	13'-10" f	13'-10" f	13'-3"

Notes:

1. Generic – As outlined by AC86 Section 3.1.3, the gypsum board is considered generic since the flexural strength test results do not exceed 15 percent above the applicable ASTM standard.

Limiting Wall Heights

Interior Non-Structural Composite Table Notes

1. Allowable composite limiting heights are calculated using ICC-ES AC86-2010. In accordance with current building codes and AISI design standards, the 1/3 Stress Increase for strength was not used.
2. The composite limiting heights provided in the table are based on a single layer of 5/8" thick Type X USG Gypsum board complying with ASTM C1396.
3. The gypsum board must be applied full height in the vertical orientation to each stud flange and installed using minimum No. 6 Type S Drywall screws spaced a minimum of 12-in on-center to the framing members.
4. No fasteners are required for attaching the stud to the track except as detailed in ASTM C754.
5. Stud end bearing must be a minimum of 1 inch.
6. Material yield strength equals 70 ksi for 15Mil and 18Mil studs, 65 ksi for 22Mil and 26Mil studs, and 33 ksi for 30Mil and 33Mil studs
7. 'f' adjacent to the height value indicates that flexural stress controls the allowable wall height.
8. 's' adjacent to the height value indicates that shear/end reaction controls the allowable wall height.

Interior Composite data with 1 layer 5/8" Type X Gypsum Board

Section	Spacing (in) o.c.	5 psf			7.5 psf			10 psf			15 psf		
		L/120	L/240	L/360	L/120	L/240	L/360	L/120	L/240	L/360	L/120	L/240	L/360
162PS125-15	12	14'-4"	11'-4"	9'-11"	12'-6"	9'-11"	8'-5"	11'-4"	8'-10"		8'-2" f		
162PS125-15	16	13'-0"	10'-4"	8'-10"	11'-4"	8'-10"		10'-4"	7'-10"				
162PS125-15	24	11'-4"	8'-10"		9'-11"			8'-9" f					
162PS125-22	12	14'-9"	11'-8"	10'-3"	12'-10"	10'-3"	8'-9"	11'-8"	9'-2"		10'-0" f		
162PS125-22	16	13'-5"	10'-7"	9'-2"	11'-8"	9'-2"		10'-7"	8'-1"		8'-8" f		
162PS125-22	24	11'-8"	9'-2"		10'-3"			9'-2"					
250PS125-15	12	17'-2"	13'-7"	11'-11"	15'-0"	11'-11"	10'-5"	13'-6" f	10'-10"	9'-4"	8'-10" f	8'-10" f	
250PS125-15	16	15'-7"	12'-4"	10'-10"	13'-6" f	10'-10"	9'-4"	11'-8" f	9'-10"	8'-2"			
250PS125-15	24	13'-6" f	10'-10"	9'-4"	11'-0" f	9'-4"		9'-6" f	8'-2"				
250PS125-22	12	18'-5"	14'-8"	12'-9"	16'-1"	12'-9"	11'-2"	14'-8"	11'-7"	10'-2"	11'-6" f	10'-2"	8'-7"
250PS125-22	16	16'-9"	13'-4"	11'-7"	14'-8"	11'-7"	10'-2"	13'-4"	10'-7"	9'-0"	9'-11" f	9'-0"	
250PS125-22	24	14'-8"	11'-7"	10'-2"	12'-9"	10'-2"	8'-7"	11'-7"	9'-0"		8'-1" f		
350PS125-15	12	20'-0"	15'-10"	13'-10"	17'-6"	13'-10"	12'-1"	15'-10" f	12'-7"	11'-0"	10'-5" f	10'-5" f	9'-6"
350PS125-15	16	18'-2"	14'-5"	12'-7"	15'-10" f	12'-7"	11'-0"	13'-9" f	11'-5"	10'-0"	9'-0" f	9'-0" f	8'-6"
350PS125-15	24	15'-10" f	12'-7"	11'-0"	12'-11" f	11'-0"	9'-6"	11'-2" f	10'-0"	8'-6"			
350PS125-22	12	22'-9"	18'-1"	15'-10"	19'-11"	15'-10"	13'-10"	18'-1"	14'-4"	12'-6"	13'-6" f	12'-6"	10'-11"
350PS125-22	16	20'-8"	16'-5"	14'-4"	18'-1"	14'-4"	12'-6"	16'-5"	13'-1"	11'-5"	11'-8" f	11'-5"	9'-11"
350PS125-22	24	18'-1"	14'-4"	12'-6"	15'-10"	12'-6"	10'-11"	14'-4"	11'-5"	9'-11"	9'-6" f	9'-6"	8'-7"
362PS125-15	12	21'-0"	16'-8"	14'-7"	18'-4"	14'-7"	12'-9"	15'-11" f	13'-3"	11'-7"	10'-6" f	10'-6" f	9'-11"
362PS125-15	16	19'-1"	15'-2"	13'-3"	15'-11" f	13'-3"	11'-7"	13'-10" f	12'-0"	10'-4"	9'-1" f	9'-1" f	8'-10"
362PS125-15	24	15'-11" f	13'-3"	11'-7"	13'-0" f	11'-7"	9'-11"	11'-3" f	10'-4"	8'-10"			
362PS125-22	12	23'-9"	18'-11"	16'-6"	20'-9"	16'-6"	14'-5"	18'-11"	15'-0"	13'-1"	14'-1" f	13'-1"	11'-4"
362PS125-22	16	21'-7"	17'-2"	15'-0"	18'-11"	15'-0"	13'-1"	17'-2"	13'-7"	11'-10"	12'-3" f	11'-10"	10'-3"
362PS125-22	24	18'-11"	15'-0"	13'-1"	16'-6"	13'-1"	11'-4"	15'-0"	11'-10"	10'-3"	10'-0" f	10'-0" f	
400PS125-15	12	22'-1"	17'-6"	15'-4"	19'-4"	15'-4"	13'-5"	16'-11" f	13'-11"	12'-2"	11'-2" f	11'-2" f	10'-4"
400PS125-15	16	20'-1"	15'-11"	13'-11"	16'-11" f	13'-11"	12'-2"	14'-8" f	12'-8"	10'-10"	9'-8" f	9'-8" f	9'-2"
400PS125-15	24	16'-11" f	13'-11"	12'-2"	13'-10" f	12'-2"	10'-4"	12'-0" f	10'-10"	9'-2"			
400PS125-22	12	25'-4"	20'-1"	17'-7"	22'-1"	17'-7"	15'-4"	20'-1"	15'-11"	13'-11"	14'-3" f	13'-11"	12'-1"
400PS125-22	16	23'-0"	18'-3"	15'-11"	20'-1"	15'-11"	13'-11"	18'-3"	14'-6"	12'-8"	12'-4" f	12'-4" f	10'-11"
400PS125-22	24	20'-1"	15'-11"	13'-11"	17'-7"	13'-11"	12'-1"	15'-4" f	12'-8"	10'-11"	10'-1" f	10'-1" f	9'-5"
550PS125-15	12	26'-11"	21'-4"	18'-8"	23'-0" f	18'-8"	16'-4"	19'-11" f	16'-11"	14'-10"	13'-1" f	13'-1" f	12'-10"
550PS125-15	16	24'-5" f	19'-5"	16'-11"	19'-11" f	16'-11"	14'-10"	17'-3" f	15'-5"	13'-5"	11'-4" f	11'-4" f	11'-4" f
550PS125-15	24	19'-11" f	16'-11"	14'-10"	16'-3" f	14'-10"	12'-10"	14'-1" f	13'-5"	11'-5"	9'-3" f	9'-3" f	9'-3" f
550PS125-22	12	30'-11"	24'-7"	21'-6"	27'-1"	21'-6"	18'-9"	24'-7"	19'-6"	17'-0"	16'-5" f	16'-5" f	14'-11"
550PS125-22	16	28'-2"	22'-4"	19'-6"	24'-7"	19'-6"	17'-0"	21'-8" f	17'-9"	15'-6"	14'-3" f	14'-3" f	13'-6"
550PS125-22	24	24'-7"	19'-6"	17'-0"	20'-5" f	17'-0"	14'-11"	17'-8" f	15'-6"	13'-6"	11'-7" f	11'-7" f	11'-7" f
600PS125-15	12	28'-0"	22'-9"	20'-6"	24'-1" f	19'-11"	17'-11"	20'-10" f	18'-1"	16'-3"	13'-8" f	13'-8" f	13'-8" f
600PS125-15	16	25'-6"	20'-8"	18'-7"	20'-10" f	18'-1"	16'-3"	18'-1" f	16'-5"	14'-9"	11'-10" f	11'-10" f	11'-10" f
600PS125-15	24	20'-10" f	18'-1"	16'-3"	17'-0" f	15'-9"	14'-2"	14'-9" f	14'-3"	12'-8"			
600PS125-22	12	33'-10"	26'-0"	23'-0"	29'-7"	22'-8"	20'-1"	25'-10" f	20'-7"	18'-3"	17'-0" f	17'-0" f	15'-11"
600PS125-22	16	30'-9"	23'-7"	20'-11"	25'-10" f	20'-7"	18'-3"	22'-4" f	18'-9"	16'-7"	14'-8" f	14'-8" f	14'-6"
600PS125-22	24	25'-10" f	20'-7"	18'-3"	21'-1" f	18'-0"	15'-11"	18'-3" f	16'-4"	14'-6"	12'-0" f	12'-0" f	12'-0" f

Limiting Wall Heights

Interior Non-Structural Composite Table Notes

1. Allowable composite limiting heights are calculated using ICC-ES AC86-2010. In accordance with current building codes and AISI design standards, the 1/3 Stress Increase for strength was not used.
2. The composite limiting heights provided in the table are based on a single layer of 5/8" thick Type X USG Gypsum board complying with ASTM C1396.
3. The gypsum board must be applied full height in the vertical orientation to each stud flange and installed using minimum No. 6 Type S Drywall screws spaced a minimum of 12-in on-center to the framing members.
4. No fasteners are required for attaching the stud to the track except as detailed in ASTM C754.
5. Stud end bearing must be a minimum of 1 inch.
6. Material yield strength equals 70 ksi for 15Mil and 18Mil studs, 65 ksi for 22Mil and 26Mil studs, and 33 ksi for 30Mil and 33Mil studs
7. 'f' adjacent to the height value indicates that flexural stress controls the allowable wall height.
8. 's' adjacent to the height value indicates that shear/end reaction controls the allowable wall height.

Interior Composite data with 1 layer 5/8" Type X Gypsum Board

Section	Spacing (in) o.c.	5 psf			7.5 psf			10 psf			15 psf		
		L/120	L/240	L/360	L/120	L/240	L/360	L/120	L/240	L/360	L/120	L/240	L/360
162PS125-26	12	15' - 3"	12' - 1"	10' - 7"	13' - 4"	10' - 7"	9' - 1"	12' - 1"	9' - 7"	8' - 1"	10' - 7"	8' - 1"	
162PS125-26	16	13' - 10"	11' - 0"	9' - 7"	12' - 1"	9' - 7"	8' - 1"	11' - 0"	8' - 6"		9' - 7"		
162PS125-26	24	12' - 1"	9' - 7"	8' - 1"	10' - 7"	8' - 1"		9' - 7"			7' - 10" f f		
162PS125-33	12	15' - 10"	12' - 7"	11' - 0"	13' - 10"	11' - 0"	9' - 7"	12' - 7"	10' - 0"	8' - 6"	11' - 0"	8' - 6"	
162PS125-33	16	14' - 5"	11' - 5"	10' - 0"	12' - 7"	10' - 0"	8' - 6"	11' - 5"	8' - 11"		10' - 0"		
162PS125-33	24	12' - 7"	10' - 0"	8' - 6"	11' - 0"	8' - 6"		10' - 0"			8' - 5" f f		
250PS125-26	12	18' - 10"	15' - 0"	13' - 1"	16' - 6"	13' - 1"	11' - 5"	15' - 0"	11' - 11"	10' - 5"	12' - 8" f	10' - 5"	8' - 10"
250PS125-26	16	17' - 2"	13' - 7"	11' - 11"	15' - 0"	11' - 11"	10' - 5"	13' - 7"	10' - 9"	9' - 4"	11' - 0" f	9' - 4"	7' - 10"
250PS125-26	24	15' - 0"	11' - 11"	10' - 5"	13' - 1"	10' - 5"	8' - 10"	11' - 11"	9' - 4"	7' - 10"	9' - 0" f	7' - 10"	
250PS125-33	12	20' - 0"	15' - 11"	13' - 10"	17' - 6"	13' - 10"	12' - 1"	15' - 11"	12' - 7"	11' - 0"	13' - 10"	11' - 0"	9' - 7"
250PS125-33	16	18' - 2"	14' - 5"	12' - 7"	15' - 11"	12' - 7"	11' - 0"	14' - 5"	11' - 5"	10' - 0"	12' - 1" f	10' - 0"	8' - 6"
250PS125-33	24	15' - 11"	12' - 7"	11' - 0"	13' - 10"	11' - 0"	9' - 7"	12' - 7"	10' - 0"	8' - 6"	9' - 11" f	8' - 6"	
350PS125-26	12	23' - 6"	18' - 8"	16' - 3"	20' - 6"	16' - 3"	14' - 3"	18' - 8"	14' - 10"	12' - 11"	15' - 1" f	12' - 11"	11' - 3"
350PS125-26	16	21' - 4"	16' - 11"	14' - 10"	18' - 8"	14' - 10"	12' - 11"	16' - 11"	13' - 5"	11' - 9"	13' - 1" f	11' - 9"	10' - 3"
350PS125-26	24	18' - 8"	14' - 10"	12' - 11"	16' - 3"	12' - 11"	11' - 3"	14' - 10"	11' - 9"	10' - 3"	10' - 8" f	10' - 3"	8' - 10"
350PS125-33	12	25' - 7"	20' - 4"	17' - 9"	22' - 4"	17' - 9"	15' - 6"	20' - 4"	16' - 2"	14' - 1"	16' - 7" f	14' - 1"	12' - 4"
350PS125-33	16	23' - 3"	18' - 6"	16' - 2"	20' - 4"	16' - 2"	14' - 1"	18' - 6"	14' - 8"	12' - 10"	14' - 4" f	12' - 10"	11' - 2"
350PS125-33	24	20' - 4"	16' - 2"	14' - 1"	17' - 9"	14' - 1"	12' - 4"	16' - 2"	12' - 10"	11' - 2"	11' - 8" f	11' - 2"	9' - 8"
362PS125-26	12	24' - 5"	19' - 5"	16' - 11"	21' - 4"	16' - 11"	14' - 10"	19' - 5"	15' - 5"	13' - 5"	15' - 4" f	13' - 5"	11' - 8"
362PS125-26	16	22' - 2"	17' - 7"	15' - 5"	19' - 5"	15' - 5"	13' - 5"	17' - 7"	14' - 0"	12' - 2"	13' - 4" f	12' - 2"	10' - 6"
362PS125-26	24	19' - 5"	15' - 5"	13' - 5"	16' - 11"	13' - 5"	11' - 8"	15' - 5"	12' - 2"	10' - 6"	10' - 10" f	10' - 6"	
362PS125-33	12	26' - 1"	20' - 9"	18' - 1"	22' - 10"	18' - 1"	15' - 10"	20' - 9"	16' - 6"	14' - 5"	17' - 4" f	14' - 5"	12' - 6"
362PS125-33	16	23' - 9"	18' - 10"	16' - 6"	20' - 9"	16' - 6"	14' - 5"	18' - 10"	14' - 11"	13' - 1"	15' - 0" f	13' - 1"	11' - 3"
362PS125-33	24	20' - 9"	16' - 6"	14' - 5"	18' - 1"	14' - 5"	12' - 6"	16' - 6"	13' - 1"	11' - 3"	12' - 3" f	11' - 3"	9' - 9"
400PS125-26	12	26' - 1"	20' - 8"	18' - 1"	22' - 9"	18' - 1"	15' - 10"	20' - 8"	16' - 5"	14' - 4"	16' - 3" f	14' - 4"	12' - 6"
400PS125-26	16	23' - 8"	18' - 10"	16' - 5"	20' - 8"	16' - 5"	14' - 4"	18' - 10"	14' - 11"	13' - 0"	14' - 1" f	13' - 0"	11' - 3"
400PS125-26	24	20' - 8"	16' - 5"	14' - 4"	18' - 1"	14' - 4"	12' - 6"	16' - 5"	13' - 0"	11' - 3"	11' - 6" f	11' - 3"	9' - 9"
400PS125-33	12	28' - 1"	22' - 3"	19' - 5"	24' - 6"	19' - 5"	17' - 0"	22' - 3"	17' - 8"	15' - 5"	17' - 7" f	15' - 5"	13' - 6"
400PS125-33	16	25' - 6"	20' - 3"	17' - 8"	22' - 3"	17' - 8"	15' - 5"	20' - 3"	16' - 1"	14' - 0"	15' - 3" f	14' - 0"	12' - 3"
400PS125-33	24	22' - 3"	17' - 8"	15' - 5"	19' - 5"	15' - 5"	13' - 6"	17' - 8"	14' - 0"	12' - 3"	12' - 5" f	12' - 3"	10' - 7"
550PS125-26	12	32' - 1"	25' - 6"	22' - 3"	28' - 1"	22' - 3"	19' - 5"	25' - 6"	20' - 3"	17' - 8"	19' - 2" f	17' - 8"	15' - 5"
550PS125-26	16	29' - 2"	23' - 2"	20' - 3"	25' - 6"	20' - 3"	17' - 8"	23' - 2"	18' - 5"	16' - 1"	16' - 7" f	16' - 1"	14' - 0"
550PS125-26	24	25' - 6"	20' - 3"	17' - 8"	22' - 3"	17' - 8"	15' - 5"	20' - 3"	16' - 1"	14' - 0"	13' - 7" f	13' - 7" f	12' - 1"
550PS125-33	12	34' - 7"	27' - 6"	24' - 0"	30' - 3"	24' - 0"	21' - 0"	27' - 6"	21' - 10"	19' - 1"	20' - 4" f	19' - 1"	16' - 8"
550PS125-33	16	31' - 5"	24' - 11"	21' - 10"	27' - 6"	21' - 10"	19' - 1"	24' - 11"	19' - 10"	17' - 4"	17' - 7" f	17' - 4"	15' - 1"
550PS125-33	24	27' - 6"	21' - 10"	19' - 1"	24' - 0"	19' - 1"	16' - 8"	21' - 10"	17' - 4"	15' - 1"	14' - 5" f	14' - 5" f	13' - 2"
600PS125-26	12	34' - 3"	27' - 2"	23' - 9"	29' - 11"	23' - 9"	20' - 9"	27' - 2"	21' - 7"	18' - 10"	20' - 1" f	18' - 10"	16' - 6"
600PS125-26	16	31' - 2"	24' - 9"	21' - 7"	27' - 2"	21' - 7"	18' - 10"	24' - 9"	19' - 7"	17' - 2"	17' - 5" f	17' - 2"	14' - 11"
600PS125-26	24	27' - 2"	21' - 7"	18' - 10"	23' - 9"	18' - 10"	16' - 6"	21' - 7"	17' - 2"	14' - 11"	14' - 2" f	14' - 2" f	12' - 10"
600PS125-33	12	36' - 9"	29' - 2"	25' - 6"	32' - 3"	25' - 6"	22' - 3"	29' - 2"	23' - 2"	20' - 3"	21' - 1" f	20' - 3"	17' - 8"
600PS125-33	16	33' - 5"	26' - 6"	23' - 2"	29' - 2"	23' - 2"	20' - 3"	26' - 6"	21' - 0"	18' - 5"	18' - 3" f	18' - 3" f	16' - 1"
600PS125-33	24	29' - 2"	23' - 2"	20' - 3"	25' - 6"	20' - 3"	17' - 8"	22' - 8" f	18' - 5"	16' - 1"	14' - 11" f	14' - 11" f	14' - 0"

Limiting Wall Heights

Interior Non-Structural Non-Composite Table Notes

1. Heights are based on AISI NASPEC 2001 w/ 2004 Supplement (S100) using steel properties alone.
2. Limiting heights based on continuous support of each flange over the full length of the stud or discrete stud bracing spaced at a distance of Lu or less.
3. Distance of unbraced length (Lu) varies per ProSTUD member. Lu is listed in the physical and structural properties.
4. Heights are limited by moment, deflection, shear, and web crippling (assuming 1" end reaction bearing).
5. Minimum material yield strength equals 70 ksi for 15-mil and 18-mil studs and 65 ksi for 22-mil studs.
6. "f" Indicates that flexural stress controls the allowable wall height.
7. "s" Indicates that shear/end reaction controls the allowable wall height.
8. "()" indicates that higher heights can be achieved by using end bearing stiffeners.

Interior Non-Composite data – Fully Braced

Section	Spacing (in) o.c.	5 psf			7.5 psf			10 psf			15 psf		
		L/120	L/240	L/360	L/120	L/240	L/360	L/120	L/240	L/360	L/120	L/240	L/360
162PS125-15	12	9'-0"	7'-1"	6'-3"	7'-10"	6'-3"	5'-5"	7'-1"	5'-8"	4'-11"	6'-3"	4'-11"	4'-4"
162PS125-15	16	8'-2"	6'-6"	5'-8"	7'-1"	5'-8"	4'-11"	6'-6"	5'-2"	4'-6"	5'-6" f	4'-6"	3'-11"
162PS125-15	24	7'-1"	5'-8"	4'-11"	6'-3"	4'-11"	4'-4"	5'-6" f	4'-6"	3'-11"	4'-6" f	3'-11"	3'-5"
250PS125-15	12	12'-8"	10'-1"	8'-9"	11'-1"	8'-9"	7'-8"	10'-1"	8'-0"	7'-0"	8'-5" f	7'-0"	6'-1"
250PS125-15	16	11'-6"	9'-2"	8'-0"	10'-1"	8'-0"	7'-0"	8'-11" f	7'-3"	6'-4"	7'-3" f	6'-4"	5'-6"
250PS125-15	24	10'-1"	8'-0"	7'-0"	8'-5" f	7'-0"	6'-1"	7'-3" f	6'-4"	5'-6"	5'-11" (5'-11") f	5'-6"	4'-10"
350PS125-15	12	15'-8"	12'-5"	10'-11"	13'-6" f	10'-11"	9'-6"	11'-8" f	9'-11"	8'-8"	9'-7" f	8'-8"	7'-6"
350PS125-15	16	14'-3"	11'-4"	9'-11"	11'-8" f	9'-11"	8'-8"	10'-1" f	9'-0"	7'-10"	7'-9" (8'-3") f	7'-9" (7'-10")	6'-10"
350PS125-15	24	11'-8" f	9'-11"	8'-8"	9'-7" f	8'-8"	7'-6"	7'-9" (8'-3") f	7'-9" (7'-10")	6'-10"	5'-2" (6'-9") f	5'-2" (6'-9") f	5'-2" (6'-0")
362PS125-15	12	16'-1"	12'-9"	11'-2"	13'-9" f	11'-2"	9'-9"	11'-11" f	10'-2"	8'-10"	9'-9" f	8'-10"	7'-9"
362PS125-15	16	14'-7" f	11'-7"	10'-2"	11'-11" f	10'-2"	8'-10"	10'-4" f	9'-3"	8'-1"	7'-5" (8'-5") f	7'-5" (8'-1")	7'-0"
362PS125-15	24	11'-11" f	10'-2"	8'-10"	9'-9" f	8'-10"	7'-9"	7'-5" (8'-5") f	7'-5" (8'-1")	7'-0"	4'-11" (6'-8") s	4'-11" (6'-8") s	4'-11" (6'-2")
400PS125-15	12	17'-4"	13'-9"	12'-0"	14'-6" f	12'-0"	10'-6"	12'-7" f	10'-11"	9'-6"	8'-9" (10'-3") f	8'-9" (9'-6")	8'-4"
400PS125-15	16	15'-4" f	12'-6"	10'-11"	12'-7" f	10'-11"	9'-6"	9'-10" (10'-10") f	9'-10" (9'-11")	8'-8"	6'-7" (8'-11") f	6'-7" (8'-8")	6'-7" (7'-7")
400PS125-15	24	12'-7" f	10'-11"	9'-6"	8'-9" (10'-3") f	8'-9" (9'-6")	8'-4"	6'-7" (8'-11") f	6'-7" (8'-8")	6'-7" (7'-7")	4'-4" (6'-0") s	4'-4" (6'-0") s	4'-4" (6'-0") s
162PS125-18	12	9'-7"	7'-7"	6'-7"	8'-4"	6'-7"	5'-9"	7'-7"	6'-0"	5'-3"	6'-7"	5'-3"	4'-7"
162PS125-18	16	8'-8"	6'-11"	6'-0"	7'-7"	6'-0"	5'-3"	6'-11"	5'-6"	4'-9"	6'-0"	4'-9"	4'-2"
162PS125-18	24	7'-7"	6'-0"	5'-3"	6'-7"	5'-3"	4'-7"	6'-0"	4'-9"	4'-2"	5'-0" f	4'-2"	3'-8"
250PS125-18	12	13'-5"	10'-8"	9'-3"	11'-8"	9'-3"	8'-1"	10'-8"	8'-5"	7'-4"	9'-3" f	7'-4"	6'-5"
250PS125-18	16	12'-2"	9'-8"	8'-5"	10'-8"	8'-5"	7'-4"	9'-8"	7'-8"	6'-8"	8'-3" f	6'-8"	5'-10"
250PS125-18	24	10'-8"	8'-5"	7'-4"	9'-3" f	7'-4"	6'-5"	8'-3" f	6'-8"	5'-10"	6'-9" f	5'-10"	5'-1"
350PS125-18	12	16'-9"	13'-3"	11'-7"	14'-8"	11'-7"	10'-2"	13'-3" f	10'-7"	9'-3"	10'-10" f	9'-3"	8'-1"
350PS125-18	16	15'-3"	12'-1"	10'-7"	13'-3" f	10'-7"	9'-3"	11'-5" f	9'-7"	8'-4"	9'-4" f	8'-4"	7'-4"
350PS125-18	24	13'-3" f	10'-7"	9'-3"	10'-10" f	9'-3"	8'-1"	9'-4" f	8'-4"	7'-4"	7'-8" f	7'-4"	6'-5"
362PS125-18	12	17'-2"	13'-8"	11'-11"	15'-0"	11'-11"	10'-5"	13'-6" f	10'-10"	9'-5"	11'-0" f	9'-5"	8'-3"
362PS125-18	16	15'-7"	12'-5"	10'-10"	13'-6" f	10'-10"	9'-5"	11'-8" f	9'-10"	8'-7"	9'-6" f	8'-7"	7'-6"
362PS125-18	24	13'-6" f	10'-10"	9'-5"	11'-0" f	9'-5"	8'-3"	9'-6" f	8'-7"	7'-6"	7'-9" (7'-9") f	7'-6"	6'-7"
400PS125-18	12	18'-6"	14'-8"	12'-10"	16'-2"	12'-10"	11'-2"	14'-2" f	11'-8"	10'-2"	11'-7" f	10'-2"	8'-11"
400PS125-18	16	16'-9"	13'-4"	11'-8"	14'-2" f	11'-8"	10'-2"	12'-4" f	10'-7"	9'-3"	10'-1" f	9'-3"	8'-1"
400PS125-18	24	14'-2" f	11'-8"	10'-2"	11'-7" f	10'-2"	8'-11"	10'-1" f	9'-3"	8'-1"	7'-4" (8'-2") f	7'-4" (8'-1")	7'-1"
162PS125-22	12	10'-4"	8'-3"	7'-2"	9'-1"	7'-2"	6'-3"	8'-3"	6'-6"	5'-8"	7'-2"	5'-8"	5'-0"
162PS125-22	16	9'-5"	7'-6"	6'-6"	8'-3"	6'-6"	5'-8"	7'-6"	5'-11"	5'-2"	6'-6"	5'-2"	4'-6"
162PS125-22	24	8'-3"	6'-6"	5'-8"	7'-2"	5'-8"	5'-0"	6'-6"	5'-2"	4'-6"	5'-8" f	4'-6"	3'-11"
250PS125-22	12	14'-5"	11'-5"	10'-0"	12'-7"	10'-0"	8'-9"	11'-5"	9'-1"	7'-11"	10'-0"	7'-11"	6'-11"
250PS125-22	16	13'-1"	10'-5"	9'-1"	11'-5"	9'-1"	7'-11"	10'-5"	8'-3"	7'-2"	9'-1"	7'-2"	6'-3"
250PS125-22	24	11'-5"	9'-1"	7'-11"	10'-0"	7'-11"	6'-11"	9'-1"	7'-2"	6'-3"	7'-10" f	6'-3"	5'-6"
350PS125-22	12	18'-3"	14'-6"	12'-8"	15'-11"	12'-8"	11'-1"	14'-6"	11'-6"	10'-1"	12'-3" f	10'-1"	8'-9"
350PS125-22	16	16'-7"	13'-2"	11'-6"	14'-6"	11'-6"	10'-1"	13'-0" f	10'-5"	9'-2"	10'-8" f	9'-2"	8'-0"
350PS125-22	24	14'-6"	11'-6"	10'-1"	12'-3" f	10'-1"	8'-9"	10'-8" f	9'-2"	8'-0"	8'-8" f	8'-0"	7'-0"
362PS125-22	12	18'-9"	14'-11"	13'-0"	16'-5"	13'-0"	11'-4"	14'-11"	11'-10"	10'-4"	12'-6" f	10'-4"	9'-0"
362PS125-22	16	17'-0"	13'-6"	11'-10"	14'-11"	11'-10"	10'-4"	13'-3" f	10'-9"	9'-5"	10'-10" f	9'-5"	8'-2"
362PS125-22	24	14'-11"	11'-10"	10'-4"	12'-6" f	10'-4"	9'-0"	10'-10" f	9'-5"	8'-2"	8'-10" f	8'-2"	7'-2"
400PS125-22	12	20'-2"	16'-0"	14'-0"	17'-7"	14'-0"	12'-3"	16'-0"	12'-9"	11'-1"	13'-2" f	11'-1"	9'-8"
400PS125-22	16	18'-4"	14'-7"	12'-9"	16'-0"	12'-9"	11'-1"	14'-0" f	11'-7"	10'-1"	11'-5" f	10'-1"	8'-10"
400PS125-22	24	16'-0"	12'-9"	11'-1"	13'-2" f	11'-1"	9'-8"	11'-5" f	10'-1"	8'-10"	9'-4" f	8'-10"	7'-8"
550PS125-22	12	25'-11"	20'-7"	17'-11"	22'-7"	17'-11"	15'-8"	19'-11" f	16'-4"	14'-3"	16'-3" f	14'-3"	12'-5"
550PS125-22	16	23'-6"	18'-8"	16'-4"	19'-11" f	16'-4"	14'-3"	17'-3" f	14'-10"	12'-11"	12'-11" (14'-1") f	12'-11" (12'-11")	11'-4"
550PS125-22	24	19'-11" f	16'-4"	14'-3"	16'-3" f	14'-3"	12'-5"	12'-11" (14'-1") f	12'-11" (12'-11")	11'-4"	8'-7" (11'-6") f	8'-7" (11'-4")	8'-7" (9'-11")
600PS125-22	12	27'-7"	21'-11"	19'-2"	24'-0" f	19'-2"	16'-9"	20'-10" f	17'-5"	15'-2"	15'-5" (17'-0") f	15'-2"	13'-3"
600PS125-22	16	25'-1"	19'-11"	17'-5"	20'-10" f	17'-5"	15'-2"	17'-5" (18'-0") f	15'-10"	13'-10"	11'-7" (14'-9") f	11'-7" (13'-10")	11'-7" (12'-1")
600PS125-22	24	20'-10" f	17'-5"	15'-2"	15'-5" (17'-0") f	15'-2"	13'-3"	11'-7" (14'-9") f	11'-7" (13'-10")	11'-7" (12'-1")	7'-9" (12'-0") f	7'-9" (12'-0") f	7'-9" (10'-6")

Limiting Wall Heights

Interior Non-Structural Non-Composite Table Notes

1. Heights are based on AISI NASPEC 2001 w/ 2004 Supplement (S100) using steel properties alone.
2. Limiting heights based on continuous support of each flange over the full length of the stud or discrete stud bracing spaced at a distance of Lu or less.
3. Distance of unbraced length (Lu) varies per ProSTUD member. Lu is listed in the physical and structural properties.
4. Heights are limited by moment, deflection, shear, and web crippling (assuming 1" end reaction bearing).
5. Minimum material yield strength equals 70 ksi for 15-mil and 18-mil studs and 65 ksi for 22-mil studs.
6. "f" Indicates that flexural stress controls the allowable wall height.
7. "s" Indicates that shear/end reaction controls the allowable wall height.
8. "(f)" indicates that higher heights can be achieved by using end bearing stiffeners.

Interior Non-Composite data – Fully Braced

Section	Spacing (in) o.c.	5 psf			7.5 psf			10 psf			15 psf		
		L/120	L/240	L/360	L/120	L/240	L/360	L/120	L/240	L/360	L/120	L/240	L/360
162PS125-26	12	11'-0"	8'-9"	7'-7"	9'-7"	7'-7"	6'-8"	8'-9"	6'-11"	6'-1"	7'-7"	6'-1"	5'-3"
162PS125-26	16	10'-0"	7'-11"	6'-11"	8'-9"	6'-11"	6'-1"	7'-11"	6'-3"	5'-6"	6'-11"	5'-6"	4'-10"
162PS125-26	24	8'-9"	6'-11"	6'-1"	7'-7"	6'-1"	5'-3"	6'-11"	5'-6"	4'-10"	6'-1"	4'-10"	4'-2"
250PS125-26	12	15'-3"	12'-1"	10'-7"	13'-4"	10'-7"	9'-3"	12'-1"	9'-7"	8'-5"	10'-7"	8'-5"	7'-4"
250PS125-26	16	13'-10"	11'-0"	9'-7"	12'-1"	9'-7"	8'-5"	11'-0"	8'-9"	7'-8"	9'-7"	7'-8"	6'-8"
250PS125-26	24	12'-1"	9'-7"	8'-5"	10'-7"	8'-5"	7'-4"	9'-7"	7'-8"	6'-8"	8'-5"	6'-8"	5'-10"
350PS125-26	12	19'-6"	15'-5"	13'-6"	17'-0"	13'-6"	11'-9"	15'-5"	12'-3"	10'-9"	13'-6"	10'-9"	9'-4"
350PS125-26	16	17'-8"	14'-0"	12'-3"	15'-5"	12'-3"	10'-9"	14'-0"	11'-2"	9'-9"	12'-0"	9'-9"	8'-6"
350PS125-26	24	15'-5"	12'-3"	10'-9"	13'-6"	10'-9"	9'-4"	12'-0"	9'-9"	8'-6"	9'-10"	8'-6"	7'-5"
362PS125-26	12	20'-0"	15'-10"	13'-10"	17'-6"	13'-10"	12'-1"	15'-10"	12'-7"	11'-0"	13'-10"	11'-0"	9'-7"
362PS125-26	16	18'-2"	14'-5"	12'-7"	15'-10"	12'-7"	11'-0"	14'-5"	11'-5"	10'-0"	12'-3"	10'-0"	8'-9"
362PS125-26	24	15'-10"	12'-7"	11'-0"	13'-10"	11'-0"	9'-7"	12'-3"	f	10'-0"	10'-0"	f	8'-9"
400PS125-26	12	21'-6"	17'-1"	14'-11"	18'-10"	14'-11"	13'-1"	17'-1"	13'-7"	11'-10"	14'-11"	f	11'-10"
400PS125-26	16	19'-7"	15'-6"	13'-7"	17'-1"	13'-7"	11'-10"	15'-6"	12'-4"	10'-9"	12'-11"	f	10'-9"
400PS125-26	24	17'-1"	13'-7"	11'-10"	14'-11"	f	11'-10"	12'-11"	f	10'-9"	9'-5"	10'-7"	8'-3"
550PS125-26	12	27'-8"	22'-0"	19'-3"	24'-2"	19'-3"	16'-9"	22'-0"	17'-5"	15'-3"	18'-5"	f	15'-3"
550PS125-26	16	25'-2"	20'-0"	17'-5"	22'-0"	17'-5"	15'-3"	19'-7"	f	15'-10"	13'-10"	f	12'-1"
550PS125-26	24	22'-0"	17'-5"	15'-3"	18'-5"	f	15'-3"	16'-0"	f	13'-10"	12'-1"	f	10'-7"
600PS125-26	12	29'-7"	23'-6"	20'-6"	25'-10"	20'-6"	17'-11"	23'-6"	18'-7"	16'-3"	19'-4"	f	16'-3"
600PS125-26	16	26'-10"	21'-4"	18'-7"	23'-6"	18'-7"	16'-3"	20'-6"	f	16'-11"	14'-9"	f	14'-9"
600PS125-26	24	23'-6"	18'-7"	16'-3"	19'-4"	f	16'-3"	16'-9"	f	14'-9"	12'-11"	12'-9"	(13'-8") f
162PS125-30	12	11'-10"	9'-4"	8'-2"	10'-4"	8'-2"	7'-2"	9'-4"	7'-5"	6'-6"	7'-8"	f	6'-6"
162PS125-30	16	10'-9"	8'-6"	7'-5"	9'-4"	7'-5"	6'-6"	8'-2"	f	6'-9"	6'-8"	f	5'-11"
162PS125-30	24	9'-4"	7'-5"	6'-6"	7'-8"	f	6'-6"	6'-8"	f	5'-11"	5'-2"	f	4'-6"
250PS125-30	12	16'-5"	13'-0"	11'-4"	14'-4"	11'-4"	9'-11"	12'-7"	f	10'-4"	9'-0"	f	7'-11"
250PS125-30	16	14'-11"	11'-10"	10'-4"	12'-7"	f	10'-4"	10'-11"	f	9'-5"	8'-2"	f	7'-2"
250PS125-30	24	12'-7"	f	10'-4"	10'-4"	f	9'-0"	8'-11"	f	8'-2"	7'-3"	f	6'-3"
350PS125-30	12	21'-0"	16'-8"	14'-7"	17'-3"	f	14'-7"	14'-11"	f	13'-3"	11'-7"	f	10'-1"
350PS125-30	16	18'-4"	f	15'-2"	13'-2"	f	11'-7"	12'-11"	f	12'-1"	10'-6"	f	9'-2"
350PS125-30	24	14'-11"	f	13'-3"	11'-7"	f	10'-1"	10'-7"	f	10'-6"	9'-2"	f	8'-0"
362PS125-30	12	21'-7"	f	17'-2"	15'-0"	f	13'-1"	15'-3"	f	13'-7"	11'-11"	f	10'-5"
362PS125-30	16	18'-8"	f	15'-7"	13'-7"	f	11'-11"	13'-2"	f	12'-5"	10'-9"	f	9'-5"
362PS125-30	24	15'-3"	f	13'-7"	11'-11"	f	10'-5"	10'-9"	f	10'-9"	9'-5"	f	8'-3"
400PS125-30	12	22'-10"	f	18'-6"	16'-2"	f	14'-2"	16'-2"	f	14'-8"	12'-2"	f	11'-3"
400PS125-30	16	19'-9"	f	16'-10"	14'-8"	f	12'-10"	14'-0"	f	13'-4"	11'-8"	f	10'-2"
400PS125-30	24	16'-2"	f	14'-8"	12'-10"	f	11'-3"	11'-5"	f	11'-5"	9'-4"	f	8'-11"
550PS125-30	12	28'-5"	f	23'-11"	20'-11"	f	18'-3"	20'-1"	f	19'-0"	16'-5"	f	14'-6"
550PS125-30	16	24'-8"	f	21'-9"	19'-0"	f	16'-7"	17'-5"	f	17'-3"	15'-1"	f	13'-2"
550PS125-30	24	20'-1"	f	19'-0"	16'-7"	f	14'-6"	13'-7"	(14'-3") f	13'-7"	(14'-3") f	9'-1"	(11'-6") f
600PS125-30	12	29'-10"	f	25'-7"	22'-4"	f	19'-7"	21'-1"	f	20'-4"	17'-9"	f	15'-6"
600PS125-30	16	25'-10"	f	23'-3"	20'-4"	f	17'-9"	18'-3"	f	18'-3"	16'-2"	f	13'-4"
600PS125-30	24	21'-1"	f	20'-4"	17'-9"	f	15'-6"	13'-4"	(14'-11") f	13'-4"	(14'-11") f	8'-11"	(12'-2") f
162PS125-33	12	12'-2"	9'-8"	8'-5"	8'-5"	7'-5"	7'-5"	9'-8"	7'-8"	6'-8"	8'-3"	f	6'-8"
162PS125-33	16	11'-1"	8'-9"	7'-8"	7'-8"	6'-8"	6'-8"	8'-9"	7'-8"	6'-1"	7'-2"	f	5'-4"
162PS125-33	24	9'-8"	7'-8"	6'-8"	6'-8"	5'-10"	5'-10"	7'-2"	f	6'-1"	5'-4"	f	4'-8"
250PS125-33	12	16'-11"	13'-5"	11'-9"	11'-9"	10'-3"	10'-3"	13'-5"	10'-8"	9'-4"	11'-0"	f	9'-4"
250PS125-33	16	15'-5"	12'-3"	10'-8"	10'-8"	9'-4"	9'-4"	11'-8"	f	9'-8"	9'-7"	f	8'-6"
250PS125-33	24	13'-5"	10'-8"	9'-4"	9'-4"	8'-2"	8'-2"	9'-7"	f	8'-6"	7'-5"	f	6'-6"
350PS125-33	12	21'-9"	17'-3"	15'-1"	15'-1"	13'-2"	13'-2"	13'-8"	12'-0"	12'-0"	13'-2"	f	12'-0"
350PS125-33	16	19'-9"	15'-8"	13'-8"	13'-8"	12'-0"	12'-0"	14'-0"	f	12'-5"	10'-11"	f	9'-6"
350PS125-33	24	16'-2"	f	13'-8"	12'-0"	f	12'-0"	11'-5"	f	10'-11"	9'-4"	f	9'-4"
362PS125-33	12	22'-4"	17'-9"	15'-6"	15'-6"	13'-7"	13'-7"	16'-6"	f	14'-1"	12'-4"	f	10'-9"
362PS125-33	16	20'-3"	f	16'-2"	14'-1"	12'-4"	12'-4"	14'-4"	f	12'-10"	11'-2"	f	9'-9"
362PS125-33	24	16'-6"	f	14'-1"	12'-4"	10'-9"	10'-9"	11'-8"	f	11'-2"	9'-6"	f	8'-6"
400PS125-33	12	24'-2"	19'-2"	16'-9"	16'-9"	14'-8"	14'-8"	17'-6"	f	15'-3"	13'-3"	f	11'-7"
400PS125-33	16	21'-5"	f	17'-5"	15'-3"	13'-3"	13'-3"	15'-2"	f	13'-10"	12'-1"	f	10'-7"
400PS125-33	24	17'-6"	f	15'-3"	13'-3"	11'-7"	11'-7"	12'-4"	f	12'-1"	10'-7"	f	9'-3"
550PS125-33	12	30'-10"	f	24'-10"	21'-8"	18'-11"	18'-11"	21'-10"	f	19'-8"	17'-3"	f	15'-0"
550PS125-33	16	26'-9"	f	22'-7"	19'-8"	16'-8"	16'-8"	18'-11"	f	17'-11"	15'-5"	f	13'-8"
550PS125-33	24	21'-10"	f	19'-8"	17'-3"	15'-0"	15'-0"	15'-5"	f	15'-5"	13'-8"	f	11'-1"
600PS125-33	12	32'-5"	f	26'-7"	23'-2"	20'-3"	20'-3"	22'-11"	f	21'-1"	18'-5"	f	16'-1"
600PS125-33	16	28'-1"	f	24'-1"	21'-1"	18'-5"	18'-5"	19'-10"	f	19'-2"	16'-9"	f	14'-7"
600PS125-33	24	22'-11"	f	21'-1"	18'-5"	16'-1"	16'-1"	16'-2"	f	16'-2"	14'-7"	f	12'-9"

Limiting Wall Heights

Interior Non-Structural Non-Composite Table Notes

1. Heights are based on AISI NASPEC 2001 w/ 2004 Supplement (S100) using steel properties alone.
2. Limiting heights based on discrete stud bracing spaced at a distance of 48" O.C. or less.
3. Distance of unbraced length (Lu) varies per ProSTUD member. Lu is listed in the physical and structural properties.
4. Heights are limited by moment, deflection, shear, and web crippling (assuming 1" end reaction bearing).
5. Minimum material yield strength equals 70 ksi for 15-mil and 18-mil studs and 65 ksi for 22-mil studs.
6. "f" Indicates that flexural stress controls the allowable wall height.
7. "s" Indicates that shear/end reaction controls the allowable wall height.
8. "(" indicates that higher heights can be achieved by using end bearing stiffeners.

Interior Non-Composite data – Braced at 48" O.C.

Section	Spacing (in) o.c.	5 psf			7.5 psf			10 psf			15 psf		
		L/120	L/240	L/360	L/120	L/240	L/360	L/120	L/240	L/360	L/120	L/240	L/360
162PS125-15	12	9'-0"	7'-1"	6'-3"	7'-5" f	6'-3"	5'-5"	6'-5" f	5'-8"	4'-11"	5'-3" f	4'-11"	4'-4"
162PS125-15	16	7'-10" f	6'-6"	5'-8"	6'-5" f	5'-8"	4'-11"	5'-7" f	5'-2"	4'-6"	4'-7" f	4'-6"	3'-11"
162PS125-15	24	6'-5" f	5'-8"	4'-11"	5'-3" f	4'-11"	4'-4"	4'-7" f	4'-6"	3'-11"	3'-9" f	3'-9" f	3'-5"
250PS125-15	12	12'-3" f	10'-1"	8'-9"	10'-0" f	8'-9"	7'-8"	8'-8" f	8'-0"	7'-0"	7'-1" f	7'-0"	6'-1"
250PS125-15	16	10'-7" f	9'-2"	8'-0"	8'-8" f	8'-0"	7'-0"	7'-6" f	7'-3"	6'-4"	6'-1" f	6'-1" f	5'-6"
250PS125-15	24	8'-8" f	8'-0"	7'-0"	7'-1" f	7'-0"	6'-1"	6'-1" f	6'-1"	5'-6"	5'-0" f	5'-0" f	4'-10"
350PS125-15	12	13'-7" f	12'-5"	10'-11"	11'-1" f	10'-11"	9'-6"	9'-8" f	9'-8" f	8'-8"	7'-10" f	7'-10" f	7'-6"
350PS125-15	16	11'-9" f	11'-4"	9'-11"	9'-8" f	9'-8" f	8'-8"	8'-4" f	8'-4" f	7'-10"	6'-10" f	6'-10" f	6'-10" f
350PS125-15	24	9'-8" f	9'-8" f	8'-8"	7'-10" f	7'-10" f	7'-6"	6'-10" f	6'-10" f	6'-10" f	5'-2" (5'-7") f	5'-2" (5'-7") f	5'-2" (5'-7") f
362PS125-15	12	13'-10" f	12'-9"	11'-2"	11'-4" f	11'-2"	9'-9"	9'-10" f	9'-10" f	8'-10"	8'-0" f	8'-0" f	7'-9"
362PS125-15	16	12'-0" f	11'-7"	10'-2"	9'-10" f	9'-10" f	8'-10"	8'-6" f	8'-6" f	8'-1"	6'-11" f	6'-11" f	6'-11" f
362PS125-15	24	9'-10" f	9'-10" f	8'-10"	8'-0" f	8'-0" f	7'-9"	6'-11" f	6'-11" f	6'-11" f	4'-11" (5'-8") f	4'-11" (5'-8") f	4'-11" (5'-8") f
400PS125-15	12	14'-7" f	13'-9"	12'-0"	11'-11" f	11'-11" f	10'-6"	10'-4" f	10'-4" f	9'-6"	10'-4" f	9'-6"	8'-4"
400PS125-15	16	12'-8" f	12'-6"	10'-11"	10'-4" f	10'-4" f	9'-6"	8'-11" f	8'-11" f	8'-8"	6'-7" (7'-3") f	6'-7" (7'-3") f	6'-7" (7'-3") f
400PS125-15	24	10'-4" f	10'-4" f	9'-6"	8'-5" f	8'-5" f	8'-4"	6'-7" (7'-3") f	6'-7" (7'-3") f	6'-7" (7'-3") f	4'-4" (5'-11") f	4'-4" (5'-11") f	4'-4" (5'-11") f
162PS125-18	12	9'-7"	7'-7"	6'-7"	8'-3" f	6'-7"	5'-9"	7'-2" f	6'-0"	5'-3"	5'-10" f	5'-3"	4'-7"
162PS125-18	16	8'-8"	6'-11"	6'-0"	7'-2" f	6'-0"	5'-3"	5'-6" f	5'-6" f	4'-9"	5'-1" f	4'-9"	4'-2"
162PS125-18	24	7'-2" f	6'-0"	5'-3"	5'-10" f	5'-3"	4'-7"	5'-1" f	4'-9"	4'-2"	4'-2" f	4'-2" f	3'-8"
250PS125-18	12	13'-5"	10'-8"	9'-3"	11'-3" f	9'-3"	8'-1"	9'-9" f	8'-5"	7'-4"	8'-0" f	7'-4"	6'-5"
250PS125-18	16	11'-11" f	9'-8"	8'-5"	9'-9" f	8'-5"	7'-4"	8'-5" f	7'-8"	6'-8"	6'-11" f	6'-8"	5'-10"
250PS125-18	24	9'-9" f	8'-5"	7'-4"	8'-0" f	7'-4"	6'-5"	6'-11" f	6'-8"	5'-10"	5'-8" f	5'-8" f	5'-1"
350PS125-18	12	15'-3" f	13'-3"	11'-7"	12'-5" f	11'-7"	10'-2"	10'-9" f	10'-9" f	9'-3"	8'-10" f	8'-10" f	8'-1"
350PS125-18	16	13'-2" f	12'-1"	10'-7"	10'-9" f	10'-7"	9'-3"	9'-4" f	9'-4" f	8'-4"	7'-7" f	7'-7" f	7'-4"
350PS125-18	24	10'-9" f	10'-7"	9'-3"	8'-10" f	8'-10" f	8'-1"	7'-7" f	7'-7" f	7'-4"	6'-3" f	6'-3" f	6'-3" f
362PS125-18	12	15'-6" f	13'-8"	11'-11"	12'-8" f	11'-11"	10'-5"	11'-0" f	10'-10"	9'-5"	9'-0" f	9'-0" f	8'-3"
362PS125-18	16	13'-5" f	12'-5"	10'-10"	11'-0" f	10'-10"	9'-5"	9'-6" f	9'-6" f	8'-7"	7'-9" f	7'-9" f	7'-6"
362PS125-18	24	11'-0" f	10'-10"	9'-5"	9'-0" f	9'-0" f	8'-3"	7'-9" f	7'-9" f	7'-6"	6'-4" f	6'-4" f	6'-4" f
400PS125-18	12	16'-4" f	14'-8"	12'-10"	13'-4" f	12'-10"	11'-2"	11'-7" f	11'-7" f	10'-2"	9'-5" f	9'-5" f	8'-11"
400PS125-18	16	14'-2" f	13'-4"	11'-8"	11'-7" f	11'-7" f	10'-2"	10'-0" f	10'-0" f	9'-3"	8'-2" f	8'-2" f	8'-1"
400PS125-18	24	11'-7" f	11'-7" f	10'-2"	9'-5" f	9'-5" f	8'-11"	8'-2" f	8'-2" f	8'-1"	6'-8" f	6'-8" f	6'-8" f
162PS125-22	12	10'-4"	8'-3"	7'-2"	9'-1"	7'-2"	6'-3"	8'-3" f	6'-6"	5'-8"	6'-9" f	5'-8"	5'-0"
162PS125-22	16	9'-5"	7'-6"	6'-6"	8'-3" f	6'-6"	5'-8"	7'-2" f	5'-11"	5'-2"	5'-10" f	5'-2"	4'-6"
162PS125-22	24	8'-3" f	6'-6"	5'-8"	6'-9" f	5'-8"	5'-0"	5'-10" f	5'-2"	4'-6"	4'-9" f	4'-6"	3'-11"
250PS125-22	12	14'-5"	11'-5"	10'-0"	12'-7"	10'-0"	8'-9"	11'-0" f	9'-1"	7'-11"	9'-0" f	7'-11"	6'-11"
250PS125-22	16	13'-1"	10'-5"	9'-1"	11'-0" f	9'-1"	7'-11"	9'-6" f	8'-3"	7'-2"	7'-9" f	7'-2"	6'-3"
250PS125-22	24	11'-0" f	9'-1"	7'-11"	9'-0" f	7'-11"	6'-11"	7'-9" f	7'-2"	6'-3"	6'-4" f	6'-3"	5'-6"
350PS125-22	12	17'-7" f	14'-6"	12'-8"	14'-4" f	12'-8"	11'-1"	12'-5" f	11'-6"	10'-1"	10'-2" f	10'-1"	8'-9"
350PS125-22	16	15'-3" f	13'-2"	11'-6"	12'-5" f	11'-6"	10'-1"	10'-9" f	10'-5"	9'-2"	8'-10" f	8'-10" f	8'-0"
350PS125-22	24	12'-5" f	11'-6"	10'-1"	10'-2" f	10'-1"	8'-9"	8'-10" f	8'-10" f	8'-0"	7'-2" f	7'-2" f	7'-0"
362PS125-22	12	17'-11" f	14'-11"	13'-0"	14'-8" f	13'-0"	11'-4"	12'-8" f	11'-10"	10'-4"	10'-4" f	10'-4" f	9'-0"
362PS125-22	16	15'-6" f	13'-6"	11'-10"	12'-8" f	11'-10"	10'-4"	11'-0" f	10'-9"	9'-5"	9'-0" f	9'-0" f	8'-2"
362PS125-22	24	12'-8" f	11'-10"	10'-4"	10'-4" f	10'-4" f	9'-0"	9'-0" f	9'-0" f	8'-2"	7'-4" f	7'-4" f	7'-2"
400PS125-22	12	18'-11" f	16'-0"	14'-0"	15'-5" f	14'-0"	12'-3"	13'-4" f	12'-9"	11'-1"	10'-11" f	10'-11" f	9'-8"
400PS125-22	16	16'-4" f	14'-7"	12'-9"	13'-4" f	12'-9"	11'-1"	11'-7" f	11'-7" f	10'-1"	9'-5" f	9'-5" f	8'-10"
400PS125-22	24	13'-4" f	12'-9"	11'-1"	10'-11" f	10'-11" f	9'-8"	9'-5" f	9'-5" f	8'-10"	7'-9" f	7'-9" f	7'-8"
550PS125-22	12	23'-0" f	20'-7"	17'-11"	18'-9" f	17'-11"	15'-8"	16'-3" f	16'-3" f	14'-3"	13'-3" f	13'-3" f	12'-5"
550PS125-22	16	19'-11" f	18'-8"	16'-4"	16'-3" f	16'-3" f	14'-3"	14'-1" f	14'-1" f	12'-11"	11'-6" f	11'-6" f	11'-4"
550PS125-22	24	16'-3" f	16'-3" f	14'-3"	13'-3" f	13'-3" f	12'-5"	11'-6" f	11'-6" f	11'-4"	8'-7" (9'-5") f	8'-7" (9'-5") f	8'-7" (9'-5") f
600PS125-22	12	23'-11" f	21'-11"	19'-2"	19'-7" f	19'-2"	16'-9"	16'-11" f	16'-11" f	15'-2"	13'-10" f	13'-10" f	13'-3"
600PS125-22	16	20'-9" f	19'-11"	17'-5"	16'-11" f	16'-11" f	15'-2"	14'-8" f	14'-8" f	13'-10"	11'-7" (12'-0") f	11'-7" (12'-0") f	11'-7" (12'-0") f
600PS125-22	24	16'-11" f	16'-11" f	15'-2"	13'-10" f	13'-10" f	13'-3"	11'-7" (12'-0") f	11'-7" (12'-0") f	11'-7" (12'-0") f	7'-9" (9'-9") f	7'-9" (9'-9") f	7'-9" (9'-9") f

Limiting Wall Heights

Interior Non-Structural Non-Composite Table Notes

1. Heights are based on AISI NASPEC 2001 w/ 2004 Supplement (S100) using steel properties alone.
2. Limiting heights based on discrete stud bracing spaced at a distance of 48" O.C. or less.
3. Distance of unbraced length (Lu) varies per ProSTUD member. Lu is listed in the physical and structural properties.
4. Heights are limited by moment, deflection, shear, and web crippling (assuming 1" end reaction bearing).
5. Minimum material yield strength equals 70 ksi for 15-mil and 18-mil studs and 65 ksi for 22-mil studs.
6. "f" Indicates that flexural stress controls the allowable wall height.
7. "s" Indicates that shear/end reaction controls the allowable wall height.
8. "(" indicates that higher heights can be achieved by using end bearing stiffeners.

Interior Non-Composite data – Braced at 48" O.C.

Section	Spacing (in) o.c.	5 psf			7.5 psf			10 psf			15 psf		
		L/120	L/240	L/360	L/120	L/240	L/360	L/120	L/240	L/360	L/120	L/240	L/360
162PS125-26	12	11'-0"	8'-9"	7'-7"	9'-7"	7'-7"	6'-8"	8'-9"	6'-11"	6'-1"	7'-6" f	6'-1"	5'-3"
162PS125-26	16	10'-0"	7'-11"	6'-11"	8'-9"	6'-11"	6'-1"	7'-11"	6'-3"	5'-6"	6'-6" f	5'-6"	4'-10"
162PS125-26	24	8'-9"	6'-11"	6'-1"	7'-6" f	6'-1"	5'-3"	6'-6" f	5'-6"	4'-10"	5'-4" f	4'-10"	4'-2"
250PS125-26	12	15'-3"	12'-1"	10'-7"	13'-4"	10'-7"	9'-3"	12'-1"	9'-7"	8'-5"	9'-11" f	8'-5"	7'-4"
250PS125-26	16	13'-10"	11'-0"	9'-7"	12'-1"	9'-7"	8'-5"	10'-6" f	8'-9"	7'-8"	8'-7" f	7'-8"	6'-8"
250PS125-26	24	12'-1"	9'-7"	8'-5"	9'-11" f	8'-5"	7'-4"	8'-7" f	7'-8"	6'-8"	7'-0" f	6'-8"	5'-10"
350PS125-26	12	19'-6" f	15'-5"	13'-6"	16'-1" f	13'-6"	11'-9"	14'-0" f	12'-3"	10'-9"	11'-5" f	10'-9"	9'-4"
350PS125-26	16	17'-1" f	14'-0"	12'-3"	14'-0" f	12'-3"	10'-9"	12'-1" f	11'-2"	9'-9"	9'-10" f	9'-9"	8'-6"
350PS125-26	24	14'-0" f	12'-3"	10'-9"	11'-5" f	10'-9"	9'-4"	9'-10" f	9'-9"	8'-6"	8'-1" f	8'-1" f	7'-5"
362PS125-26	12	20'-0" f	15'-10"	13'-10"	16'-5" f	13'-10"	12'-1"	14'-3" f	12'-7"	11'-0"	11'-7" f	11'-0"	9'-7"
362PS125-26	16	17'-5" f	14'-5"	12'-7"	14'-3" f	12'-7"	11'-0"	12'-4" f	11'-5"	10'-0"	10'-1" f	10'-0"	8'-9"
362PS125-26	24	14'-3" f	12'-7"	11'-0"	11'-7" f	11'-0"	9'-7"	10'-1" f	10'-0"	8'-9"	8'-3" f	8'-3" f	7'-8"
400PS125-26	12	21'-3" f	17'-1"	14'-11"	17'-4" f	14'-11"	13'-1"	15'-0" f	13'-7"	11'-10"	12'-3" f	11'-10"	10'-4"
400PS125-26	16	18'-4" f	15'-6"	13'-7"	15'-0" f	13'-7"	11'-10"	13'-0" f	12'-4"	10'-9"	10'-7" f	10'-7" f	9'-5"
400PS125-26	24	15'-0" f	13'-7"	11'-10"	12'-3" f	11'-10"	10'-4"	10'-7" f	10'-7" f	9'-5"	8'-8" f	8'-8" f	8'-3"
550PS125-26	12	25'-11" f	22'-0"	19'-3"	21'-2" f	19'-3"	16'-9"	18'-4" f	17'-5"	15'-3"	15'-0" f	15'-0" f	13'-4"
550PS125-26	16	22'-5" f	20'-0"	17'-5"	18'-4" f	17'-5"	15'-3"	15'-11" f	15'-10"	13'-10"	13'-0" f	13'-0" f	12'-1"
550PS125-26	24	18'-4" f	17'-5"	15'-3"	15'-0" f	15'-0" f	13'-4"	13'-0" f	13'-0" f	12'-1"	10'-7" f	10'-7" f	10'-7" f
600PS125-26	12	27'-0" f	23'-6"	20'-6"	22'-1" f	20'-6"	17'-11"	19'-1" f	18'-7"	16'-3"	15'-7" f	15'-7" f	14'-3"
600PS125-26	16	23'-5" f	21'-4"	18'-7"	19'-1" f	18'-7"	16'-3"	16'-7" f	16'-7" f	14'-9"	13'-6" f	13'-6" f	12'-11"
600PS125-26	24	19'-1" f	18'-7"	16'-3"	15'-7" f	15'-7" f	14'-3"	13'-6" f	13'-6" f	12'-11"	11'-0" f	11'-0" f	11'-0" f
162PS125-30	12	11'-10"	9'-4"	8'-2"	10'-4" f	8'-2"	7'-2"	9'-0" f	7'-5"	6'-6"	7'-4" f	6'-6"	5'-8"
162PS125-30	16	10'-9"	8'-6"	7'-5"	9'-0" f	7'-5"	6'-6"	7'-9" f	6'-9"	5'-11"	6'-4" f	5'-11"	5'-2"
162PS125-30	24	9'-0" f	7'-5"	6'-6"	7'-4" f	6'-6"	5'-8"	6'-4" f	5'-11"	5'-2"	5'-2" f	4'-6"	4'-6"
250PS125-30	12	16'-5"	13'-0"	11'-4"	13'-8" f	11'-4"	9'-11"	11'-10" f	10'-4"	9'-0"	9'-8" f	9'-0"	7'-11"
250PS125-30	16	14'-6" f	11'-10"	10'-4"	11'-10" f	10'-4"	9'-0"	10'-3" f	9'-5"	8'-4" f	8'-4" f	8'-2"	7'-2"
250PS125-30	24	11'-10" f	10'-4"	9'-0"	9'-8" f	9'-0"	7'-11"	8'-4" f	8'-2"	7'-2"	6'-10" f	6'-10" f	6'-3"
350PS125-30	12	19'-11" f	16'-8"	14'-7"	16'-3" f	14'-7"	12'-9"	14'-1" f	13'-3"	11'-7"	11'-6" f	11'-6" f	10'-1"
350PS125-30	16	17'-3" f	15'-2"	13'-3"	14'-1" f	13'-3"	11'-7"	12'-3" f	12'-1"	10'-7"	10'-0" f	10'-0" f	9'-2"
350PS125-30	24	14'-1" f	13'-3"	11'-7"	11'-6" f	11'-6" f	10'-1"	10'-0" f	10'-0" f	9'-2"	8'-2" f	8'-2" f	8'-0"
362PS125-30	12	20'-4" f	17'-2"	15'-0"	16'-7" f	15'-0"	13'-1"	14'-5" f	13'-7"	11'-11"	11'-9" f	11'-9" f	10'-5"
362PS125-30	16	17'-8" f	15'-7"	13'-7"	14'-5" f	13'-7"	11'-11"	12'-6" f	12'-5"	10'-10"	10'-2" f	10'-2" f	9'-5"
362PS125-30	24	14'-5" f	13'-7"	11'-11"	11'-9" f	11'-9" f	10'-5"	10'-2" f	10'-2" f	9'-5"	8'-4" f	8'-4" f	8'-3"
400PS125-30	12	21'-6" f	18'-6"	16'-2"	17'-7" f	16'-2"	14'-8"	15'-3" f	14'-8"	12'-10"	12'-5" f	12'-5" f	11'-3"
400PS125-30	16	18'-8" f	16'-10"	14'-8"	15'-3" f	14'-8"	12'-10"	13'-2" f	13'-2" f	11'-8"	10'-9" f	10'-9" f	10'-2"
400PS125-30	24	15'-3" f	14'-8"	12'-10"	12'-5" f	12'-5" f	11'-3"	10'-9" f	10'-9" f	10'-2"	8'-9" f	8'-9" f	8'-9" f
550PS125-30	12	26'-8" f	23'-11"	20'-11"	21'-9" f	20'-11"	18'-3"	18'-10" f	18'-10" f	16'-7"	15'-5" f	15'-5" f	14'-6"
550PS125-30	16	23'-1" f	21'-9"	19'-0"	18'-10" f	18'-10" f	16'-7"	16'-4" f	16'-4" f	15'-1"	13'-4" f	13'-4" f	13'-2"
550PS125-30	24	18'-10" f	18'-10" f	16'-7"	15'-5" f	15'-5" f	14'-6"	13'-4" f	13'-4" f	13'-2"	9'-1" (10'-11" f)	9'-1" (10'-11" f)	9'-1" (10'-11" f)
600PS125-30	12	27'-11" f	25'-7"	22'-4"	22'-10" f	22'-4"	19'-7"	19'-9" f	19'-9" f	17'-9"	16'-2" f	16'-2" f	15'-6"
600PS125-30	16	24'-2" f	23'-3"	20'-4"	19'-9" f	19'-9" f	17'-9"	17'-1" f	17'-1" f	16'-2"	13'-4" (14'-0" f)	13'-4" (14'-0" f)	13'-4" (14'-0" f)
600PS125-30	24	19'-9" f	19'-9" f	17'-9"	16'-2" f	16'-2" f	15'-6"	13'-4" (14'-0" f)	13'-4" (14'-0" f)	13'-4" (14'-0" f)	8'-11" (11'-5" f)	8'-11" (11'-5" f)	8'-11" (11'-5" f)
162PS125-33	12	12'-2"	9'-8"	8'-5"	10'-8"	8'-5"	7'-5"	9'-7" f	7'-8"	6'-8"	7'-10" f	6'-8"	5'-10"
162PS125-33	16	11'-1"	8'-9"	7'-8"	9'-7" f	7'-8"	6'-8"	8'-3" f	7'-0"	6'-1"	6'-9" f	6'-1"	5'-4"
162PS125-33	24	9'-7" f	7'-8"	6'-8"	7'-10" f	6'-8"	5'-10"	6'-9" f	6'-1"	5'-4"	5'-6" f	5'-4"	4'-8"
250PS125-33	12	16'-11"	13'-5"	11'-9"	14'-6" f	11'-9"	10'-3"	12'-7" f	10'-8"	9'-4"	10'-3" f	9'-4"	8'-2"
250PS125-33	16	15'-4" f	12'-3"	10'-8"	12'-7" f	10'-8"	9'-4"	10'-10" f	9'-8"	8'-6"	8'-10" f	8'-6"	7'-5"
250PS125-33	24	12'-7" f	10'-8"	9'-4"	10'-3" f	9'-4"	8'-2"	8'-10" f	8'-6"	7'-3"	7'-3" f	6'-6"	6'-6"
350PS125-33	12	21'-3" f	17'-3"	15'-1"	17'-4" f	15'-1"	13'-2"	15'-0" f	13'-8"	12'-0"	12'-3" f	12'-0"	10'-6"
350PS125-33	16	18'-5" f	15'-8"	13'-8"	15'-0" f	13'-8"	12'-0"	13'-0" f	12'-5"	10'-11"	10'-8" f	10'-8" f	9'-6"
350PS125-33	24	15'-0" f	13'-8"	12'-0"	12'-3" f	12'-0"	10'-6"	10'-8" f	10'-8" f	9'-6"	8'-8" f	8'-8" f	8'-4"
362PS125-33	12	21'-8" f	17'-9"	15'-6"	17'-9" f	15'-6"	13'-7"	15'-4" f	14'-1"	12'-4"	12'-6" f	12'-4"	10'-9"
362PS125-33	16	18'-9" f	16'-2"	14'-1"	15'-4" f	14'-1"	12'-4"	13'-3" f	12'-10"	11'-2"	10'-10" f	10'-10" f	9'-9"
362PS125-33	24	15'-4" f	14'-1"	12'-4"	12'-6" f	12'-4"	10'-9"	10'-10" f	10'-10" f	9'-9"	8'-10" f	8'-10" f	8'-6"
400PS125-33	12	23'-0" f	19'-2"	16'-9"	18'-9" f	16'-9"	14'-8"	16'-3" f	15'-3"	13'-3"	13'-3" f	13'-3" f	11'-7"
400PS125-33	16	19'-11" f	17'-5"	15'-3"	16'-3" f	15'-3"	13'-3"	14'-1" f	13'-10"	12'-1"	11'-6" f	11'-6" f	10'-7"
400PS125-33	24	16'-3" f	15'-3"	13'-3"	13'-3" f	13'-3" f	11'-7"	11'-6" f	11'-6" f	10'-7"	9'-4" f	9'-4" f	9'-3"
550PS125-33	12	28'-6" f	24'-10"	21'-8"	23'-3" f	21'-8"	18'-11"	20'-2" f	19'-8"	17'-3"	16'-6" f	16'-6" f	15'-0"
550PS125-33	16	24'-8" f	22'-7"	19'-8"	20'-2" f	19'-8"	17'-3"	17'-5" f	17'-5" f	15'-8"	14'-3" f	14'-3" f	13'-8"
550PS125-33	24	20'-2" f	19'-8"	17'-3"	16'-6" f	16'-6" f	15'-0"	14'-3" f	14'-3" f	13'-8"	11'-1" (11'-8" f)	11'-1" (11'-8" f)	11'-1" (11'-8" f)
600PS125-33	12	29'-10" f	26'-7"	23'-2"	24'-5" f	23'-2"	20'-3"	21'-1" f	21'-1" f	18'-3"	17'-3" f	17'-3" f	16'-1"
600PS125-33	16	25'-10" f	24'-1"	21'-1"	21'-1" f	21'-1" f	18'-5"	18'-3" f	18'-3" f	16'-9"	14'-11" f	14'-11" f	14'-7"
600PS125-33	24	21'-1" f	21'-1" f	18'-5"	17'-3" f	17'-3" f	16'-1"	14'-11" f	14'-11" f	14'-7"	10'-11" (12'-2" f)	10'-11" (12'-2" f)	10'-11" (12'-2" f)